

CITY COMMISSION MEETING VALLEY CITY, NORTH DAKOTA

Tuesday, December 02, 2025
5:00 PM

The City Commission Meeting will begin on Tuesday, December 02, 2025 at 5:00 PM CT, at the City Commission Chambers, 220 3rd St. NE, Valley City, ND.

The meeting is also available to view online <https://us06web.zoom.us/j/83961165836> or listen by calling (1 346 248 7799) Webinar ID: 839 6116 5836.

Board of City Commissioners	Role	Department Supervisor	Role
Dave Carlsrud	President	Gwen Crawford	City Administrator
Michael Bishop	Commissioner	Carl Martineck	City Attorney
Duane Magnuson	Commissioner	Brenda Klein	Finance Director
Jeffrey Erickson	Commissioner	Brandy Johnson	Deputy Auditor
Dick Gulmon	Commissioner	Tina Drabus	City Assessor
		Scott Magnuson	Fire Chief
		Nick Horner	Police Chief
		KLJ/Moore	City Engineers

NEXT RESOLUTION NO. 2507

NEXT ORDINANCE NO. 1185

CALL TO ORDER

ROLL CALL

PLEDGE OF ALLEGIANCE (PLEASE STAND)

APPROVAL OF AGENDA (ROLL CALL VOTE NEEDED WHEN CHANGES MADE TO THE AGENDA)

Roll Call: Erickson Gulmon Bishop Magnuson Carlsrud

APPROVAL OF CONSENT AGENDA

- | | |
|--|-----------------|
| A. Approve Minutes from the November 18, 2025 Finance Meeting and Commission Meeting | Page 3-6 |
| B. Approve Contractors License | Page 7-9 |
| a. Precision Concrete Cutters INC | |
| C. Approve Tree Trimming and Removal License | Page 10 |
| a. Ross' Tree Service | Page 11 |
| b. Ground to Sky | Page 12 |
| D. Approve Local Permit | Page 13 |
| a. Raffle - VCSU Trap Club | |
| b. Raffle Board – Laine Schwehr Road to Recovery Benefit | |

Roll Call: Gulmon Bishop Magnuson Erickson Carlsrud

PUBLIC COMMENTS

This portion of the meeting provides a limited public forum for Valley City residents, property owners and business owners to address the Board of City Commissioners on topics related to City business. Interested persons must submit a comment card with the individual's name, address, and the topic to be commented upon. Non-residents must provide the address of the City of Valley City business the individual operates or works at or the address of real property which the individual owns within the City of Valley City. Comments cards must be provided to the meeting secretary and approved prior to speaking. Public comments are limited solely to business matters and concerns pertinent to the City.

The following rules apply to Public Comments:

- Limited to five minutes per speaker.
- Must not interfere with the orderly conduct of the meeting.
- Must not be defamatory, abusive, harassing, or unlawful.
- May be prohibited if an alternative procedure exists to bring that particular type of public comment before the City, the public comment includes confidential or exempt information, or the public comment is otherwise prohibited by law.

Submission of written comments: In lieu of speaking, a written comment may be delivered to the meeting secretary prior to the start of the meeting. Written comments are limited to two pages. Any member of the public seeking to comment without attending in person may submit written comments to tpcity@valleycity.us. Written comments hand delivered at the time of the meeting or emailed prior to 4:00 pm on the date of the meeting will be distributed to the Board for their information and maintained in City files. Written comments are not read aloud at the meeting

ORDINANCE

1. Second and Final Reading of Ordinance 1181 to Rezone and Amend Zoning Map Lots 1-16, Block 22, Root's Addition, City of Valley City. *(City Attorney Martineck)*

Roll Call: Bishop Magnuson Erickson Gulmon Carlsrud

- 2. Second and Final Reading of Ordinance 1182 to Rezone and Amend Zoning Map Auditor’s Lot 1 and the S360’ of the E820’ of Auditor’s Lot 2 Both of the NW ¼ of Section 32-140N-58W, Barnes County. (City Attorney Martineck) **Page 18-47**

Roll Call: Magnuson Erickson Gulmon Bishop Carlsrud

- 3. First Reading of Ordinance 1183 To Amend and Reenact Sections 7-01-01 and 7-01-06 of the Valley City Municipal Code Related to Building Permits. (City Attorney Martineck) **Page 48**

Roll Call: Erickson Gulmon Bishop Magnuson Carlsrud

- 4. First Reading of Ordinance 1184 to amend and reenact sections 10-01-03 and subsection 2 of section 10-05-02 of the Valley City Municipal Code related to stormwater permits. (City Attorney Martineck) **Page 49-50**

Roll Call: Gulmon Bishop Magnuson Erickson Carlsrud

NEW BUSINESS

NB1. Set 2026 Commission Meeting Dates, Planning and Zoning Meetings, and Tax Equalization Meeting (City Administrator Crawford) **Page 51**

Roll Call: Bishop Magnuson Erickson Gulmon Carlsrud

NB2. Approve Amendment No. 1 to Firm Electric Service Contract (No. 14-UGPR-1004) with Western Area Power Administration (City Attorney Martineck) **Page 52-72**

Roll Call: Magnuson Erickson Gulmon Bishop Carlsrud

NB3. Approve Renewable Energy Certificate (REC) Designated Entity Contract (No. 25-UGPR-95) with Missouri River Energy Services and Western Area Power Administration (City Attorney Martineck) **Page 73-111**

Roll Call: Erickson Gulmon Bishop Magnuson Carlsrud

NB4. Approve Public Assistance Grant Program Subgrant Agreement for FEMA-4888-DR and Designate Finance Director Klein as the Primary Agent and City Administrator Crawford as the Alternate Agent (Finance Director Klein) **Page 112-133**

Roll Call: Gulmon Bishop Magnuson Erickson Carlsrud

NB5. Approve Task Order for Preliminary & Design Engineering for 2026 Pavement Improvement Project (Various Locations). (City Engineer) **Page 134-139**

Roll Call: Bishop Magnuson Erickson Gulmon Carlsrud

NB6. Approve IJJA Grid Resilience Grant (City Administrator Crawford)

Roll Call: Magnuson Erickson Gulmon Bishop Carlsrud **Page 140-147**

CITY ADMINISTRATOR’S REPORT

CITY UPDATES & COMMISSION REPORTS

ADJOURN

CITY COMMISSION FINANCE MEETING VALLEY CITY, NORTH DAKOTA

Tuesday, November 18, 2025 2:30 PM

Called to Order

President Carlsrud called the meeting to order at 2:30 PM.

Roll Call

Members present: President Carlsrud, Commissioner Bishop, Commissioner Magnuson, Commissioner Erickson, Commissioner Gulmon.

Other present: City Administrator Crawford, City Attorney Martineck, Finance Director Klein, Police Chief Horner

Agenda Items

Review Monthly Bills/Reports

Finance Director Klein reported on Monthly Expenses totaling \$3,275,415.

Transportation Plan Update

Wade Kline with KLJ presented the draft report of the Subarea Transportation Plan that KLJ is developing in cooperation with the City and the North Dakota Department of Transportation. It focuses on the area south of I-94 between exits 292 and 294, where there is potential for future development. The study includes terrain analysis, low-lying areas, and existing roadway concepts.

Extensive public engagement has been conducted, including one-on-one meetings with key property owners. More public input is planned for December. Final Presentation Planned for January 2026.

Discuss SIRN Tower Conditional Use Permit

Rob Viera with Allo Towers discussed Building a statewide system for first responders. Initially, Joel Quanbeck recommended moving the tower east, as suggested by Rob, due to safety concerns. However, after reviewing engineering documentation, Joel now believes the tower's current proposed location is safe and would not fully impact County Road 19 if it collapsed. As a result, the condition requiring the tower to be 225 feet East of County Road 19 can be removed.

The remaining conditions for approval are:

FAA approval of the tower and its height.

No objections from the Barnes County Municipal Airport Manager.

The property must be rezoned to Agricultural District (on the agenda for tonight).

A copy of the resolution is in the finance meeting packet and will be approved at the next commission meeting.

Discuss Previous Authorization of Bids for Cropland Lease – Auditor's Lot 2 NE1/4 31-140-58 and Auditor's Lot 1 NW1/4 32-140-58

The City Commission had previously approved going out for bids on the cropland near the Lagoon property. However, after reviewing the contract, it was found that a one-year extension is allowed if both parties agree. The current tenant, had already prepared the land for spring planting under the assumption that the contract would be extended. After discussing the situation, city staff decided it would be appropriate to move forward with a one-year extension and delay bidding until next year. The current tenant has been informed that he should not do any further work unless he is awarded the bid in the future. As a result, the Commission will be asked to rescind the previous resolution to seek bids.

Additionally, the city recognized the need to move up the bidding timeline in future years, likely to late summer, to give potential tenants enough time to prepare the land in the fall. This approach is considered appropriate under the circumstances and remains within the terms of the original agreement.

Discuss NDDOT Special Road Fund

The Special Road Fund (SRF) Program is a funding initiative by the Department of Transportation designed to support roads that provide access to or are located within recreational areas. The program has

recently improved its funding structure, increasing the cost share from 60-40 to 80-20 and raising the maximum funding amount from \$300,000 to \$500,000.

The proposed project involves 14th Street Southwest, which serves as the primary access road to Bjornson Golf Course. This road, now under city jurisdiction, was previously maintained by Barnes County, which used SRF funds in 2001 for an overlay project.

2026 MRES REC Election Form

REC Allocations were discussed and decided to sell all available REC Allocations

Department Reports

Sanitation Department

Sanitation Supervisor Swart – Reviewed Residential Container Count

Water Department

Water Superintendent Hesch – Update on summertime running to turn wells back on until temps are back up

Electric Department

Electrical Superintendent Senf - Reported on outages and AI Facilities and how we are not equipped to handle these kinds of load demands.

Fire Department

Fire Chief Magnuson – Reported on calls and pages.

Police Department

Police Chief Horner – Updated on training, interviews for open positions, and testing axon application

Street Department

Operations Supervisor Klemisch – Reported on water leak and needing to hire out for repair. Discussed completed and upcoming projects

Administration

City Administrator Crawford – Discussed starting life insurance at 90 days instead of the 180 days.

Adjourn

The meeting was adjourned at 4:42 PM.

**CITY COMMISSION MEETING
VALLEY CITY, NORTH DAKOTA**

Tuesday, November 18, 2025

President Carlsrud called the meeting to order at 5:00 PM.

Members present: President Carlsrud, Commissioner Erickson, Commissioner Gulmon, Commissioner Magnuson, Commissioner Bishop

Others: City Administrator Crawford, City Attorney Martineck, Finance Director Klein, Police Chief Horner

PLEDGE OF ALLEGIANCE

APPROVAL OF AGENDA

Change Wording on New Business No.5 to Approve Selling All Available 2026 REC Allocations

Commissioner Bishop Motioned to Approve, Seconded by Commissioner Magnuson.

Roll Call: Bishop-Yes; Magnuson-Yes; Erickson-Yes; Gulmon-Yes; Carlsrud-Yes Motion passed

APPROVAL OF CONSENT AGENDA

A. Approve Minutes from the November 04, 2025 (Finance Director Klein)

B. Approve Local Contractors License

a. Freeman Trades

C. Approve Application for Local Permit (Raffle)

a. VCSU Student Chapter of the Wildlife Society

b. S.H.I.N.E Dance Team

Commissioner Erickson Motioned to Approve, Seconded by Commissioner Bishop

Roll Call: Bishop-Yes; Magnuson-Yes; Erickson-Yes; Gulmon-Yes; Carlsrud-Yes Motion passed

PUBLIC HEARING

1. Open Public Hearing Regarding Ordinance 1181 to Rezone and Amend Zoning Map Lots 1-16, Block 22, Root's Addition, City of Valley City.

No Public Comments.

Motion to Close Hearing by Commissioner Magnuson, Seconded by Commissioner Gulmon.

Roll Call: Magnuson-Yes; Erickson-Yes; Gulmon-Yes; Bishop-Yes; Carlsrud-Yes Motion Passed

Approve First Reading of Ordinance 1181 to Rezone and Amend Zoning Map Lots 1-16, Block 22, Root's Addition, City of Valley City.

Motion to Approve by Commissioner Bishop, Seconded by Commissioner Magnuson.

Roll Call: Erickson-Yes; Gulmon-Yes; Bishop-Yes; Magnuson-Yes; Carlsrud-Yes Motion Passed

2. Open Public Hearing Regarding First Reading of Ordinance 1182 to Rezone and Amend Zoning Map Auditor's Lot 1 and the S360' of the E820' of Auditor's Lot 2 Both of the NW ¼ of Section 32-140N-58W, Barnes County.

No Public Comments.

Motion to Close Hearing by Commissioner Magnuson, Seconded by Commissioner Gulmon.

Roll Call: Gulmon-Yes; Bishop-Yes; Magnuson-Yes; Erickson-Yes; Carlsrud-Yes Motion Passed

Approve First Reading of Ordinance 1182 to Rezone and Amend Zoning Map Auditor's Lot 1 and the S360' of the E820' of Auditor's Lot 2 Both of the NW ¼ of Section 32-140N-58W, Barnes County.

Motion to Approve by Commissioner Bishop, Seconded by Commissioner Magnuson.

Roll Call: Bishop-Yes; Magnuson-Yes; Erickson-Yes; Gulmon-Yes; Carlsrud-Yes Motion Passed

3. Open Public Hearing Regarding Liquor License Application for Sho3 LLC dba Econo Lodge.

Tina Babler (Sho3 LLC Manager) was Present and Stated She Can Answer Any Questions.

No Questions or Comments.

Motion to Close Hearing by Commissioner Gulmon, Seconded by Commissioner Bishop.

Roll Call: Magnuson-Yes; Erickson-Yes; Gulmon-Yes; Bishop-Yes; Carlsrud-Yes Motion Passed

Approve Application for Alcoholic Beverage License Application for Sho3 LLC dba Econo Lodge.

Motion to Approve by Commissioner Bishop, Seconded by Commissioner Gulmon.

Roll Call: Erickson-Yes; Gulmon-Yes; Bishop-Yes; Magnuson-Yes; Carlsrud-Yes Motion Passed

RESOLUTION

Resolution No 2505 a Resolution Approving Conditional Use Permit Auditors Lot 1 and the S 360' of the E 820' of Auditor's Lot 2 NW¼ Section 32-140-58.

Motion to Approve by Commissioner Magnuson, Seconded by Commissioner Erickson.

Roll Call: Gulmon-Yes; Bishop-Yes; Magnuson-Yes; Erickson-Yes; Carlsrud-Yes Motion Passed

NEW BUSINESS

NB1. Approve Monthly Bills for the City and Public Works in the Amount of \$3,275,415

Motion to Approve by Commissioner Gulmon, Seconded by Commissioner Bishop.

Roll Call: Bishop-Yes; Magnuson-Yes; Erickson-Yes; Gulmon-Yes; Carlsrud-Yes Motion Passed

NB2. Approve Employee Assistance Program Contract Renewal – The Village

Motion to Approve by Commissioner Gulmon, Seconded by Commissioner Bishop.

Roll Call: Magnuson-Yes; Erickson-Yes; Gulmon-Yes; Bishop-Yes; Carlsrud-Yes Motion Passed

NB3. Rescind Approval of Resolution 2503, A Resolution Authorizing Bids for Cropland Lease – Auditor’s Lot 2 NE1/4 31-140-58 and Auditor’s Lot 1 NW1/4 32-140-58

Motion to Approve by Commissioner Magnuson, Seconded by Commissioner Gulmon.

Roll Call: Erickson-Yes; Gulmon-Yes; Bishop-Yes; Magnuson-Yes; Carlsrud-Yes Motion Passed

NB4. Approve Addendum to Farm Lease for One Year Pursuant to Contract Dated April 18, 2024 -- Auditor’s Lot 2 NE1/4 31-140-58 and Auditor’s Lot 1 NW1/4 32-140-58

Motion to Approve by Commissioner Bishop, Seconded by Commissioner Magnuson.

Roll Call: Gulmon-Yes; Bishop-Yes; Magnuson-Yes; Erickson-Yes; Carlsrud-Yes Motion Passed

NB5. Approve Selling All Available 2026 REC Allocations.

Motion to Approve by Commissioner Bishop, Seconded by Commissioner Magnuson.

Roll Call: Gulmon-Yes; Bishop-Yes; Magnuson-Yes; Erickson-Yes; Carlsrud-Yes Motion Passed

CITY ADMINISTRATOR’S REPORT

City Administrator Crawford Reported on the New Service Center, Underground Utilities and Masonry Work Have Begun. Crews are Working Around Weather Conditions to Maintain Progress.

CITY UPDATES & COMMISSION REPORTS

Finance Director Klein Noted the State Water Commission Preliminary Meeting is Scheduled for Thursday and the City is Seeking Funding for Water Tower Removal and Other Infrastructure.

Commissioner Gulmon Reported the Budget is Tracking Well, With Revenues Exceeding Expenses and Reserves Within Plan.

President Carlsrud Reminded Residents to Enjoy the Upcoming Light Parade and Thanked City Staff for Their Work on Holiday Decorations and Storm Cleanup.

ADJOURN

Meeting was adjourned at 5:21 P.M.

Attested to by:

Brenda Klein, Finance Director
City of Valley City

Dave Carlsrud, President of the
City of Valley City Commission

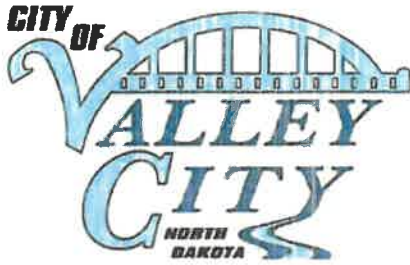

City of Valley City, North Dakota
Application for
Contractor, Electrician, Plumber and/or
Mechanical Contractor License(s)
FOR PERIOD: June 1, 2025 – May 31, 2026

The undersigned hereby makes application for a license to the City of Valley City, North Dakota, and agrees to comply with the requirements of City Ordinances pertaining thereto.

Name of Business: Precision Concrete Cutters, Inc
Owner: Terry Leabo
Mailing Address: 5002 19th Ave N, Ste A
City, State Zip Code: Fargo, ND 58102
Phone Number: 701-280-7038
Email Address: lacie@pccnd.com
Today's Date: 11/17/2025

Type of License Applying For (check all that apply):

Contractor Electrician Plumber Mechanical

State License Numbers (provide all that apply):

Electrician Plumber 41485 Contractor

Licenses will only be issued to master electricians (NDCC 43-09-20) and master plumbers (NDCC 43-18-10).

A copy of the following must be filed with the City Auditor as part of this application:

Certificate of Liability Insurance, City of Valley City as certificate holder

Current copy of State Electrician and/or Plumber License

Current copy of State Contractor License,

No person may engage in the business nor act in the capacity of a contractor within this city when the cost, value, or price per job exceeds the sum of \$1,000 without first having a license.

If applicant does not provide state contractor license and states that it is not required please sign here:

LICENSE FEE: _____ \$100 if initial application, make checks payable to City of Valley City
 _____ \$50 if renewal application

RETURN TO: Valley City Auditor
 220 3rd St. NE
 Valley City, ND 58072

Phone: (701) 845 – 1700
Email: tplecity@valleycity.us

State of North Dakota

SECRETARY OF STATE



CONTRACTOR LICENSE

NO: 000041485

CLASS: A

The undersigned, as Secretary of State of the state of North Dakota and Registrar of Contractors, certifies that **PRECISION CONCRETE CUTTERS, INC.** whose address is in FARGO, ND, has filed in this office proper documents for a Contractor License valid until March 1, 2026, and has complied with all requirements of North Dakota Century Code, chapter 43-07.

PRECISION CONCRETE CUTTERS, INC. is entitled to bid on and accept contracts as authorized by law under this license without limit as to the value of any single contract project.

Dated: January 16, 2025

A handwritten signature in black ink that reads "Michael Howe".

Michael Howe
Secretary of State

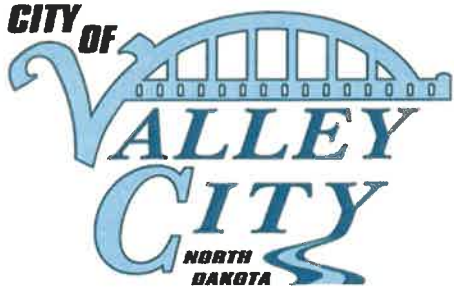

City of Valley City, North Dakota
Application for
Tree Trimming and Removal Service
License

FOR PERIOD: January 1, 2026 - December 31, 2026

The undersigned hereby makes application for a license to the City of Valley City, North Dakota, and agrees to comply with the requirements of City Ordinances pertaining thereto.

Name of Business: Ross' Tree Service
Owner: Dean & Deb Ross
Mailing Address: 925 Hanna Avenue
City, State Zip Code: Valley City ND 58072
Phone Number: 840-2464 or 845-4621
Email Address: dross1600@yahoo.com
Today's Date: 11-20-25

All applicants shall file with the City Auditor by December 10th as part of this application:

_____ Certificate of Liability Insurance
LICENSE FEE: _____ \$100 if initial application, make checks payable to City of Valley City
 X \$50 if renewal application
RETURN TO: Valley City Auditor Pd 11.20.25
 220 3rd St. NE Ct # 14825
 Valley City, ND 58072
 Phone: (701) 845 - 1700

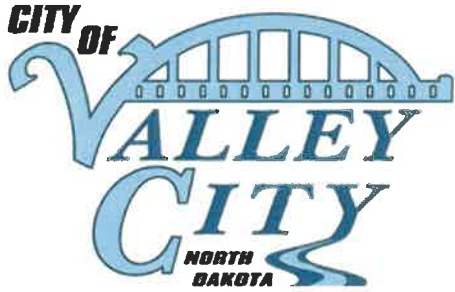

**City of Valley City, North Dakota
Application for
Tree Trimming and Removal Service
License**

FOR PERIOD: January 1, 2026 - December 31, 2026

The undersigned hereby makes application for a license to the City of Valley City, North Dakota, and agrees to comply with the requirements of City Ordinances pertaining thereto.

Name of Business: Ground to Sky Tree Service

Owner: Bryan Edwards, Aaron Bulow, Will Hansen

Mailing Address: 11088 33rd St SE

City, State Zip Code: Valley City ND 58072

Phone Number: 701-840-7572

Email Address: acbvalley@gmail.com

Today's Date: 11/19/25

All applicants shall file with the City Auditor by December 10th as part of this application:

	<input type="checkbox"/> Certificate of Liability Insurance	<i>Insure Forward will send current certificate</i>
LICENSE FEE:	<input type="checkbox"/> \$100 if initial application , make checks payable to City of Valley City	
	<input checked="" type="checkbox"/> \$50 if renewal application	
RETURN TO:	Valley City Auditor 220 3 rd St. NE Valley City, ND 58072 Phone: (701) 845 – 1700	<i>Pd 11.25.2025 ck # 1381</i>



APPLICATION FOR A LOCAL PERMIT OR RESTRICTED EVENT PERMIT

NORTH DAKOTA OFFICE OF ATTORNEY GENERAL
GAMING DIVISION
SFN 9338 (9-2023)

Ad #10
Cash 11.24.2025

Applying for (check one)

Local Permit Restricted Event Permit*

Games to be conducted

Bingo Raffle Raffle Board Calendar Raffle Sports Pool Poker* Twenty-One* Paddlewheels*

*See Instruction 2 (f) on Page 2. Poker, Twenty-One, and Paddlewheels may be conducted Only with a Restricted Event Permit. Only one permit per year.
LOCAL PERMIT RAFFLES MAY NOT BE CONDUCTED ONLINE AND CREDIT CARDS MAY NOT BE USED FOR WAGERS

ORGANIZATION INFO

Name of Organization or Group VCSU Trap Club		Dates of Activity (Does not include dates for the sales of tickets) April 30, 2026	
Organization or Group Contact Person Kasey Odegaard		E-mail Kasey.Odegaard@ndus.edu	Telephone Number (701) 641-8702
Business Address 230 Viking Dr. SW Box 54		City Valley City	State ND
Mailing Address (if different)		City	State ND
			ZIP Code 58072

SITE INFO

Site Name Valley City State University		County Barnes	
Site Physical Address 230 Viking Dr. SW		City Valley City	State ND
			ZIP Code 58072
Provide the exact date(s) & frequency of each event & type (Ex. Bingo every Friday 10/1-12/31, Raffle - 10/30, 11/30, 12/31, etc.) Raffle Drawing - April 30, 2026			

PRIZE / AWARD INFO (If More Prizes, Attach An Additional Sheet)

Game Type	Description of Prize	Exact Retail Value of Prize
Raffle	Stoeyer M3000 12-Gauge Semi-auto 28 in barrel <small>Black finish</small>	\$ 599.99
Raffle	4 \$ 100 visa gift cards	\$ 400
Total (limit \$40,000 per year)		\$ 999.99

ADDITIONAL REQUIRED INFORMATION

Intended Uses of Gaming Proceeds
Fundraiser for the VCSU Trap Shooting Club

Does the organization presently have a state gaming license? (If yes, the organization is not eligible for a local permit or restricted event permit and should call the Office of Attorney General at 1-800-326-9240)

Yes No

Has the organization or group received a restricted event permit from any city or county for the fiscal year July 1 - June 30 (If yes, the organization or group does not qualify for a local permit or restricted event permit)

Yes No

Has the organization or group received a local permit from an city or county for the fiscal year July 1 - June 30 (If yes, indicate the total retail value of all prizes previously awarded)

No Yes - Total Retail Value: _____ (This amount is part of the total prize limit for \$40,000 per fiscal year)

Is the organization or group a state political party or legislative district party? (If yes, the organization or group may only conduct a raffle and must complete SFN 52880 "Report on a Restricted Event Permit" within 30 days of the event. Net proceeds may be for political purposes.)

Yes No

Printed Name of Organization Group's Permit Organizer Kasey Odegaard	Telephone Number (701) 641-8702	E-mail Address Kasey.Odegaard@ndus.edu
Signature of Organization Group's Permit Organizer <i>Kasey Odegaard</i>	Title President	Date 11/24/25



APPLICATION FOR A LOCAL PERMIT OR RESTRICTED EVENT PERMIT

NORTH DAKOTA OFFICE OF ATTORNEY GENERAL

GAMING DIVISION

SFN 9338 (8-2025)

Applying for (check one)

Local Permit Restricted Event Permit*

Games to be conducted Raffle by a Political or Legislative District Party

Bingo Raffle Raffle Board Calendar Raffle Sports Pool Poker* Twenty-One* Paddlewheels*

*See Instruction 2 (f) on Page 2. Poker, Twenty-One, and Paddlewheels may be conducted Only with a Restricted Event Permit. Only one permit per year.

LOCAL PERMIT RAFFLES MAY NOT BE CONDUCTED ONLINE AND CREDIT CARDS MAY NOT BE USED FOR WAGERS

ORGANIZATION INFO

Name of Organization or Group <i>Laine Schwehr Road to Recovery Benefit</i>		Dates of Activity (Does not include dates for the sales of tickets) <i>January 3, 2026</i>	
Organization or Group Contact Person <i>Janet Gierke</i>	E-mail <i>janet.gierke@gmail.com</i>	Telephone Number <i>701-490-0991</i>	
Business Address	City	State	ZIP Code
	<i>Valley City</i>	<i>ND</i>	<i>58072</i>
Mailing Address (if different) <i>419 8th Ave SW</i>	City <i>Valley City</i>	State <i>ND</i>	ZIP Code <i>58072</i>

SITE INFO

Site Name <i>Valley City Eagles Club</i>	County <i>Barnes</i>		
Site Physical Address <i>345 12th Ave NE</i>	City <i>Valley City</i>	State <i>ND</i>	ZIP Code <i>58072</i>
Provide the exact date(s) & frequency of each event & type (Ex. Bingo every Friday 10/1-12/31, Raffle - 10/30, 11/30, 12/31, etc.)			

PRIZE / AWARD INFO (If More Prizes, Attach An Additional Sheet)

Game Type	Description of Prize	Exact Retail Value of Prize
<i>Raffle Board</i>	<i>4 to 5 boards</i>	<i>1000⁰⁰</i>
Total (limit \$50,000 per year)		<i>\$ 1000⁰⁰</i>

ADDITIONAL REQUIRED INFORMATION

Intended Uses of Gaming Proceeds <i>Donation to Laine Schwehr</i>
Does the organization presently have a state gaming license? (If yes, the organization is not eligible for a local permit or restricted event permit and should call the Office of Attorney General at 1-800-326-9240) <input type="checkbox"/> Yes <input checked="" type="checkbox"/> No
Has the organization or group received a restricted event permit from any city or county for the fiscal year July 1 - June 30 (If yes, the organization or group does not qualify for a local permit or restricted event permit) <input type="checkbox"/> Yes <input checked="" type="checkbox"/> No
Has the organization or group received a local permit from an city or county for the fiscal year July 1 - June 30 (If yes, indicate the total retail value of all prizes previously awarded) <input checked="" type="checkbox"/> No <input type="checkbox"/> Yes - Total Retail Value: _____ (This amount is part of the total prize limit for \$50,000 per fiscal year)
Is the organization or group a state political party or legislative district party? (If yes, the organization or group may only conduct a raffle and must complete SFN 52880 "Report on a Restricted Event Permit" within 30 days of the event. Net proceeds may be for political purposes.) <input type="checkbox"/> Yes <input checked="" type="checkbox"/> No

Printed Name of Organization Group's Permit Organizer <i>Janet Gierke</i>	Telephone Number <i>701-490-0991</i>	E-mail Address <i>janet.gierke@gmail.com</i>
Signature of Organization Group's Permit Organizer <i>Janet Gierke</i>	Title	Date <i>11/25/25</i>

ORDINANCE NO. 1181

ORDINANCE TO REZONE AND AMEND ZONING MAP LOTS 1-16, BLOCK 22, ROOT'S ADDITION, CITY OF VALLEY CITY

WHEREAS, an application was submitted to the Valley City Planning and Zoning Commission requesting approval to rezone Lots 1-16, Block 22, Root's Addition to Valley City, North Dakota, from Open Space District to R-4 Multi-Family Residential District for the purpose of school facilities and athletic fields; and

WHEREAS, the Planning and Zoning Commission, following a public hearing on October 14, 2025, approved the rezone to R-4 Multi-Family Residential District with no conditions; and

WHEREAS, Board of City Commissioners held a public hearing and received comments on November 18, 2025; and

WHEREAS, the application meets the presentation requirements and applicable standards set forth in section 11-07-06 of the Valley City Municipal Code; and

WHEREAS, the Board of City Commissioners considered the factors set forth in V.C.M.C. § 11-07-06, including the compatibility of the proposed use with the surrounding neighborhood, and conformity with the Valley City Comprehensive Land Use and Transportation Plan.

NOW, THEREFORE, BE IT ORDAINED BY THE BOARD OF CITY COMMISSIONERS OF THE CITY OF VALLEY CITY, BARNES COUNTY, NORTH DAKOTA:

Section 1. Lots 1-16, Block 22, Root's Addition to Valley City are re-zoned to R-4 Multi-Family Residential District.

Section 2. The Valley City Zoning Map shall be amended as set forth in V.C.M.C. § 11-03-01.

Section 3. All ordinances, or parts of ordinances, or provisions of the Valley City Municipal Code in conflict herewith, are hereby repealed.

Section 4. This ordinance shall take effect and be in full force from and after its second reading, final adoption and approval by the Board of City Commissioners.

Dave Carlsrud, President
Board of City Commissioners

ATTEST:

Brenda Klein, Finance Director

Introduction and First Reading: November 18, 2025
Second Reading, Final Passage, Adoption:

Valley City Planning and Zoning APPLICATION

Procedures and submission requirements can be found in the Valley City Municipal Code. Application and fees must be submitted as soon as possible in order to allow sufficient time for publication of required public hearing notices. The Planning and Zoning Commission generally meets and holds public hearings the 2nd Tuesday of every month at 4pm. Additional fees will be assessed if it is determined a meeting is needed to be held outside of regularly scheduled meeting dates.

Please check all that apply and submit payment with application. This application may be utilized for more than one request or applicant may copy and attach a separate application for each item as needed.

- | | |
|--|--|
| <input type="checkbox"/> Variance (\$100)
<input type="checkbox"/> Vacation of Street/Alley (\$150)
<input type="checkbox"/> Zoning Ordinance Text Amendment (\$200) | <input checked="" type="checkbox"/> Zoning Map Amendment (Zone/Rezone) (\$200)
<input type="checkbox"/> Conditional Use Permit (\$200)
<input type="checkbox"/> PUD/PUD Amendment (\$200)
<input type="checkbox"/> Other: _____ (\$TBD) |
|--|--|

Applicant Name: Valley City Public Schools Phone: 701-845-0483
Applicant Address: 460 Central Ave N
City, State, Zip: Valley City ND 58072 Email Address: josh.johnson@k12.nd.us

Owner Name: Valley City Public Schools Phone: 701-845-0483
Owner Address: 460 Central Ave N
City, State, Zip: Valley City ND 58072 Email Address: josh.johnson@k12.nd.us

Owner Authorization: _____ Date: _____
If the applicant is not the same as the owner, the owner must sign the application or submit a letter authorizing the applicant to proceed on behalf of the owner.

Physical Address of Property (if assigned): <u>N/A</u>
Property Description (attach add'l sheet if necessary): Parcel ID# <u>63-4271783</u> Lot <u>ALL</u> Block <u>22</u> Subdivision <u>Roots Addition</u> Section _____ Twp _____ Range _____ Metes and Bounds: _____ _____ _____
Briefly describe the reason for request: <u>Proposed plans for this land have required a zoning change per discussions with the City & VC.</u>

Applicant Signature:  Date: 9-29-25
 The signature of the applicant and owner (or written permission of the owner) certifies that permission is granted by the owner to all authorized City personnel to enter the property for the purpose of review of this application. The applicant and owner further certify that all City Ordinances will be complied with and that the information given within this application as well as the plans submitted are in all respects true and correct to the best of my knowledge and belief.

VALLEY CITY USE ONLY:

Application and fees. Rec'd on date: _____ in the amount of \$ _____ Cash/Check
 Application/Supporting documents deemed complete. Date: _____ Initials _____

P&Z: **Hearing Date** _____ Approval: Yes Yes with conditions No
Publication Dates:
P&Z findings and recommendations sent to City Commission. Date: _____

City Commission: **Hearing Date** _____ Approval: Yes Yes with conditions No
Publication Dates:

Valley City Planning Commission – October 14, 2025 Agenda

Action Request: Rezoning Application

Applicant: Josh Johnson, Valley City Public Schools

Objective: Change current zoning to allow public school facilities as a use on the site.

Property Owners: Valley City Public Schools

Legal Description: Lots 1-16 Block 22 of Root’s Addition to the City of Valley City, North Dakota, having an area of approximately 2.66 acres.

Project Location: The land proposed to be rezoned is located south of 9th Street NE and between 4th Avenue NE and 5th Avenue NE in Valley City. The map below shows the applicable parcel highlighted in blue.



Analysis: The land included in this proposed replat is zoned Open Space District and was previously owned by the City of Valley City. Ownership has been transferred to the Valley City School District in support of the development of new school facilities on an adjacent block. The intent of the Open Space District is conserve existing open space, to protect the flood plain, and to preserve natural growth in order to stabilize steep slopes, to assist aquifer recharge, to cool adjacent residential neighborhoods on hot summer days and to provide a wildlife habitat in close proximity to children. Permitted uses in the Open Space District are limited to farms, parks, playgrounds, golf courses, greenhouses, forest preserve and other public recreation space, and other uses of the same general character. In order to treat zoning for public school facilities consistently and more clearly allow for them, the land is proposed to be rezoned to R-4 Multi-Family Residential District which allows elementary schools, junior high schools, high schools as a permitted use. The R-4 District intent includes allowing certain compatible

nonresidential uses and allows for greater densities of development than in other residential districts. It should be noted that the future land use map identifies the future land use for this land as park and golf course. There is not a direct correlation between zoning districts and the future land use categories, but Table 6-2 of the Comprehensive Plan indicates that the R-4 District is compatible with this future land use category. The Comprehensive Plan indicates this land use category is intended for active and passive recreational needs of the community and is generally expected to be publicly owned.

The anticipated uses of this land are expected to include various sporting activities for the Valley City Public School District. No buildings are anticipated to be constructed at this time, but accessory buildings in support of the sporting activity usage may be constructed at a later time. It is reasonable to expect that there will occasionally be increased traffic and noise levels in the vicinity of this tract due to the changing land use.

Findings:

- A. The proposed zoning change to R-4 is consistent with the future land use plan.
- B. The proposed public school facility use is consistent with the proposed R-4 District requirements.
- C. It will be important for the School District and the City of Valley City to address potential traffic issues associated with the proposed new school facilities being planned for this neighborhood.

Recommendation:

Barring additional information presented prior to or at the October 2025 Planning and Zoning Commission, it is recommended the proposed zone change to R-4 be approved and recommended for approval to the Board of City Commissioners.

ORDINANCE NO. 1182

ORDINANCE TO REZONE AND AMEND ZONING MAP AUDITORS LOT 1 AND THE S360' OF THE E820' OF AUDITOR'S LOT 2 BOTH OF THE NW¼ OF SECTION 32-140N-58W, BARNES COUNTY

WHEREAS, an application was submitted to the Valley City Planning and Zoning Commission requesting approval to rezone Auditors Lot 1 and the S360' of the E820' of Auditor's Lot 2 both of the NW¼ of Section 32-140N-58W in Barnes County, North Dakota, to AG Agricultural District for the intended uses of cropland, a city lagoon, and a telecommunications tower; and

WHEREAS, the Planning and Zoning Commission, following a public hearing on October 14, 2025, approved the rezone to AG Agricultural District with no conditions; and

WHEREAS, Board of City Commissioners held a public hearing and received comments on November 18, 2025; and

WHEREAS, the application meets the presentation requirements and applicable standards set forth in section 11-07-06 of the Valley City Municipal Code; and

WHEREAS, the Board of City Commissioners considered the factors set forth in V.C.M.C. § 11-07-06, including the compatibility of the proposed use with the surrounding neighborhood, and conformity with the Valley City Comprehensive Land Use and Transportation Plan.

NOW, THEREFORE, BE IT ORDAINED BY THE BOARD OF CITY COMMISSIONERS OF THE CITY OF VALLEY CITY, BARNES COUNTY, NORTH DAKOTA:

Section 1. Auditors Lot 1 and the S360' of the E820' of Auditor's Lot 2 both of the NW¼ of Section 32-140N-58W in Barnes County, North Dakota, are re-zoned to AG Agricultural District.

Section 2. The Valley City Zoning Map shall be amended as set forth in V.C.M.C. § 11-03-01.

Section 3. All ordinances, or parts of ordinances, or provisions of the Valley City Municipal Code in conflict herewith, are hereby repealed.

Section 4. This ordinance shall take effect and be in full force from and after its second reading, final adoption and approval by the Board of City Commissioners.

Dave Carlsrud, President
Board of City Commissioners

ATTEST:

Brenda Klein, Finance Director

Introduction and First Reading: November 18, 2025
Second Reading, Final Passage, Adoption:

Valley City Planning and Zoning APPLICATION

Procedures and submission requirements can be found in the Valley City Municipal Code. Application and fees must be submitted as soon as possible in order to allow sufficient time for publication of required public hearing notices. The Planning and Zoning Commission generally meets and holds public hearings the 2nd Tuesday of every month at 4pm. Additional fees will be assessed if it is determined a meeting is needed to be held outside of regularly scheduled meeting dates.

Please check all that apply and submit payment with application. This application may be utilized for more than one request or applicant may copy and attach a separate application for each item as needed.

- | | |
|---|---|
| <input type="checkbox"/> Plat/Replat (\$150 + \$2 per lot) | <input type="checkbox"/> Zoning Map Amendment (Zone/Rezone) (\$200) |
| <input type="checkbox"/> Recording Fee (1- 49 lots - \$30 - 50+ lots \$60)* | <input checked="" type="checkbox"/> Conditional Use Permit (\$200) |
| <input type="checkbox"/> Variance (\$100) | <input type="checkbox"/> PUD/PUD Amendment (\$200) |
| <input type="checkbox"/> Vacation of Street/Alley (\$150) | <input type="checkbox"/> Other: _____ (\$TBD) |
| <input type="checkbox"/> Zoning Ordinance Text Amendment (\$200) | *Recording fee is refundable if plat/replat is denied |

Applicant Name: Alto Towers / STATE of North Dakota Phone: 612-801-2228
Applicant Address: 229 Byrondale Ave N
City, State, Zip: WAYZATA, MN 55391 Email Address: robertsviera@yahoo.com

Owner Name: City of Valley City Phone: 701-845-1700
Owner Address: 220 3rd ST NE
City, State, Zip: Valley City, ND 58072 Email Address: Joel.guanbeck@klseng.com

Owner Authorization: _____ **Date:** _____
If the applicant is not the same as the owner, the owner must sign the application or submit a letter authorizing the applicant to proceed on behalf of the owner.

Physical Address of Property (if assigned): _____

Property Description (attach add'l sheet if necessary):
Parcel ID# 413220200 **Lot** 1 **Block** _____ **Subdivision** _____
Section 32 **Twp** 140 **Range** 58 **Metes and Bounds:** Aud Lot 1 of NW 1/4 E 5360' of E 820' of Aud Lot 2 65.39 Acres

Briefly describe the reason for request: Alto Towers and The STATE of North Dakota are seeking permission build up to a 250' (255' w/ a 5' lightning rod) self-support, wireless communications tower for its first responder, state-wide network. The 250' tower will be located w/in a 60' x 60' parcel of property and contain a 30' wide access/utility easement as well as a separate 30' utility easement.

Applicant Signature: [Signature] **Date:** 10/7/25

The signature of the applicant and owner (or written permission of the owner) certifies that permission is granted by the owner to all authorized City personnel to enter the property for the purpose of review of this application. The applicant and owner further certify that all City Ordinances will be complied with and that the information given within this application as well as the plans submitted are in all respects true and correct to the best of my knowledge and belief.

VALLEY CITY USE ONLY:

Application and fees. Rec'd on date: _____ in the amount of \$ _____ Cash/Check
Application/Supporting documents deemed complete. Date: _____ Initials _____

P&Z: **Hearing Date** _____ **Approval:** Yes Yes with conditions No
Publication Dates: _____
P&Z findings and recommendations sent to City Commission. Date: _____

City Commission: **Hearing Date** _____ **Approval:** Yes Yes with conditions No
Publication Dates: _____

12/30/2024

To Whom it May Concern:

The North Dakota Information Technology Department has entered into a contract with Allo Towers of Irvine, California to construct towers for utilization on the Statewide Interoperable Radio Network (SIRN). As part of the contract with the state of North Dakota Allo Towers will be:

- Acquiring easements and completing land acquisitions or land leases.
- Designing, constructing, and maintaining the towers and compounds.

The North Dakota Information Technology Department will lease tower and compound space from Allo Towers.

The Statewide Interoperable Radio Network will be utilized by emergency responders such as law enforcement, fire, emergency medical, and other emergency responders. More information on the SIRN project can be found at: [SIRN 20/20 | North Dakota Information Technology \(nd.gov\)](#)

For more information please email: ndsirn@nd.gov or contact:

Jared Lemieux, SIRN Program Administrator

jarlemieux@nd.gov

701-328-6097 (office)

701-805-9817 (cellular)

Eric Pederson, Public Safety Manager

eipederson@nd.gov

701-328-1104 (office)

701-204-3756 (cellular)

Thank you,

Jared Lemieux

Jared Lemieux

Statewide Interoperable Radio Network Program Administrator

North Dakota Information Technology

Signature: 
Jared Lemieux (Dec 30, 2024 10:58 CST)

Email: jarlemieux@nd.gov

Valley City Planning Commission – October 14, 2025 Agenda

Action Request: Conditional Use Permit

Applicant: Allo Towers

Objective: Approve installation of a wireless communication facility on a tract of land owned by the City of Valley City and being leased to Allow Towers.

Property Owners: City of Valley City

Legal Description: Auditors Lot 1 and the south 360 feet of the east 820 feet of Auditor’s Lot 2 both of the NW ¼ of Section 32 Twp 140N Rng 58W in Barnes County, North Dakota, having an area of approximately 65.39 acres.

Project Location: The site of the proposed wireless communications facility is just east of County Road 19 and north of part of the Valley City sewage lagoons. See maps below.

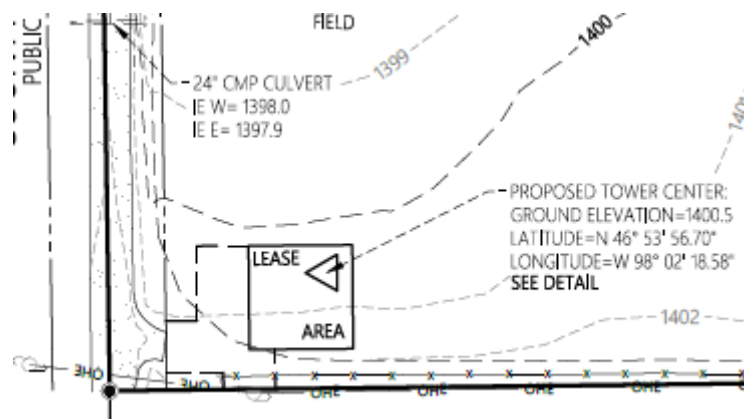
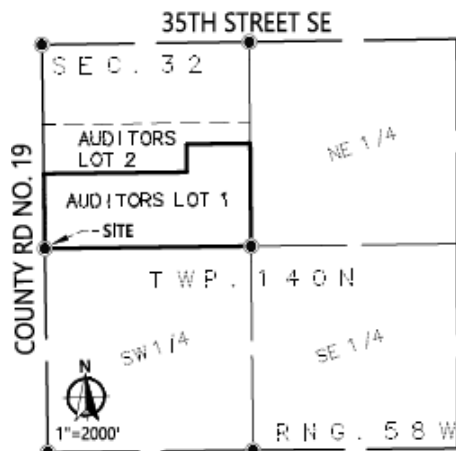

Analysis: The site of the proposed wireless communications facility is owned by Valley City and being leased to Allow Towers. In a separate application the land owned by Valley City is requested for zoning to the Agricultural District. The agricultural district lists wireless communication facilities on its conditional use list.

As part of an upgrade to the state-wide public communications system, the State of North Dakota needs to construct a wireless communications tower in the Valley City area for state, regional, and local first responders to use.

Conditional uses must be judged for their compatibility with other uses of the zoning district in which they are located and may require conditions for approval to address potential concerns or mitigation of incompatibility. The intent of the Agricultural District is for agricultural activities and other open land uses in proximity to land within the city's urbanized area. It also is to direct non-farm development to other places more appropriate for compact development and integration into the City of Valley City. The existing uses of agriculture and sewage lagoons are compatible with the wireless communications facility. A proposed conditional use should be evaluated for potential adverse effects. One potential adverse effect is that the proposed height of the tower is up to 255 feet, which is above the 199 feet maximum height standard that is commonly established for aviation safety. At the time of this report writing there is no certain confirmation as to the actual maximum height for construction at this site. Approval by the FAA of the proposed construction and height is pending. Another common concern for towers such as these has to do with impacts if there was a structural failure. The proposed lattice style tower is designed to collapse on itself instead of breaking at ground level and falling full length in any direction. At the time of this report writing, the distance of the lease site from County Road 19 is not fully determined, but it appears that the site would be less than 255 feet from the road. Access to the leased site is intended to be via an existing approach off of County Road 19 with appropriate access easement granted between the lease site and the road.

Findings:

- A. The proposed conditional use permit is appropriate in the Agricultural District, and if the Agricultural District zoning classification is approved will support the installation of the wireless communications tower.
- B. There is some level of risk that a structural failure would result in the tower collapsing onto County Road 19 and disrupting travel on the road. This can be mitigated by requiring the leased site to be located further to the east from County Road 19.
- C. The CUP application is for a tower up to 255 feet in height. This is not consistent with common height limitations for similar towers.

Recommendation:

Barring additional information presented prior to or at the October 2025 Planning and Zoning Commission, it is recommended the proposed Conditional Use permit be approved and recommended for approval to the Board of City Commissioners with the following conditions:

- 1. The proposed tower and tower height are approved by the FAA, and meet all FAA requirements such as installation of appropriate lighting or beacons to warn aircraft of the potential hazard.
- 2. The proposed tower lease site be at least 280 feet east of the County Road 19 right-of-way.

3. The Barnes County Municipal Airport manager does not indicate any reservations or objections to the installation if the previous two conditions are met.
4. The City Commission of Valley City approve the proposed Agricultural District zoning classification of the tract in which the wireless communication facility is proposed to be located.
5. Any additional issues identified at the October 14th public hearing are addressed to the satisfaction of the Planning and Zoning Commission.

SECTION 1: GENERAL REQUIREMENTS

1.1 PURPOSE AND INTENT

A. THE DRAWINGS ARE SUPPLEMENTAL TO ANY WRITTEN SPECIFICATIONS OR REQUIREMENTS. SHOULD ANYTHING BE SHOWN, INDICATED, OR SPECIFIED IN ONE AND NOT THE OTHER, OR IF ANY DISCREPANCIES OR DISAGREEMENTS ARE IDENTIFIED, THIS SHOULD BE BROUGHT TO THE ATTENTION OF THE OWNER AND/OR ENGINEER.

B. THE CONTRACTOR SHALL INCLUDE ALL LABOR AND MATERIALS NECESSARY FOR THE PROPER EXECUTION AND COMPLETION OF THE WORK.

1.2 CONFLICTS

A. THE CONTRACTOR SHALL BE RESPONSIBLE FOR VERIFYING ALL MEASUREMENTS AT THE SITE BEFORE ORDERING MATERIALS OR DOING ANY WORK. NO EXTRA COMPENSATION WILL BE ALLOWED DUE TO DIFFERENCES BETWEEN ACTUAL DIMENSIONS AND DIMENSIONS SHOWN ON THE PLANS. CONTRACTOR MUST SUBMIT NOTICE OF ANY DISCREPANCY IN DIMENSIONS TO OWNER FOR RESOLUTION BEFORE PROCEEDING WITH THE WORK IN THE AFFECTED AREAS.

B. THE CONTRACTOR IS REQUIRED TO VISIT THE SITE TO ASSESS CONDITIONS PRIOR TO BIDDING. IN ADDITION, CONTRACTOR SHALL PERFORM TESTING AND ADDITIONAL INVESTIGATION AS DEEMED NECESSARY TO SUBMIT A FIXED BID. IGNORANCE OF THE SITE OR PROJECT CONDITIONS WILL NOT BE GROUNDS FOR CHANGE ORDERS OR ALTERING THE SCHEDULE.

1.3 CLEANUP

A. THE CONTRACTOR SHALL KEEP THE SITE FREE FROM ACCUMULATION OF WASTE CAUSED BY EMPLOYEES. AT THE COMPLETION OF THE WORK, REMOVE ALL WASTE AND NON-CONSTRUCTION MATERIAL, INCLUDING ALL CONTRACTOR TOOLS. LEAVE THE SITE CLEAN AND READY FOR USE.

B. IF CLEARING IS REQUIRED, ALL BRUSH, STUMPS, AND OTHER WASTE MATERIAL SHALL BE REMOVED FROM THE SITE AND DISPOSED OF PROPERLY. THE OWNER SHALL BE CONSULTED FOR SPECIFICATIONS ON TREE PLACEMENT AND DISPOSAL. IF REQUIREMENTS ARE NOT SPECIFIED, A CONSERVATIVE ASSUMPTION SHALL BE UTILIZED FOR BIDDING PURPOSES.

C. THE SITE SHALL BE LEFT IN A CONDITION EQUIVALENT TO THE PRE-CONSTRUCTION CONDITION AND SATISFACTORY TO THE OWNER.

1.4 CODES

A. CONTRACTOR SHALL BE RESPONSIBLE FOR FOLLOWING ALL FEDERAL, STATE, AND LOCAL LAWS, REGULATIONS, AND RULES. THIS RESPONSIBILITY IS IN EFFECT REGARDLESS OF WHETHER THE LAW, ORDINANCE, REGULATION OR RULE IS MENTIONED IN THE DRAWINGS OR WRITTEN SPECIFICATIONS.

B. IN ADDITION TO ALL CODES, CONTRACTOR SHALL FOLLOW ALL MANUFACTURER RECOMMENDATIONS AND APPLICABLE STANDARDS (ACI, IBC, NEC, ETC).

1.5 QUALITY ASSURANCE

A. THE CONTRACTOR SHALL PROVIDE A PROJECT SCHEDULE PRIOR TO COMMENCING ANY WORK. IN ADDITION, THE CONTRACTOR SHALL NOTIFY THE OWNER OF ANY CHANGES TO THE SCHEDULE AS SOON AS THEY ARE KNOWN. THE CONTRACTOR SHALL PROVIDE 48-HOUR ADVANCE NOTICE OF SPECIFIC INSPECTION MILESTONES (SUCH AS FOUNDATION POURING). ADVANCE NOTICE WILL ALLOW FOR COORDINATION WITH INSPECTION COMPANIES.

PRIOR TO COMMENCING WORK, THE CONTRACTOR SHALL REQUEST A LIST OF INSPECTIONS FROM THE OWNER OR ENGINEER. AT A MINIMUM THIS WILL TYPICALLY INCLUDE THE FOUNDATION, GROUNDING, SUBSTANTIAL COMPLETION, AND FINAL.

B. THE CONTRACTOR SHALL TAKE PHOTOGRAPHS OF ALL COMPLETED WORK AND PROVIDE THESE TO THE OWNER ON A WEEKLY BASIS. PHOTOGRAPHS SHALL INCLUDE DOCUMENTATION OF ALL SUBGRADE WORK THAT CANNOT BE VISIBLY INSPECTED UPON COMPLETION (GROUNDING, FOUNDATION, UTILITIES, ETC.).

C. THE CONTRACTOR IS THE GUARANTOR OF ALL WORK. FAILURE TO IDENTIFY A DISCREPANCY/DEFECT OR IMMEDIATELY NOTIFY THE CONTRACTOR OF SAID DEFECT DOES NOT RELIEVE THE CONTRACTOR OF ANY RESPONSIBILITIES IN THIS REGARD.

D. IT IS THE CONTRACTOR'S RESPONSIBILITY TO ENSURE THAT INSPECTIONS OCCUR PRIOR TO COMPLETION OF WORK. IF AN ITEM IS COMPLETED WITHOUT THE REQUESTED INSPECTION, THE OWNER WILL HAVE THE RIGHT TO ASSUME THAT THE WORK WAS NOT COMPLETED PROPERLY AND MUST BE REPLACED.

1.6 BUILDING PERMITS

THE CONTRACTOR IS RESPONSIBLE TO OBTAIN THE BUILDING PERMIT. CONTRACTOR SHALL COORDINATE AND SCHEDULE REQUIRED INSPECTIONS AT THE JOB SITE, COMPLY WITH SPECIFIC PROJECT RELATED REQUESTS AND SUGGESTIONS MADE BY BUILDING INSPECTOR, AND INFORM THE OWNER OF ANY REQUIREMENTS THAT MAY DEVIATE FROM THE CONSTRUCTION DOCUMENTS.

1.7 FAA PERMIT AND TOWER LIGHTING

REFER TO CONSTRUCTION DOCUMENTS AND CONSTRUCTION MANAGER FOR FAA AND STATE LIGHTING REQUIREMENTS. CONTRACTOR SHALL PROVIDE TEMPORARY FAA APPROVED LIGHTING UNTIL PERMANENT LIGHTING IS OPERATIONAL. THE CONTRACTOR SHALL ENSURE THAT ANY FAA ELEVATION LIMITATIONS ARE NOT EXCEEDED.

1.8 TOWER SECURITY

THE CONTRACTOR IS RESPONSIBLE FOR SITE SECURITY THROUGHOUT THE CONSTRUCTION PHASE. THE SITE MUST BE SECURELY FENCED (PERMANENTLY OR TEMPORARILY) WITHIN 24 HOURS OF TOWER ERECTION.

1.9 SITE CONTROL

A. THE CONTRACTOR IS COMPLETELY RESPONSIBLE FOR CONTAINMENT OF SEDIMENT AND CONTROL OF EROSION AT THE SITE. ANY DAMAGE TO ADJACENT OR DOWNSTREAM PROPERTIES WILL BE CORRECTED BY THE CONTRACTOR AT NO ADDITIONAL EXPENSE TO OWNER.

B. IF WETLANDS ARE PRESENT IN THE PROJECT VICINITY THE CONTRACTOR IS RESPONSIBLE TO TAKE ALL NECESSARY PRECAUTIONS TO ENSURE THAT THEY ARE NOT DISTURBED IN ANY MANNER. IF DISTURBANCE OCCURS, THE CONTRACTOR SHALL BE RESPONSIBLE FOR ALL COSTS AND CONSEQUENCES, INCLUDING FINES (EVEN IF ASSESSED TO THE OWNER).

C. THE CONTRACTOR IS TO MAINTAIN ADEQUATE DRAINAGE AT ALL TIMES. DO NOT ALLOW WATER TO STAND OR POND. ANY DAMAGE TO STRUCTURES OR THE SITE CAUSED BY INADEQUATE MAINTENANCE OF DRAINAGE PROVISIONS WILL BE THE RESPONSIBILITY OF CONTRACTOR.

D. THE CONTRACTOR SHALL CONTAIN ALL CONSTRUCTION ACTIVITIES, MATERIALS, EQUIPMENT, ETC. TO THE LEASED AREA AND LEGAL EASEMENTS UNLESS PERMISSION TO DO OTHERWISE IS GRANTED BY THE PROPERTY OWNER.

1.10 CHANGE ORDER PROCEDURE

THE CONTRACTOR MUST PROVIDE NOTICE IN WRITING ON PROPER FORMS OF ANY POTENTIAL CLAIM FOR CONCEALED OR UNKNOWN CONDITIONS, OR ANY OTHER ITEM (EVEN IF A REQUEST BY OWNER) THAT MAY RESULT IN A TIME DELAY OR COST CHANGE WITHIN 1 DAY OF FIRST KNOWLEDGE. ANY CLAIM (CHANGE ORDER) MUST BE APPROVED BY THE OWNER PRIOR TO PROCEEDING OR INCURRING ANY COSTS. ANY CHANGES IN SCOPE OF WORK OR MATERIALS WHICH ARE PERFORMED BY THE CONTRACTOR WITHOUT WRITTEN APPROVAL BY THE OWNER SHALL PLACE FULL RESPONSIBILITY OF THESE ACTIONS ON THE CONTRACTOR AND ANY ASSOCIATED COST INCURRED WILL NOT BE PAID.

SECTION 2: EARTHWORK

2.1 SCOPE OF WORK

REFER TO THE SURVEY AND SITE PLAN FOR EXISTING GRADES AND FINAL ELEVATIONS.

2.2 SITE PREPARATION

A. CLEAR TREES, BRUSH AND DEBRIS FROM COMPOUND, ACCESS DRIVE, AND UTILITY PATH AS REQUIRED. SEE SITE PLAN FOR APPROPRIATE AREA TO BE CLEARED. REMOVE STUMPS, ORGANIC SOIL, AND OTHER DETRIMENTAL MATERIAL COMPLETELY UNDER ENTIRE COMPOUND AND DRIVE. ALL WASTE MATERIALS INCLUDING, BUT NOT LIMITED TO, STUMPS AND DEBRIS SHALL BE REMOVED FROM THE PROPERTY AND DISPOSED OF PROPERLY.

B. STRIP ALL ORGANIC MATERIAL FROM COMPOUND AND ACCESS DRIVE. IF SITE CONTAINS WET SOIL, CONTRACTOR SHALL OVER EXCAVATE A MINIMUM OF 18 INCHES OF MATERIAL FROM THE ENTIRE COMPOUND AND ACCESS DRIVE.

C. PRIOR TO PLACEMENT OF FILL OR BASE MATERIALS, CONTRACTOR SHALL REMOVE ALL TOPSOIL, ORGANIC MATERIALS AND WET OR POOR SOILS. IF MORE THAN 2'-0" OF POOR SOILS ARE ENCOUNTERED, CONTRACTOR SHOULD IMMEDIATELY CONTACT CONSTRUCTION MANAGER AND/OR ENGINEER FOR GUIDANCE.

D. CONTRACTOR SHALL FOLLOW RECOMMENDATIONS CONTAINED IN PLANS AND GEOTECHNICAL REPORT.

2.3 EXCAVATION

A. CONTRACTOR SHALL EXCAVATE TO DEPTH, AND GRADES SHOWN ON THE PLANS.

MINIMUM COMPACTION SHALL BE 90% MAXIMUM DRY DENSITY IN ACCORDANCE WITH ASTM D-1557 FOR SITE WORK AND 95% MAXIMUM DRY DENSITY UNDER STRUCTURAL ELEMENTS. AREAS OF SETTLEMENT IDENTIFIED WITHIN ONE YEAR OF ACCEPTANCE OF FINAL CONSTRUCTION BY OWNER WILL BE EXCAVATED, FILLED, AND RECOMPACTED AT CONTRACTOR'S EXPENSE.

B. CONTRACTOR SHALL REVIEW THE GRADING PLANS, GEOTECHNICAL REPORT, AND TOWER FOUNDATION PLANS THOROUGHLY PRIOR TO BIDDING. ANY DISCREPANCIES OR INCONSISTENCIES SHOULD BE BROUGHT TO THE IMMEDIATE ATTENTION OF THE ENGINEER.

C. IT IS RECOMMENDED THAT THE OWNER HIRE AN INDEPENDENT GEOTECHNICAL ENGINEER TO REVIEW SOIL CONDITIONS AND AN ACI CERTIFIED INSPECTOR TO REVIEW ALL FOUNDATION ELEMENTS.

D. REGARDLESS OF THE ABOVE RECOMMENDATION, THE CONTRACTOR IS RESPONSIBLE TO OBSERVE SITE AND SOIL CONDITIONS THROUGHOUT THE CONSTRUCTION PROCESS AND COMPARE THE ABOVE TO THE GEOTECHNICAL REPORT, THE PLANS, AND THE TOWER DRAWINGS. ANY INCONSISTENCIES, DISCREPANCIES, OR ASSUMPTIONS THAT PROVE TO BE INCORRECT, SHALL BE BROUGHT TO THE IMMEDIATE ATTENTION OF THE ENGINEER.

2.4 SITE GRADING

ANY INCONSISTENCIES BETWEEN THE GEOTECHNICAL REPORT, SITE DRAWINGS, TOWER PLANS, AND SPECIFICATIONS SHALL BE RESOLVED IN FAVOR OF THE STRICTER REQUIREMENT.

A. CONTRACTOR SHALL USE ON-SITE MATERIALS OR IMPORTED FILL TO MATCH THE LINES, GRADES, AND CROSS SECTIONS SHOWN ON THE DRAWINGS. HOWEVER, IN NO CASE SHALL ORGANIC MATERIALS, WET SOIL, FROZEN SOIL, OR POOR SOIL BE USED AS ON-SITE FILL. IN ADDITION, ALL FILL (ON-SITE OR IMPORTED) SHALL BE ADEQUATELY COMPACTED PER THE EARTHWORK SPECIFICATIONS.

B. IF DISCREPANCIES ARE IDENTIFIED BETWEEN THE GRADING PLAN AND ACTUAL SITE CONDITIONS, THESE SHOULD BE BROUGHT TO THE ATTENTION OF THE ENGINEER PRIOR TO PROCEEDING WITH WORK. ANY CHANGES TO THE GRADING PLAN CONTOURS MUST BE PREAPPROVED.

C. THE CONTRACTOR SHALL LIMIT ALL SITE GRADING AND CONSTRUCTION ACTIVITIES TO THE LEASED AREA AND ASSOCIATED EASEMENT. IF THIS IS NOT POSSIBLE, CONTACT THE PROJECT MANAGER AND OBTAIN OWNER APPROVAL PRIOR TO WORKING OUTSIDE THE ABOVE LIMITS.

D. REGARDLESS OF THE CONTOURS DEPICTED IN THE PLANS, ALL REQUIREMENTS IN THE TOWER FOUNDATION DRAWINGS (INCLUDING THE MINIMUM SOIL COVER) MUST BE ADHERED TO STRICTLY.

E. ALL FINISHED SURFACES SHOULD BE GRADED TO DRAIN FROM FOUNDATION. PROVIDE PROPER DITCHING AND ROUTING OF SURFACE WATER, AND AVOID PONDING AND EROSION.

F. ALL EXPOSED SOIL SHALL BE PROPERLY SEEDED AND PROTECTED FROM EROSION.

G. THE FINISHED GRADE SHALL EXTEND A MINIMUM OF ONE FOOT BEYOND THE COMPOUND FENCE.

2.5 GRAVEL SURFACING

A. CONSTRUCT GRAVEL DRIVE AND COMPOUND AREAS USING CRUSHED AGGREGATE BASE AND FINISH COURSES AS SPECIFIED IN THE CONSTRUCTION DOCUMENTS OR AS DIRECTED BY THE CONSTRUCTION MANAGER.

B. PLACE FILL OR STONE IN MAXIMUM EIGHT INCH LIFTS AND COMPACT TO SPECIFIED DENSITY PRIOR TO PLACING NEXT LIFT.

2.6 RETAINING WALLS

A. RETAINING WALLS TO BE INSTALLED BY AN EXPERIENCED CONTRACTOR FAMILIAR WITH AT LEAST TEN (10) PROJECTS OF SIMILAR SIZE AND SCOPE.

B. CONTRACTOR SHALL FOLLOW ALL MANUFACTURER DESIGN CHARTS AND INSTALLATION GUIDELINES.

C. ALL BACKFILLED MATERIAL SHALL BE QUALITY SOILS (SAND, GRAVEL, OR SILTY SAND) WITH A MINIMUM SOIL BEARING CAPACITY OF 2,500 P.S.F. LL BACKFILLED MATERIAL SHALL BE COMPACTED TO 95% STANDARD PROCTOR IN MAXIMUM 8" LIFTS.

D. DRAINAGE TILE SHALL BE USED BEHIND THE RETAINING WALL. THE DRAINAGE TILE SHALL RUN TO DAYLIGHT AT A MAXIMUM INTERVAL OF 20'. WHEN SITE CONDITIONS REQUIRE, WRAP DRAINAGE TILE IN 3/4" CRUSHED AGGREGATE AND FILTER FABRIC WITH DRAINAGE COMPOSITE OR AGGREGATE BACK DRAIN.

E. RETAINING WALL EMBEDMENT SHALL BE AT LEAST THE MINIMUM SPECIFIED IN THE DRAWINGS. IN ADDITION, MINIMUM EMBEDMENT MUST EXCEED ANY MANUFACTURER DESIGN GUIDELINES.

F. ALL GEOGRID MATERIAL IS TO BE COATED POLYESTER WITH A MINIMUM ALLOWABLE DESIGN STRENGTH OF LTDS = 1350 PK.

CONSULTANT:



CLIENT:



ENGINEER SEAL:



I HEREBY CERTIFY THAT THIS PLAN SET WAS PREPARED BY ME OR UNDER MY DIRECT SUPERVISION OTHER THAN THE EXCEPTIONS NOTED IN THE SHEET INDEX, AND THAT I AM A DULY LICENSED PROFESSIONAL ENGINEER UNDER THE LAWS OF THE STATE OF NORTH DAKOTA.

GENERAL SPECIFICATIONS
SIERRA (ND240019)
VALLEY CITY, NORTH DAKOTA

SUBMITTAL:

INT.	DATE:	DESCRIPTION:
TJT	09/16/25	REV A

CHECKED BY:	OGD
PLOT DATE:	9/16/2025
PROJECT NUMBER:	44155
SET TYPE:	PRELIM
SHEET NUMBER:	G-002

SECTION 3: TRENCHING

3.1 MATERIALS

FILL MATERIALS SHALL BE OBTAINED, WHEN POSSIBLE, FROM MATERIALS EXCAVATED FROM TRENCHES ON-SITE. STRUCTURAL FILL, SAND OR SLURRY SHALL BE APPROVED BY THE CONSTRUCTION MANAGER AND SHALL CONFORM TO LOCAL UTILITY COMPANY REQUIREMENTS. THE FILL MATERIAL SHALL CONTAIN NO ORGANIC MATERIALS OR ROCKS. ALL FILL MATERIAL SHALL BE FREE OF OBJECTIONABLE MATERIALS AND/OR MATERIALS DESIGNATED AS HAZARDOUS OR POTENTIALLY HAZARDOUS. THE FILL MATERIAL SHALL CONTAIN FINES SUFFICIENT TO FILL ALL VOIDS IN THE MATERIAL. COMPACTION OF SOIL SHALL BE IN 8 INCH LOOSE LIFTS WHEN UTILIZING HEAVY COMPACTION EQUIPMENT OR 6 INCH LOOSE LIFTS WHEN UTILIZING HAND OPERATED TAMPERS.

3.2 PIPE DETECTION AND IDENTIFICATION

ALL ELECTRIC SERVICE TRENCHES SHALL BE MARKED WITH DETECTABLE WARNING TAPE.

3.3 TRENCH EXCAVATION

- A. DIG TRENCH TO DEPTHS AND GRADES SHOWN ON THE PLANS OR AS DIRECTED BY THE CONSTRUCTION MANAGER.
- B. TRENCH LENGTH SHALL BE SUFFICIENT TO ALLOW FOR SATISFACTORY CONSTRUCTION AND INSPECTION OF THE PROJECT, WITHOUT ENDANGERING OTHER CONSTRUCTION WORK OR ADJACENT FACILITIES.
- C. DISPOSE OF EXCESS AND UNSUITABLE EXCAVATION MATERIAL PROPERLY.
- D. USE HAND EXCAVATION METHODS WHEN REQUIRED BY LOCAL OR STATE GUIDELINES, OR WHEN NECESSARY TO AVOID ENDANGERING EXISTING OR NEW STRUCTURES OR OTHER FACILITIES.

3.4 TRENCH PROTECTION

- A. PROVIDE MATERIALS, LABOR, AND EQUIPMENT NECESSARY TO PROTECT TRENCHES AT ALL TIMES.
- B. SHEETING AND BRACING SHOULD MEET OR EXCEED OSHA REQUIREMENTS.

3.5 BACKFILLING

- A. CONTRACTOR SHALL NOTIFY THE CONSTRUCTION MANAGER AT LEAST 24 HOURS IN ADVANCE OF BACKFILLING.
- B. PROTECT CONDUIT FROM LATERAL MOVEMENT, DAMAGE FROM IMPACT, OR UNBALANCED LOADING TO AVOID DISPLACEMENT OF CONDUIT AND/OR STRUCTURES. DO NOT FREE FALL BACKFILL INTO TRENCH UNTIL THERE IS AT LEAST 12 INCHES OF COVER OVER THE CONDUIT.

3.6 COMPACTION

- A. COMPACT BACKFILL TO AT LEAST 95% STANDARD PROCTOR.
- B. IF REQUIRED COMPACTION DENSITY IS NOT OBTAINED, REMOVE BACKFILL FROM TRENCH, REPLACE WITH APPROVED BACKFILL, AND RECOMPACT AS SPECIFIED.
- C. ANY SUBSEQUENT SETTLEMENT OF TRENCH OR BACKFILL DURING MAINTENANCE PERIOD (1 YEAR MINIMUM) SHALL BE REMOVED, REPLACED, AND RECOMPACTED BY CONTRACTOR AT NO ADDITIONAL EXPENSE TO OWNER.

SECTION 4: CONCRETE WORK

4.1 CONCRETE FORMWORK

CONTRACTOR SHALL FOLLOW ALL APPLICABLE CODES AND STANDARDS (IBC, ACI, ETC.) WHEN COMPLETING CONCRETE WORK.

- A. FORMS SHALL BE SMOOTH AND FREE OF SURFACE IRREGULARITIES. CONTRACTOR SHALL UTILIZE FORM RELEASE AGENTS AS NECESSARY.
- B. EXPOSED EDGES OF ALL TOWER FOUNDATIONS SHALL RECEIVE A 3/4" CHAMFER. OTHER EXPOSED EDGES SHALL RECEIVE A TOOLED RADIUS FINISH.
- C. UPON COMPLETION, CONTRACTOR SHALL REMOVE ALL FORMS, INCLUDING THOSE CONCEALED OR BURIED.
- D. REFER TO PLANS AND TOWER DRAWINGS FOR ADDITIONAL REQUIREMENTS.

4.2 CONCRETE REINFORCEMENT

REFER TO PLANS AND TOWER DRAWINGS FOR REINFORCEMENT REQUIREMENTS.

4.3 CAST-IN-PLACE CONCRETE

REFER TO STRUCTURAL DRAWINGS FOR CONCRETE REQUIREMENTS FOR FOOTINGS, FOUNDATIONS, ETC. ANY NON-STRUCTURAL SITE CONCRETE SHALL HAVE A MINIMUM COMPRESSIVE STRENGTH OF 3,000 PSI.

- A. ALL CONCRETE SUBJECT TO FREEZE-THAW SHALL CONTAIN 4-8% AIR ENTRAINMENT.
- B. ALL CONCRETE SHALL BE VIBRATED IN PLACE USING HIGH FREQUENCY, LOW AMPLITUDE MECHANICAL IMMERSION TYPE VIBRATORS. INSERT VIBRATORS IN CONCRETE AT REGULAR INTERVALS AND OVER ENTIRE SURFACE TO SOLIDLY FILL AROUND AND BETWEEN REINFORCEMENT AND INTO CORNERS AND IRREGULARITIES. DISCONTINUE VIBRATION WHEN RISING ENTRAPPED AIR BUBBLES STOP BREAKING THE LEVELING SURFACE. DO NOT OVERVIBRATE AS THIS MAY CAUSE SEGREGATION.

4.4 QUALITY CONTROL

- A. ALL STRUCTURAL CONCRETE SHALL BE INSPECTED BY INDEPENDENT, QUALIFIED PERSONNEL (ACI OR OTHERWISE). ALL STRUCTURAL CONCRETE SHALL BE TESTED BY AN INDEPENDENT LAB. AT A MINIMUM, 5 CYLINDERS SHALL BE CAST AND TESTED AT 7, 14, AND 28 DAYS. THE REMAINING CYLINDER SHALL BE RESERVED FOR RE-TESTING, IF NECESSARY.

THE CONTRACTOR IS RESPONSIBLE FOR COORDINATION WITH THE CONSTRUCTION MANAGER AND/OR TESTING AGENCY A MINIMUM OF 48 HOURS PRIOR TO EACH FOUNDATION POUR. IF A POUR OCCURS WITHOUT THE REQUESTED INSPECTION, THE OWNER CAN ASSUME THAT THE INSTALLATION WAS NOT INSTALLED CORRECTLY AND REQUIRE REPLACEMENT.

- B. THE CONTRACTOR SHALL BE RESPONSIBLE TO REMOVE AND REPLACE, AT HIS SOLE EXPENSE, ANY CONCRETE THAT DOES NOT MEET THE ABOVE SPECIFICATIONS, OR SIMILAR SPECIFICATIONS CONTAINED IN THE PLANS OR TOWER DRAWINGS. ANY CONCRETE THAT DOES NOT MEET THE MINIMUM COMPRESSIVE STRENGTH REQUIRED UPON COMPLETION OF LAB TESTING SHALL BE REPLACED. THE AVERAGE OF THE TWO 28 DAY BREAK RESULTS SHALL GOVERN. NO DISPUTES REGARDING THE METHOD USED TO COLLECT THE TEST CYLINDERS OR PERFORM THE LAB TESTING ARE ALLOWED. IF THE CONTRACTOR CHOOSES, HE MAY COLLECT AND TEST ADDITIONAL CYLINDERS AT HIS SOLE EXPENSE.
- C. DESPITE THE ABOVE REQUIREMENT, THE CONTRACTOR IS RESPONSIBLE TO PERFORM QUALITY WORK AND IS THE GUARANTOR OF THE FINISHED PRODUCT. IF A DEFECT IS NOT IMMEDIATELY IDENTIFIED BY THE INSPECTOR, OWNER, OR CONSTRUCTION MANAGER, BUT IDENTIFIED SUBSEQUENTLY, THE CONTRACTOR SHALL STILL BE RESPONSIBLE TO CORRECT SAID DEFECT.
- D. CONTRACTOR MUST VERIFY THAT CONCRETE MEETS DESIGN REQUIREMENT (FOR STRENGTH AND OTHER PARAMETERS) BEFORE PLACING ANY SERVICE LOADS.

SECTION 5: STRUCTURAL STEEL

- A. UNLESS OTHERWISE NOTED, ALL DETAILING, FABRICATION AND PLACING OF REINFORCING STEEL SHALL CONFORM TO THE MANUAL OF STANDARD PRACTICE FOR DETAILING REINFORCED CONCRETE STRUCTURES (ACI 315).
- B. ALL REINFORCING STEEL SHALL BE NEW BILLET STEEL, CONFORMING TO ASTM A-615, GRADE 60, DEFORMED.
- C. HEATING AND WELDING OF BARS IS PROHIBITED UNLESS WRITTEN APPROVAL IS OBTAINED FROM THE STRUCTURAL ENGINEER.
- D. ALL REINFORCEMENT BARS ARE TO BE FREE FROM LOOSE RUST AND SCALE.
- E. UNLESS OTHERWISE NOTED, ALL REINFORCEMENT SHALL HAVE A MINIMUM CONCRETE COVER OF 3 INCHES. CONTRACTOR SHALL UTILIZE SPACERS AND CHAIRS AS REQUIRED.
- F. SPLICES IN REINFORCEMENT STEEL ARE PROHIBITED, UNLESS APPROVED BY THE STRUCTURAL ENGINEER. ALL SPLICES MUST THEN MEET ALL APPLICABLE ASTM STANDARDS FOR SPLICING.
- G. WELDING SHALL BE IN ACCORDANCE WITH THE AMERICAN WELDING SOCIETY (AWG) D.1.1-92. STRUCTURAL WELDING CODE.

SECTION 6: GROUNDING

- A. GROUND RING IS TO BE CONSTRUCTED OF MATERIALS INDICATED ON THE DRAWINGS. ALL ABOVE GROUND LEADS TO BE SEALED IN CARFLEX CONDUITS.
- B. GROUND ALL CORNER POSTS WITH EXOTHERMIC WELDS (CONNECTION TO BE NO MORE THAN 12 INCHES ABOVE GROUND BUT MUST BE VISIBLE).
- C. ICE BRIDGE GROUND - GROUND SUPPORT POST TO GROUND RING AND GROUND ICE BRIDGE TO THE POST.
- D. A SMOOTH, DOWNWARD PATH TO GROUND IS REQUIRED FOR ALL GROUND LEADS.
- E. CONTRACTOR TO BOND PROPOSED GROUND SYSTEM TO EQUIPMENT/BUILDING GROUND RING IN 2 LOCATIONS.
- F. PROPOSED GROUND RING SHALL BE INSTALLED A MINIMUM OF 2' FROM ANY STRUCTURE.
- G. AT BASE OF ANTENNA TOWER, ATTACH GROUND KITS FROM COAXIAL CABLES TO TOWER GROUND BAR. LOCATE GROUND RING AROUND TOWER AND BOND GROUND BAR TO GROUND RING AS INDICATED ON DRAWINGS. CONTRACTOR TO PROVIDE GROUND BAR AND ALL MOUNTING HARDWARE.
- H. DOUBLING UP OR "STACKING" OF CONNECTION IS NOT PERMITTED.

- I. OXIDE INHIBITING COMPOUND TO BE USED AT ALL CONNECTIONS.
- J. RESISTIVITY TEST SHALL BE PERFORMED BY THE CONTRACTOR PRIOR TO BACKFILLING. A MAXIMUM RESISTIVITY OF 5 OHMS MUST BE ACHIEVED PRIOR TO PROCEEDING. THE RESULTS OF THIS TEST SHALL BE DOCUMENTED, WITH COPIES PROVIDED TO THE OWNER AND CONSTRUCTION MANAGER.
- K. DO NOT INSTALL BURIED GROUND RING OUTSIDE OF THE LEASED AREA. CONTRACTOR SHALL NOTIFY THE OWNER 24 HOURS IN ADVANCE OF THE GROUND RING INSTALLATION SO THAT A REPRESENTATIVE CAN INSPECT THE GROUND RING BEFORE IT IS BACKFILLED. IF A REPRESENTATIVE IS NOT PRESENT, CONTRACTOR SHALL PHOTOGRAPH ENTIRE INSTALLATION AND PROVIDE PHOTOGRAPHS TO CONSTRUCTION MANAGER WITHIN 48 HOURS.

SECTION 7: ELECTRICAL

- A. PROVIDE 2 PULL STRINGS SECURELY FASTENED AT EACH END OF ALL CONDUITS.
- B. THE CONTRACTOR SHALL LOCATE AND MARK ALL EXISTING UNDERGROUND POWER, TELCO, GROUNDING CONDUITS, AND ALL OTHER UTILITY EASEMENTS AND/OR WIRES PRIOR TO TRENCHING. ANY DAMAGE CAUSED TO THE EXISTING UNDERGROUND SERVICES OR SYSTEMS SHALL BE REPAIRED AT THE CONTRACTOR'S SOLE EXPENSE.
- C. CONTRACTOR SHALL CONTACT UTILITY PROVIDER PRIOR TO BIDDING AND CONSTRUCTION TO VERIFY THAT SERVICE HAS BEEN ORDERED AND DISCUSS ANY SITE SPECIFIC REQUIREMENTS. CHANGE ORDERS RELATED TO UTILITY REQUIREMENTS OR REQUESTS WILL NOT BE ALLOWED UNLESS THIS CONDITION HAS BEEN MET.
- D. CONTRACTOR TO COORDINATE WITH UTILITY COMPANY FOR CONNECTION OF TEMPORARY AND PERMANENT POWER TO THE SITE. THE TEMPORARY POWER AND ALL HOOKUP COSTS SHALL BE PAID BY CONTRACTOR.
- E. ALL MATERIALS UTILIZED SHALL BE U.L. LISTED.

SECTION 8: TOWER AND ANTENNA INSTALLATION

- A. IF REQUIRED, ERECT FURNISHED TOWER. PRIOR TO ERECTION, CONTRACTOR MUST VERIFY THAT CONCRETE HAS MET THE MINIMUM STRENGTH REQUIREMENTS AS WELL AS ANY OTHER INSPECTION OR TESTING REQUIREMENTS.
- B. INSTALL ANTENNAS AND LINES AS INDICATED ON THE DRAWINGS AND PER OWNER SPECIFICATIONS.
- C. INSTALL ANTENNA AND COAX MOUNTING HARDWARE AS INDICATED ON THE DRAWINGS OR APPROVED BY THE CONSTRUCTION MANAGER.
- D. ASSIST OWNER TECHNICIANS IN PERFORMING SWEEP TEST OF INSTALLED COAX.
- E. ANTENNA INSTALLATION TO BE CONDUCTED BY FIELD CREWS EXPERIENCED IN THE ASSEMBLY AND ERECTION OF ANTENNAS, TRANSMISSION LINES AND SUPPORT STRUCTURES.
- F. CONTRACTOR SHALL FOLLOW ALL APPLICABLE STANDARDS INCLUDING, BUT NOT LIMITED TO: EIA 222 (LATEST VERSION), FAA ADVISORY CIRCULAR AC70/7460-1A, FCC RULES & REGULATIONS.

SECTION 9: LANDSCAPING & SITE RESTORATION

CONTRACTOR SHALL FURNISH, INSTALL, AND MAINTAIN LANDSCAPE WORK AS SHOWN ON THE CONSTRUCTION DRAWINGS OR REQUIRED IN THE SPECIFICATIONS.

CONTRACTOR SHALL UTILIZE THE SERVICES OF A LANDSCAPE CONTRACTOR TO ENSURE THE LANDSCAPING IS PROPERLY INSTALLED, WATERED, AND OTHERWISE MAINTAINED. CONTRACTOR SHALL GUARANTEE LANDSCAPING FOR A MINIMUM OF 1 YEAR AND SHALL REPLACE ANY DEAD OR VISIBLY DISTRESSED PLANTS WITHIN THIS PERIOD.

- 9.1 PROTECTION
 - A. CONTRACTOR SHALL PROTECT SEEDED AREAS FROM EROSION THROUGH THE USE OF AN EROSION CONTROL MESH OR MULCH NET.
 - B. ALL TREES PLACED IN CONJUNCTION WITH A LANDSCAPE PLAN WILL BE WRAPPED, TIED WITH HOSE PROTECTED WIRE AND SECURED TO A STEEL ANGLE EXTENDING TWO FEET INTO THE GROUND ON FOUR SIDES OF THE TREE.
 - C. ALL EXPOSED AREAS SHALL BE PROTECTED AGAINST WASHOUTS AND SOIL EROSION.
- 9.2 INSTALLATION
 - A. SEED AND FERTILIZER SHALL BE APPLIED TO SURFACE CONDITIONS TO ENCOURAGE ROOTING. RAKE AREAS TO BE SEEDED TO EVEN THE SURFACE AND LOOSEN THE SOIL.
 - B. SOW SEED IN TWO DIRECTIONS IN TWICE THE QUANTITY RECOMMENDED BY THE SEED PRODUCER.
 - C. IT IS THE CONTRACTOR'S RESPONSIBILITY TO ENSURE GROWTH OF SEEDED AND LANDSCAPED AREAS BY WATERING. CONTINUE TO REWORK BARE AREAS UNTIL COMPLETE COVERAGE IS OBTAINED.

CONSULTANT:

 Consulting Engineers, Inc.
 2101 HIGHWAY 13 W
 BURNSVILLE, MN 55337
 608.644.1449 VOICE
 608.644.1549 FAX
 www.edgeconsult.com

CLIENT:

 151 KALMUS DR., SUITE E-201
 COSTA MESA, CA 92626
 949.749.1994 VOICE
 www.allotowers.com

ENGINEER SEAL:

I HEREBY CERTIFY THAT THIS PLAN SET WAS PREPARED BY ME OR UNDER MY DIRECT SUPERVISION OTHER THAN THE EXCEPTIONS NOTED IN THE SHEET INDEX, AND THAT I AM A DULY LICENSED PROFESSIONAL ENGINEER UNDER THE LAWS OF THE STATE OF NORTH DAKOTA.

GENERAL SPECIFICATIONS
 SIERRA (ND240019)
 VALLEY CITY, NORTH DAKOTA

SUBMITTAL:		
INT.	DATE:	DESCRIPTION:
TJT	09/16/25	REV A
CHECKED BY:	OGD	
PLOT DATE:	9/16/2025	
PROJECT NUMBER:	44155	
SET TYPE:	PRELIM	
SHEET NUMBER:	G-003	

L:\44100\44155\Design\CAD\CD\Plot\G-003.dgn

SITE SURVEY

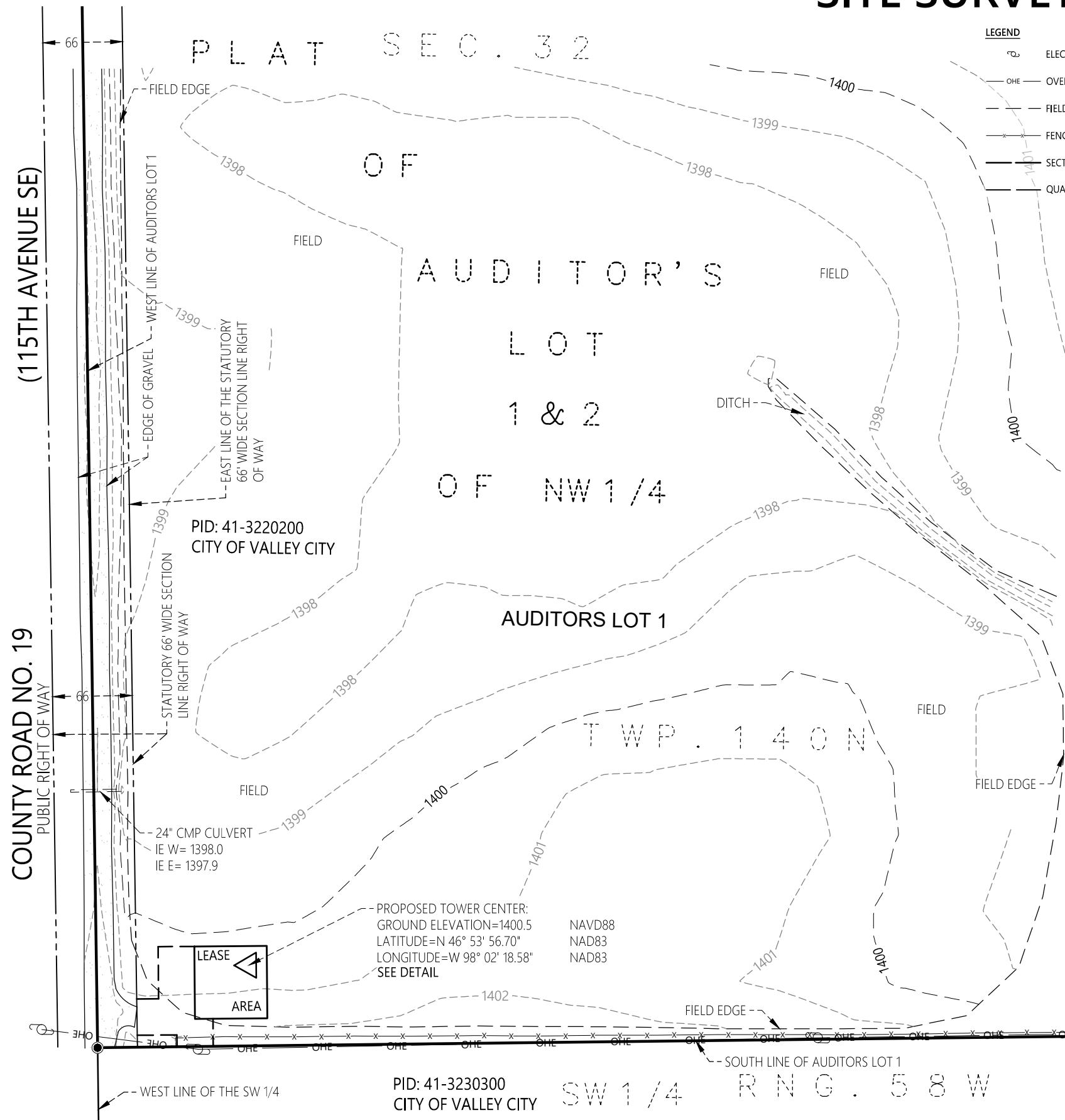

LEGEND

- ELECTRIC POLE
- OVERHEAD ELECTRIC WIRE
- FIELD EDGE
- FENCE - BARB WIRE
- SECTION LINE
- QUARTER (1/4) SECTION LINE
- RIGHT-OF-WAY LINE
- SUBJECT TRACT(S) BOUNDARY
- PLATTED BLOCK LINE(S)
- EASEMENT LINE
- LEASE LINE
- GRAVEL PAVEMENT

SURVEYOR NOTES:

- 1) THE UTILITIES SHOWN ON THIS SURVEY ARE ACCORDING TO VISIBLE EVIDENCE ALONG WITH MARKINGS FROM NORTH DAKOTA ONE CALL LOCATE REQUEST TICKET No. 25053835, DATED JUNE 2, 2025. WIDSETH ASSUMES NO RESPONSIBILITY FOR THE COMPLETENESS AND ACCURACY OF THESE LOCATIONS.
- 2) THIS DRAWING HAS BEEN SCALED FROM THE NORTH DAKOTA STATE PLANE COORDINATE SYSTEM SOUTH ZONE GRID DISTANCE TO GROUND DISTANCE BY A SCALE FACTOR OF 1.0001265570. THE UNIT OF DISTANCE IS THE INTERNATIONAL FOOT.
- 3) THIS SURVEY WAS COMPLETED FOR ALLO TOWERS.



ORIENTATION OF THIS BEARING SYSTEM IS BASED ON THE NORTH DAKOTA STATE PLANE COORDINATE SYSTEM SOUTH ZONE NAD83 (2011)

● = DENOTES FOUND SECTION CORNER MONUMENT

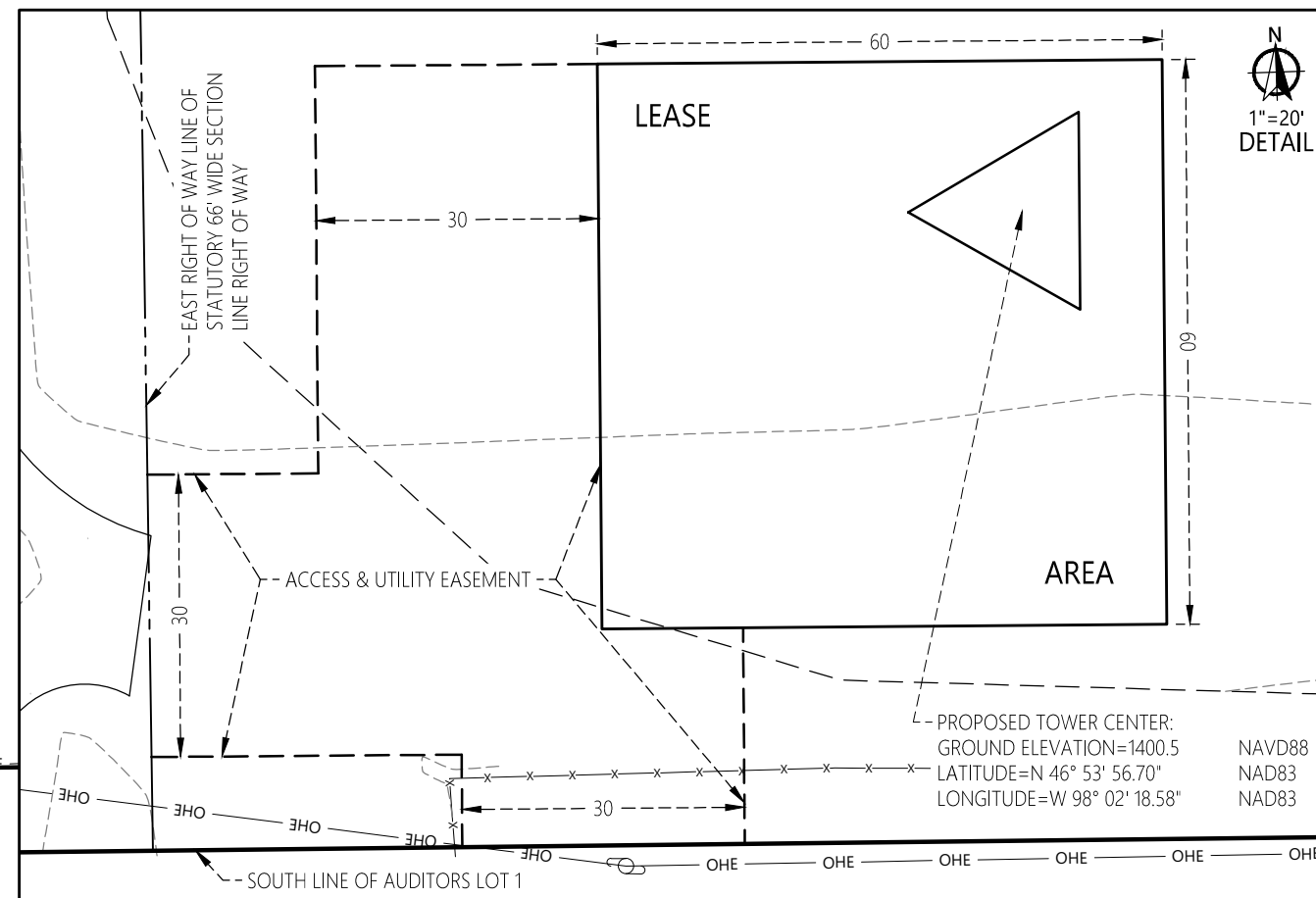
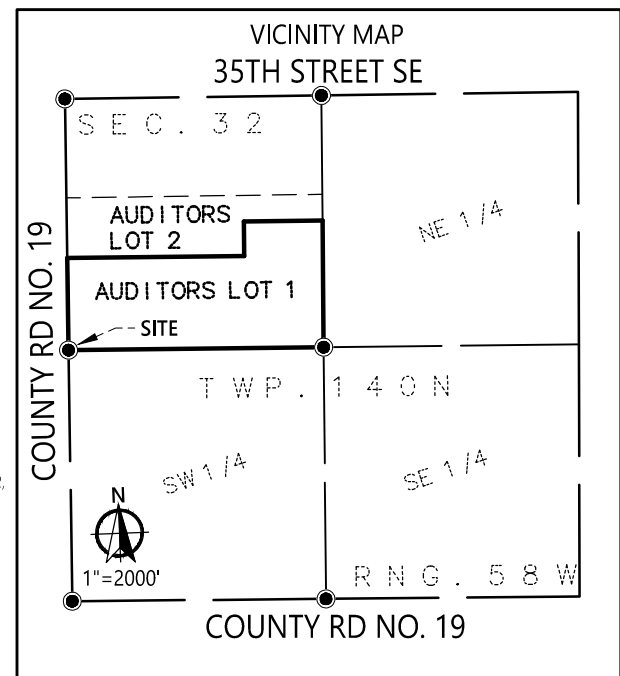

SITE NUMBER:
SRND240019
SITE NAME:
SIERRA
BARNES COUNTY, NORTH DAKOTA



DRAWN BY:
NTG
CHECKED BY:
CDJ

DATE	REVISIONS

PREPARED FOR: ALLO TOWERS
PROJECT #: 2025-10867
I HEREBY CERTIFY THAT THIS DOCUMENT WAS PREPARED BY ME OR UNDER MY DIRECT SUPERVISION AND THAT I AM A DULY LICENSED LAND SURVEYOR UNDER THE LAWS OF THE STATE OF NORTH DAKOTA.
PRELIMINARY
CHRISTOPHER D. JORDHEIM LIC. NO.: 5773 **DATE:** 8/7/2025

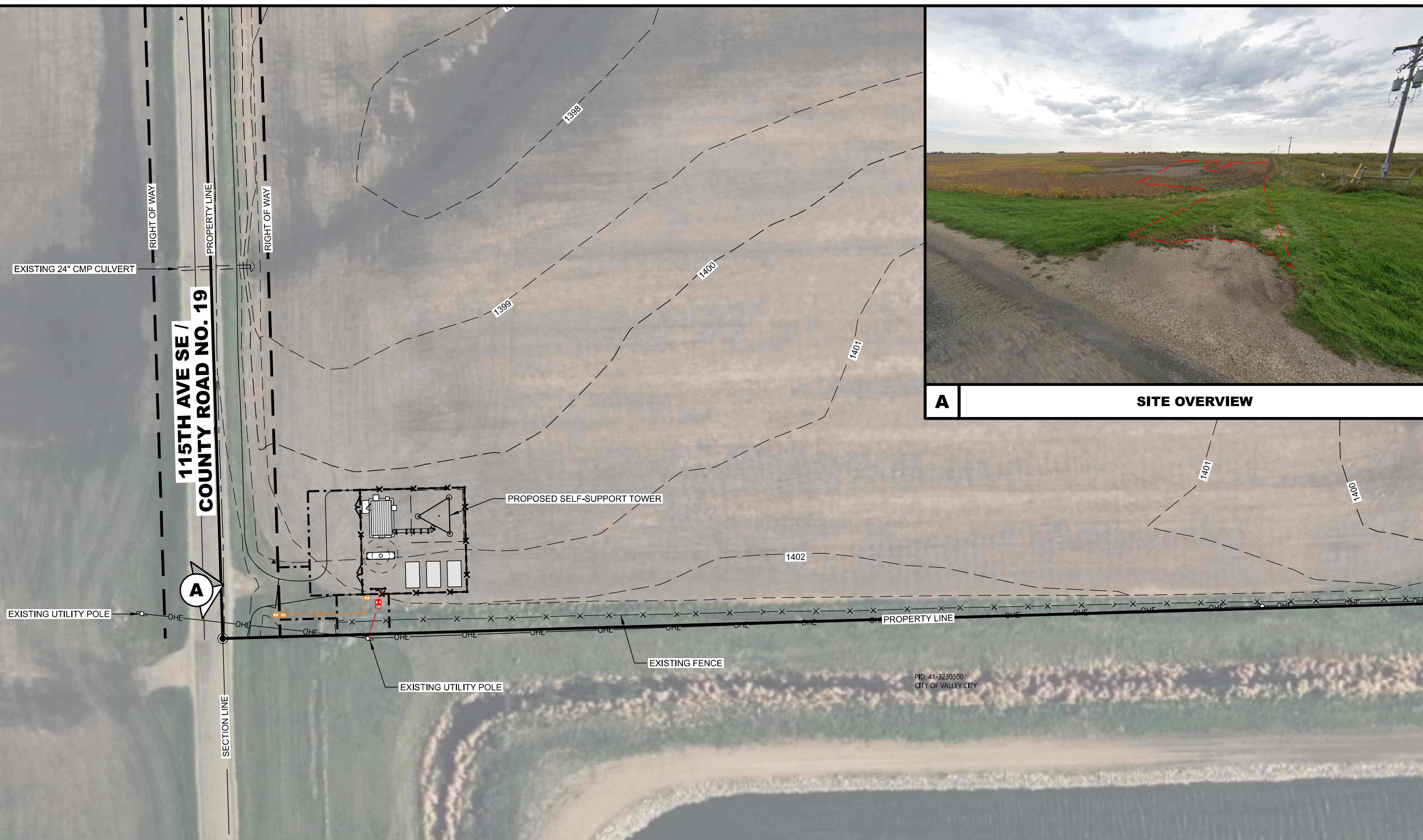

A SITE OVERVIEW

CONSULTANT:
Edge
Consulting Engineers, Inc.
2101 HIGHWAY 13 W
BURNSVILLE, MN 55337
608.644.1449 VOICE
608.644.1549 FAX
www.edgeconsult.com

CLIENT:
Allo Towers
151 KALMUS DR, SUITE E-201
COSTA MESA, CA 92626
949.749.1994 VOICE
www.allotowers.com

ENGINEER SEAL:
PRELIMINARY - NOT FOR CONSTRUCTION

I HEREBY CERTIFY THAT THIS PLAN SET WAS PREPARED BY ME OR UNDER MY DIRECT SUPERVISION OTHER THAN THE EXCEPTIONS NOTED IN THE SHEET INDEX, AND THAT I AM A DULY LICENSED PROFESSIONAL ENGINEER UNDER THE LAWS OF THE STATE OF NORTH DAKOTA.

OVERALL SITE PLAN
SIERRA (ND240019)
VALLEY CITY, NORTH DAKOTA

SUBMITTAL:

INT.	DATE:	DESCRIPTION:
TJT	09/16/25	REV A

CHECKED BY	OGD
PLOT DATE	9/16/2025
PROJECT NUMBER	44155
SET TYPE	PRELIM
SHEET NUMBER	C-101

LEGEND: (THIS SHEET)

OVERHEAD ELECTRIC	— OHE — OHE — OHE —
UNDERGROUND ELECTRIC	— E — E — E —
UNDERGROUND FIBER OPTIC	— FO — FO — FO —
RIGHT OF WAY	— — — — —
PROPERTY LINE	— — — — —
EASEMENT	- - - - -
CHAIN-LINK FENCE	- x - x - x - x - x -
TRANSFORMER	

PROJECT INFO:

PROJECT TYPE:	SELF-SUPPORT TOWER DEVELOPMENT HEIGHT: 194' ZONING HEIGHT: 250'
LEASE AREA:	60' x 60'
COMPOUND AREA:	60' x 60'
TOWER CENTER:	LAT: 46° 53' 56.70" N LONG: 98° 02' 18.58" W ELEV: 1400.5'
A.G.L. = ABOVE GROUND LEVEL	

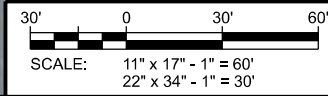

L:\441004\44155\Design\CAD\CD\IP\Set\C-101.dgn



CONSULTANT:
Edge
 Consulting Engineers, Inc.
 2101 HIGHWAY 13 W
 BURNSVILLE, MN 55337
 608.644.1449 VOICE
 608.644.1549 FAX
 www.edgeconsult.com

CLIENT:
Allo Towers
 151 KALMUS DR., SUITE E-201
 COSTA MESA, CA 92626
 949.749.1994 VOICE
 www.allotowers.com

ENGINEER SEAL:
NOT FOR CONSTRUCTION

I HEREBY CERTIFY THAT THIS PLAN SET WAS PREPARED BY ME OR UNDER MY DIRECT SUPERVISION OTHER THAN THE EXCEPTIONS NOTED IN THE SHEET INDEX, AND THAT I AM A DULY LICENSED PROFESSIONAL ENGINEER UNDER THE LAWS OF THE STATE OF NORTH DAKOTA.

SITE PLAN
SIERRA (ND240019)
VALLEY CITY, NORTH DAKOTA

SUBMITTAL:

INT.	DATE:	DESCRIPTION:
TJT	09/16/25	REV A

CHECKED BY:	OGD
PLOT DATE:	9/16/2025
PROJECT NUMBER:	44155
SET TYPE:	PRELIM
SHEET NUMBER:	C-102

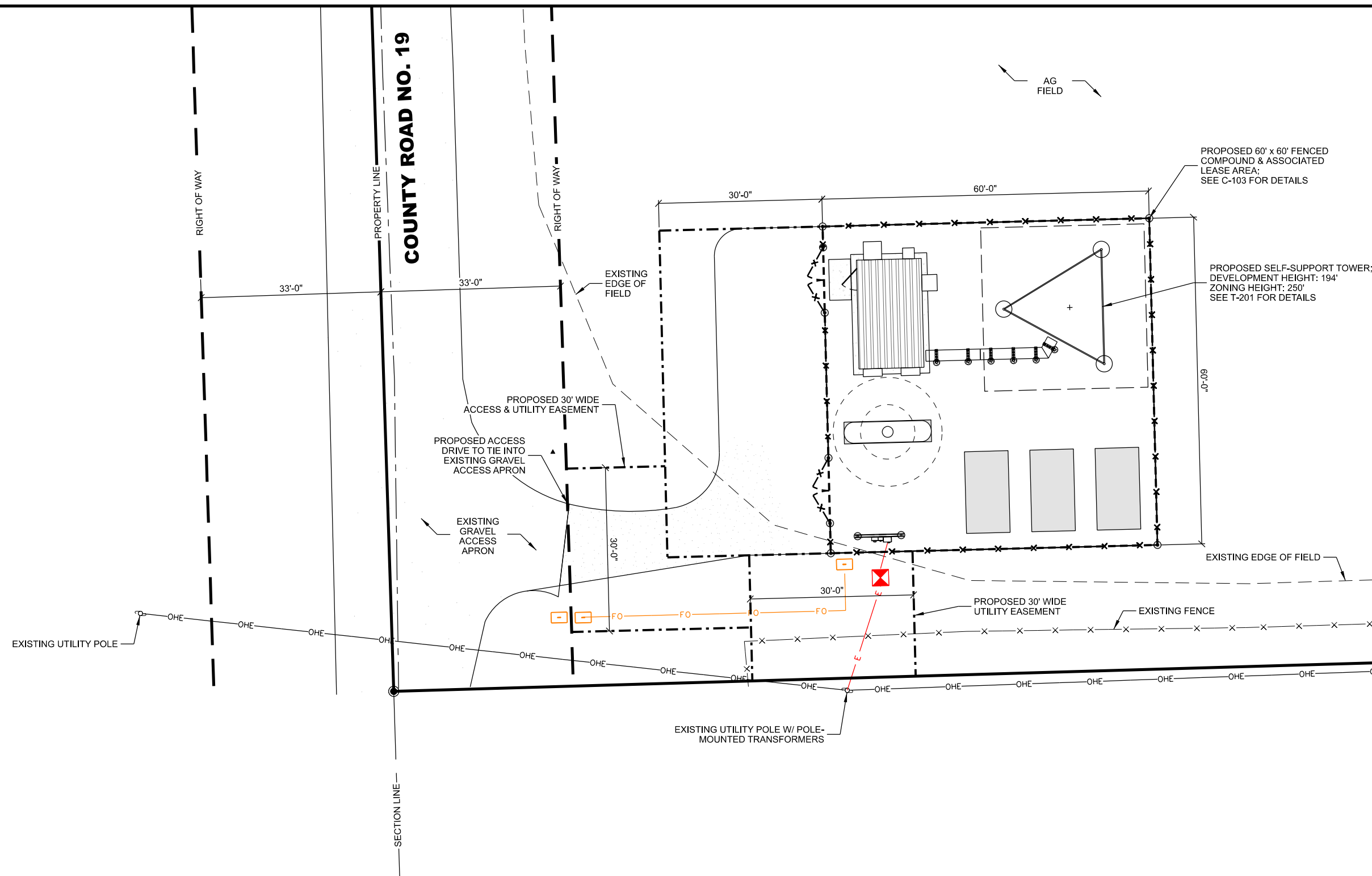

LEGEND: (THIS SHEET)

OVERHEAD ELECTRIC	— OHE — OHE — OHE —
UNDERGROUND ELECTRIC	— E — E — E —
UNDERGROUND FIBER OPTIC	— FO — FO — FO —
RIGHT OF WAY	— — — — —
PROPERTY LINE	— — — — —
EASEMENT	- - - - -
CHAIN-LINK FENCE	- x - x - x - x - x -
TRANSFORMER	

PROJECT INFO:

PROJECT TYPE:	SELF-SUPPORT TOWER DEVELOPMENT HEIGHT: 194' ZONING HEIGHT: 250'
LEASE AREA:	60' x 60'
COMPOUND AREA:	60' x 60'
TOWER CENTER:	LAT: 46° 53' 56.70" N LONG: 98° 02' 18.58" W ELEV: 1400.5'
A.G.L. = ABOVE GROUND LEVEL	

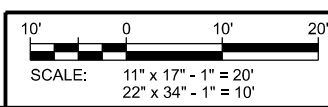

L:\441004\44155\Design\CAD\CD\Plot\C-102.dgn



CONSULTANT:
Edge
 Consulting Engineers, Inc.
 2101 HIGHWAY 13 W
 BURNSVILLE, MN 55337
 608.644.1449 VOICE
 608.644.1549 FAX
 www.edgeconsult.com

CLIENT:
Allo Towers
 151 KALMUS DR, SUITE E-201
 COSTA MESA, CA 92626
 949.749.1994 VOICE
 www.allotowers.com

ENGINEER SEAL:
PRELIMINARY - NOT FOR CONSTRUCTION

I HEREBY CERTIFY THAT THIS PLAN SET WAS PREPARED BY ME OR UNDER MY DIRECT SUPERVISION OTHER THAN THE EXCEPTIONS NOTED IN THE SHEET INDEX, AND THAT I AM A DULY LICENSED PROFESSIONAL ENGINEER UNDER THE LAWS OF THE STATE OF NORTH DAKOTA.

COMPOUND PLAN
 SIERRA (ND240019)
 VALLEY CITY, NORTH DAKOTA

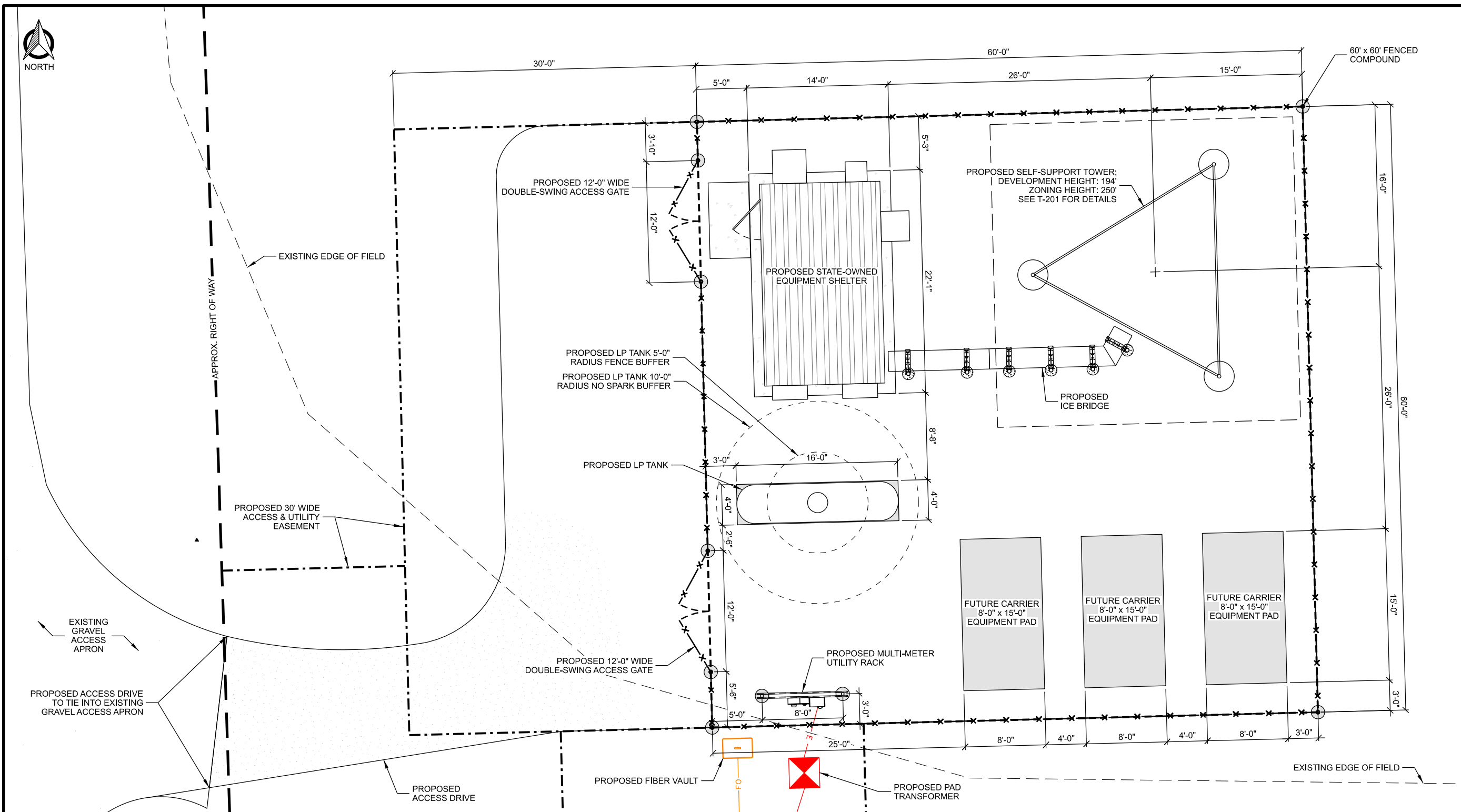

LEGEND: (THIS SHEET)

OVERHEAD ELECTRIC	— OHE — OHE — OHE —
UNDERGROUND ELECTRIC	— E — E — E —
UNDERGROUND FIBER OPTIC	— FO — FO — FO —
RIGHT OF WAY	— — — — —
PROPERTY LINE	— — — — —
EASEMENT	- - - - -
CHAIN-LINK FENCE	- x - x - x - x - x -
TRANSFORMER	

PROJECT INFO:

PROJECT TYPE: SELF-SUPPORT TOWER
 DEVELOPMENT HEIGHT: 194'
 ZONING HEIGHT: 250'

LEASE AREA: 60' x 60'

COMPOUND AREA: 60' x 60'

TOWER CENTER: LAT: 46° 53' 56.70" N
 LONG: 98° 02' 18.58" W
 ELEV: 1400.5'

A.G.L. = ABOVE GROUND LEVEL

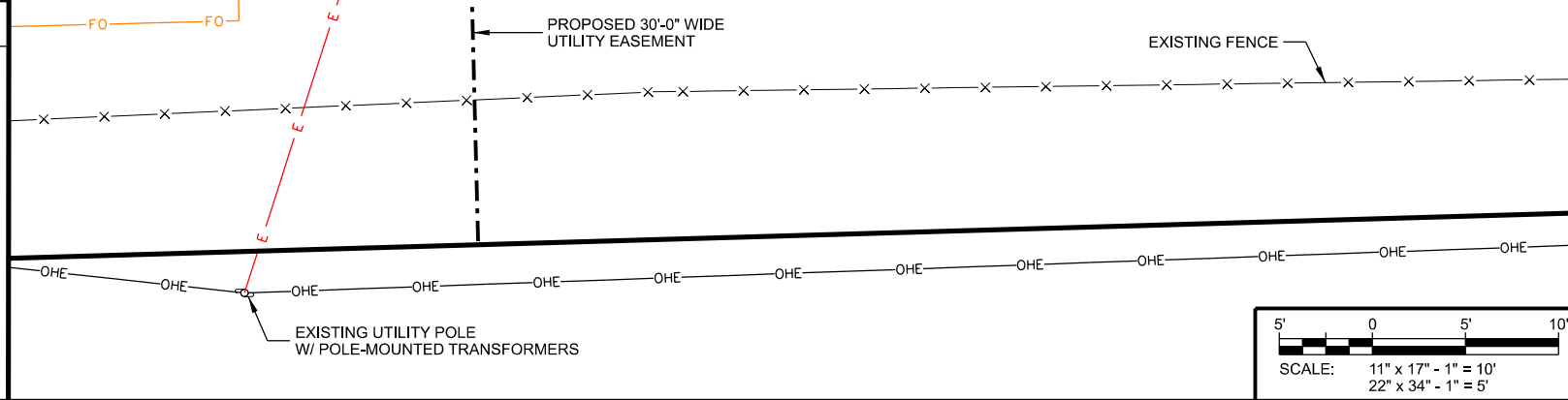

SUBMITTAL:

INT.	DATE:	DESCRIPTION:
TJT	09/16/25	REV A

CHECKED BY	OGD
PLOT DATE	9/16/2025
PROJECT NUMBER	44155
SET TYPE	PRELIM
SHEET NUMBER	C-103

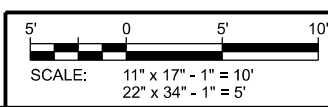

L:\44100\44155\Design\CAD\CD\Plot\CS-103.dgn

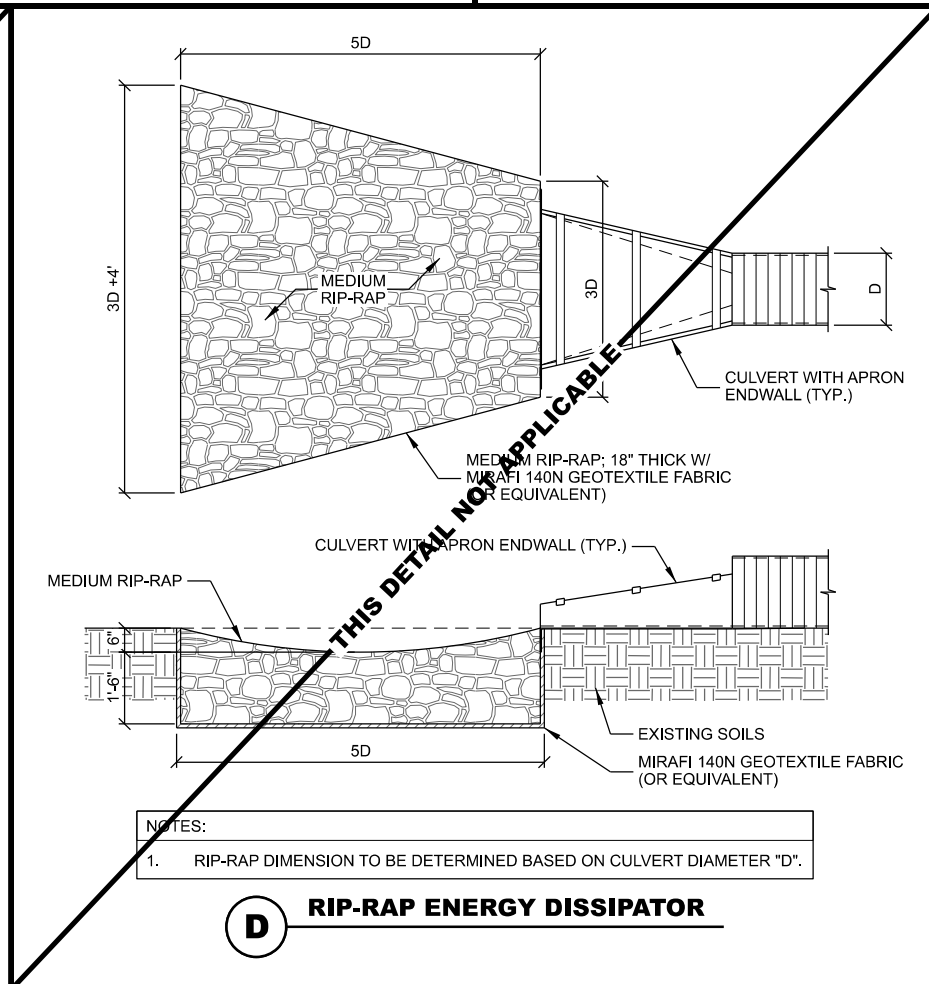
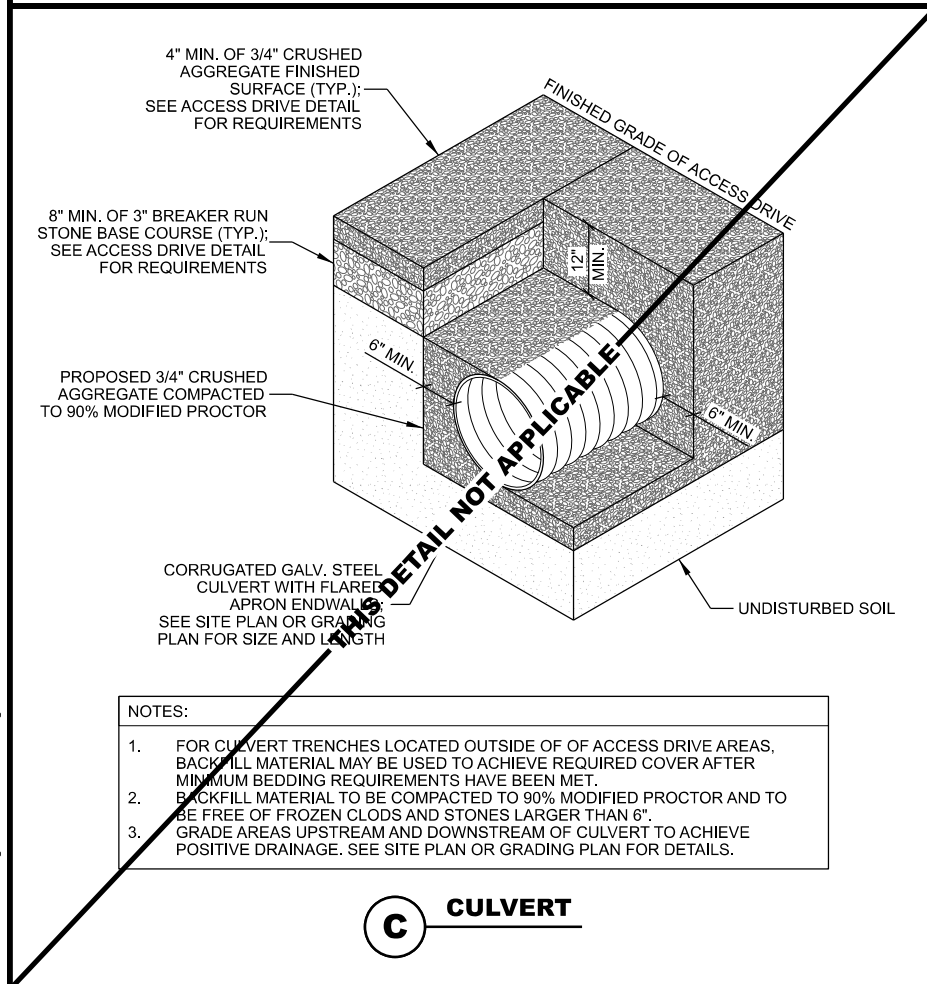
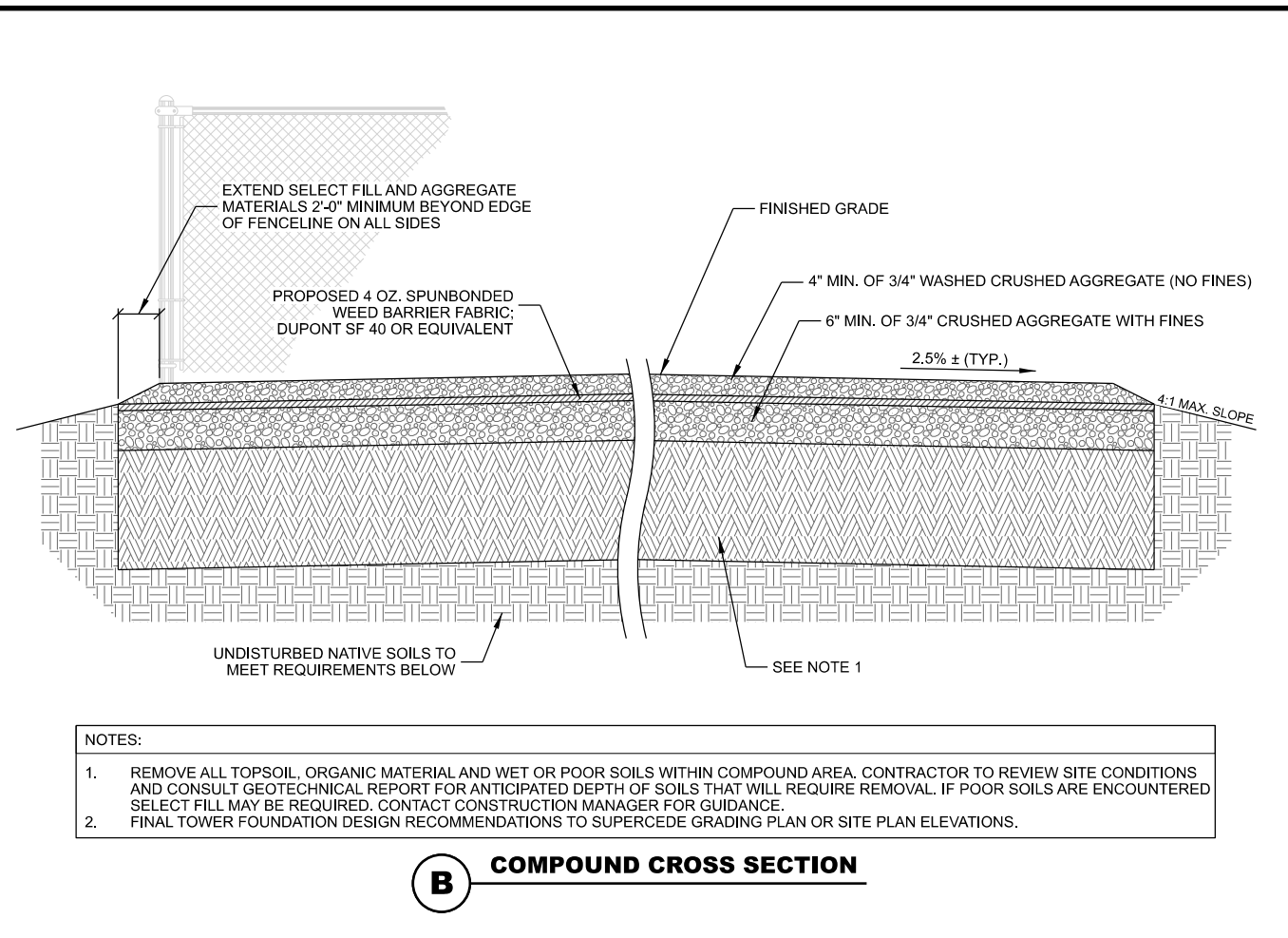
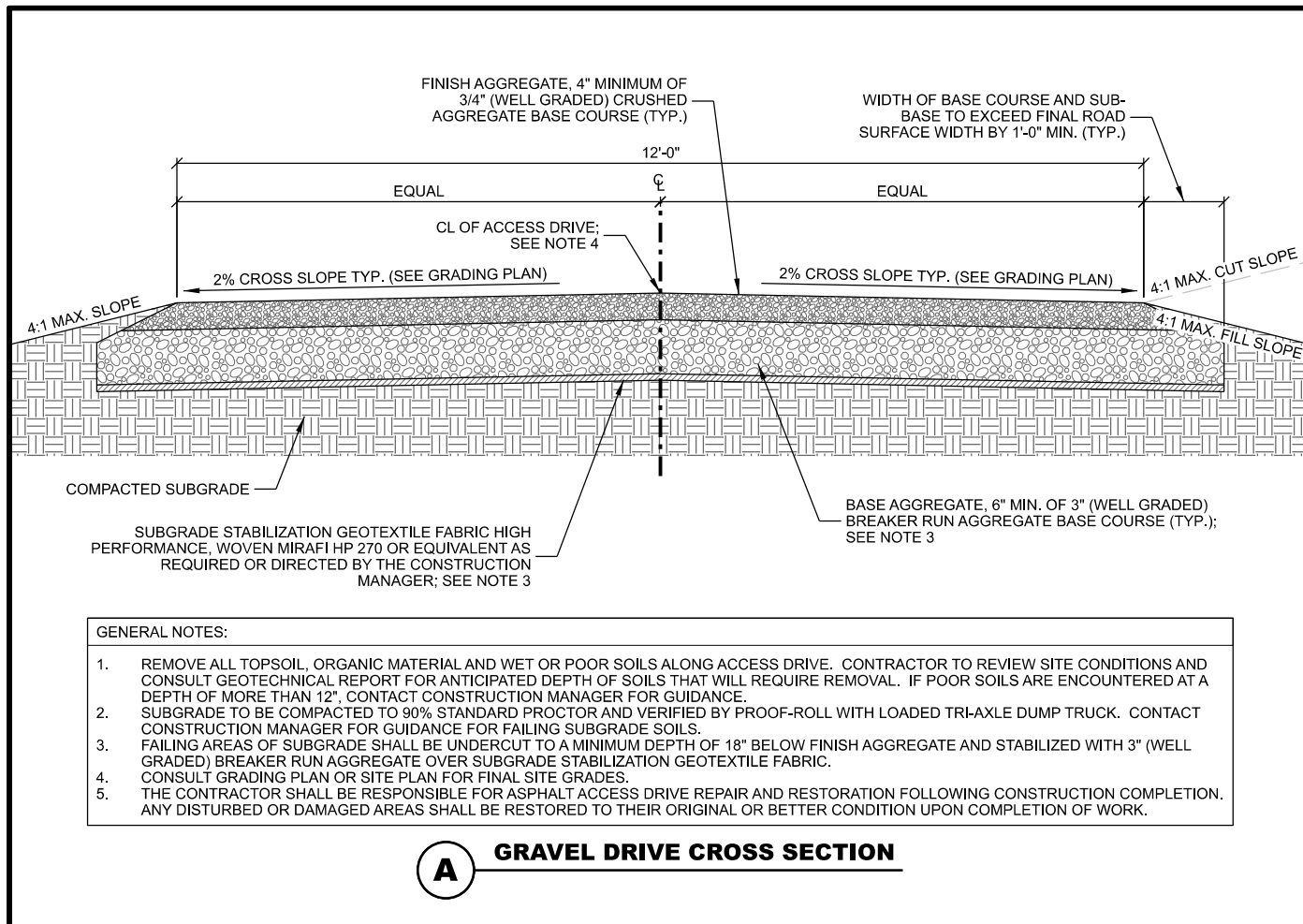

THIS SPACE INTENTIONALLY LEFT BLANK

CONSULTANT:

Edge
Consulting Engineers, Inc.
2101 HIGHWAY 13 W
BURNSVILLE, MN 55337
608.644.1449 VOICE
608.644.1549 FAX
www.edgeconsult.com

CLIENT:

Allo Towers
151 KALMUS DR., SUITE E-201
COSTA MESA, CA 92626
949.749.1994 VOICE
www.allotowers.com

ENGINEER SEAL:

PRELIMINARY - NOT FOR CONSTRUCTION

I HEREBY CERTIFY THAT THIS PLAN SET WAS PREPARED BY ME OR UNDER MY DIRECT SUPERVISION OTHER THAN THE EXCEPTIONS NOTED IN THE SHEET INDEX, AND THAT I AM A DULY LICENSED PROFESSIONAL ENGINEER UNDER THE LAWS OF THE STATE OF NORTH DAKOTA.

CONSTRUCTION DETAILS
SIERRA (ND240019)
VALLEY CITY, NORTH DAKOTA

SUBMITTAL:

INT.	DATE:	DESCRIPTION:
TJT	09/16/25	REV A

CHECKED BY:	OGD
PLOT DATE:	9/16/2025
PROJECT NUMBER:	44155
SET TYPE:	PRELIM
SHEET NUMBER:	C-501

L:\44100\44155\Design\CAD\CD\Plot\CS-501.dgn

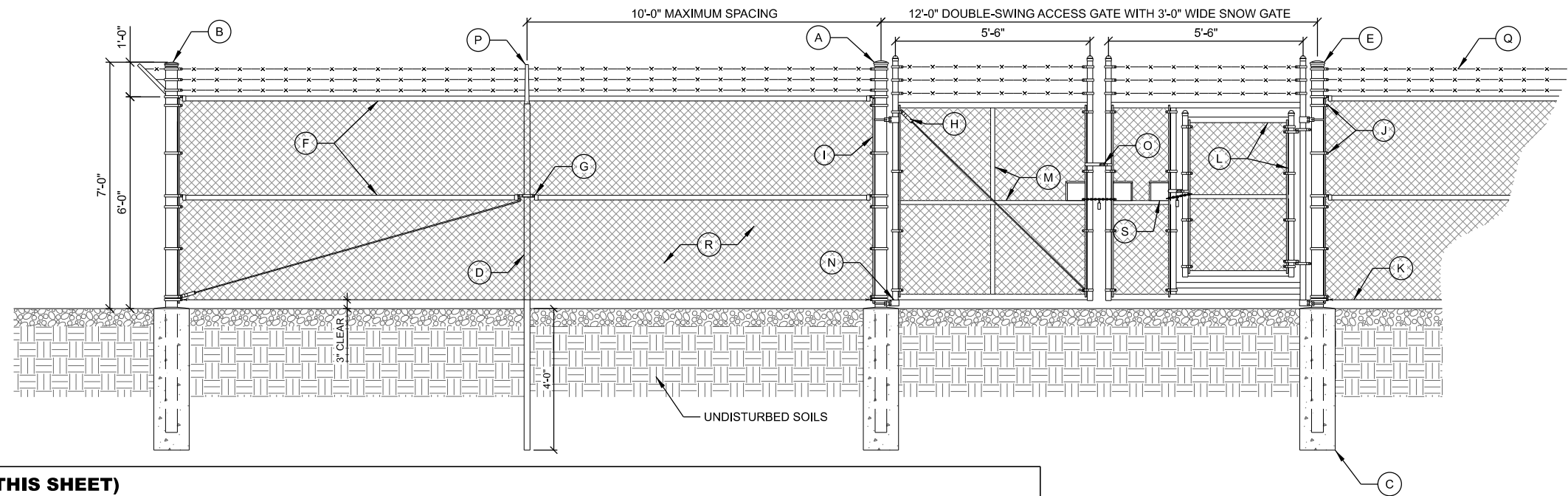

REFERENCE NOTES: (THIS SHEET)

- | | | |
|--|---|---|
| (A) 4" (4-1/2" O.D.) SCH. 40 GALV. STEEL GATE POST | (G) OFFSET BRACE RAIL ENDS FOR MID BRACE RAIL | (N) MALLEABLE BUTT HINGES (TYP.) |
| (B) 4" (4-1/2" O.D.) SCH 40 GALV. STEEL CORNER POST | (H) 5/16" O.D. TRUSS ROD WITH TRUSS TIGHTENER ASSEMBLY | (O) GATE LATCH; VERIFY REQUIREMENTS WITH FENCE MANUFACTURER |
| (C) CONCRETE PIER FOUNDATION AT CORNERS AND GATE; SEE DETAIL BELOW | (I) 3/16" x 3/4" STRETCHER BAR; TO EXTEND FULL HEIGHT OF FENCE FABRIC | (P) 45° BARB ARM FENCE POST CAP |
| (D) 2" (2-3/8" O.D.) SCH. 40 GALV. STEEL INTERMEDIARY LINE POSTS; LINE POSTS SHALL BE EQUALLY SPACED AT MAXIMUM 10'-0" O.C | (J) 3/4" TENSION BAND (TYP.). | (Q) (3) STRANDS OF 4 PT. GALV. BARB WIRE |
| (E) FENCE POST CAP (SIZE VARIES) | (K) TENSION WIRE | (R) #9 GAUGE GALV. CHAIN LINK FENCE FABRIC WITH TWISTED TOP SELVAGE AND KNUCKLED BOTTOM SELVAGE |
| (F) 1-1/4" (1.66" O.D.) TOP RAIL & MID BRACE RAIL PIPE | (L) 1-1/2" (1.9" O.D.) SCH. 40 GALV. STEEL FENCE GATE FRAME | (S) 6" x 6" HANDHOLE FOR CHAIN LOCK |
| | (M) 1-1/4" (1.66" O.D.) SCH. 40 GALV. STEEL HORIZONTAL AND VERTICAL GATE BRACES | |

A COMPOUND FENCE

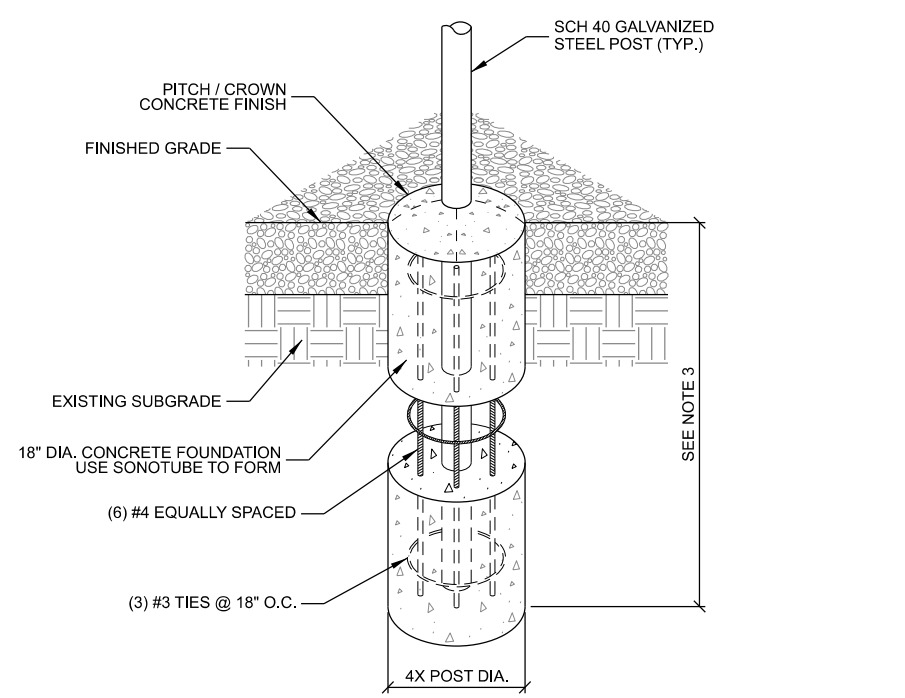

- NOTES:**
1. MAINTAIN 3" MINIMUM REBAR COVER WITH CONCRETE IN ALL DIRECTIONS.
 2. CONCRETE MIX TO BE 4,000 PSI @ 28 DAYS.
 3. FOUNDATION DEPTH TO EXCEED LOCAL FROST DEPTH, OR 48" MINIMUM.

B PIER FOUNDATION

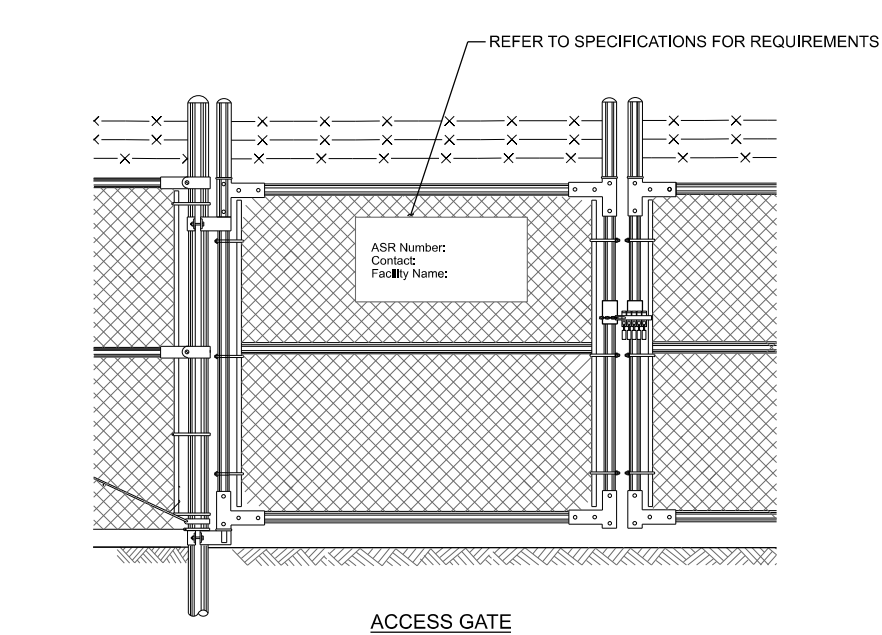

- GENERAL NOTES:**
1. THE ANTENNA STRUCTURE REGISTRATION NUMBER SHALL BE DISPLAYED PER 47 CFR 17.4 (g).
 2. THE ASR NUMBER SHALL BE POSTED ON THE PERIMETER FENCE OR ACCESS GATE SO THAT IT IS CONSPICUOUSLY VISIBLE AND LEGIBLE FROM THE PUBLICLY ACCESSIBLE AREA NEAREST THE BASE OF THE ANTENNA STRUCTURE ALONG A PUBLICLY ACCESSIBLE ROADWAY OR PATH.
 3. MATERIALS USED TO DISPLAY THE ANTENNA STRUCTURE REGISTRATION NUMBER MUST BE WEATHER-RESISTANT AND OF SUFFICIENT SIZE TO BE EASILY SEEN WHERE POSTED.

C ANTENNA STRUCTURE REGISTRATION (ASR) SIGNAGE

THIS SPACE INTENTIONALLY LEFT BLANK

CONSULTANT:
Edge
 Consulting Engineers, Inc.
 2101 HIGHWAY 13 W
 BURNSVILLE, MN 55337
 608.644.1449 VOICE
 608.644.1549 FAX
 www.edgeconsult.com

CLIENT:
Allo Towers
 151 KALMUS DR., SUITE E-201
 COSTA MESA, CA 92626
 949.749.1994 VOICE
 www.allotowers.com

ENGINEER SEAL:
PRELIMINARY - NOT FOR CONSTRUCTION

I HEREBY CERTIFY THAT THIS PLAN SET WAS PREPARED BY ME OR UNDER MY DIRECT SUPERVISION OTHER THAN THE EXCEPTIONS NOTED IN THE SHEET INDEX, AND THAT I AM A DULY LICENSED PROFESSIONAL ENGINEER UNDER THE LAWS OF THE STATE OF NORTH DAKOTA.

FENCE DETAILS
SIERRA (ND240019)
VALLEY CITY, NORTH DAKOTA

SUBMITTAL:		
INT.	DATE:	DESCRIPTION:
TJT	09/16/25	REV A

CHECKED BY:	OGD
PLOT DATE:	9/16/2025
PROJECT NUMBER:	44155
SET TYPE:	PRELIM
SHEET NUMBER:	C-502

L:\44100\44155\Design\CAD\CD\PIer\CC-502.dgn

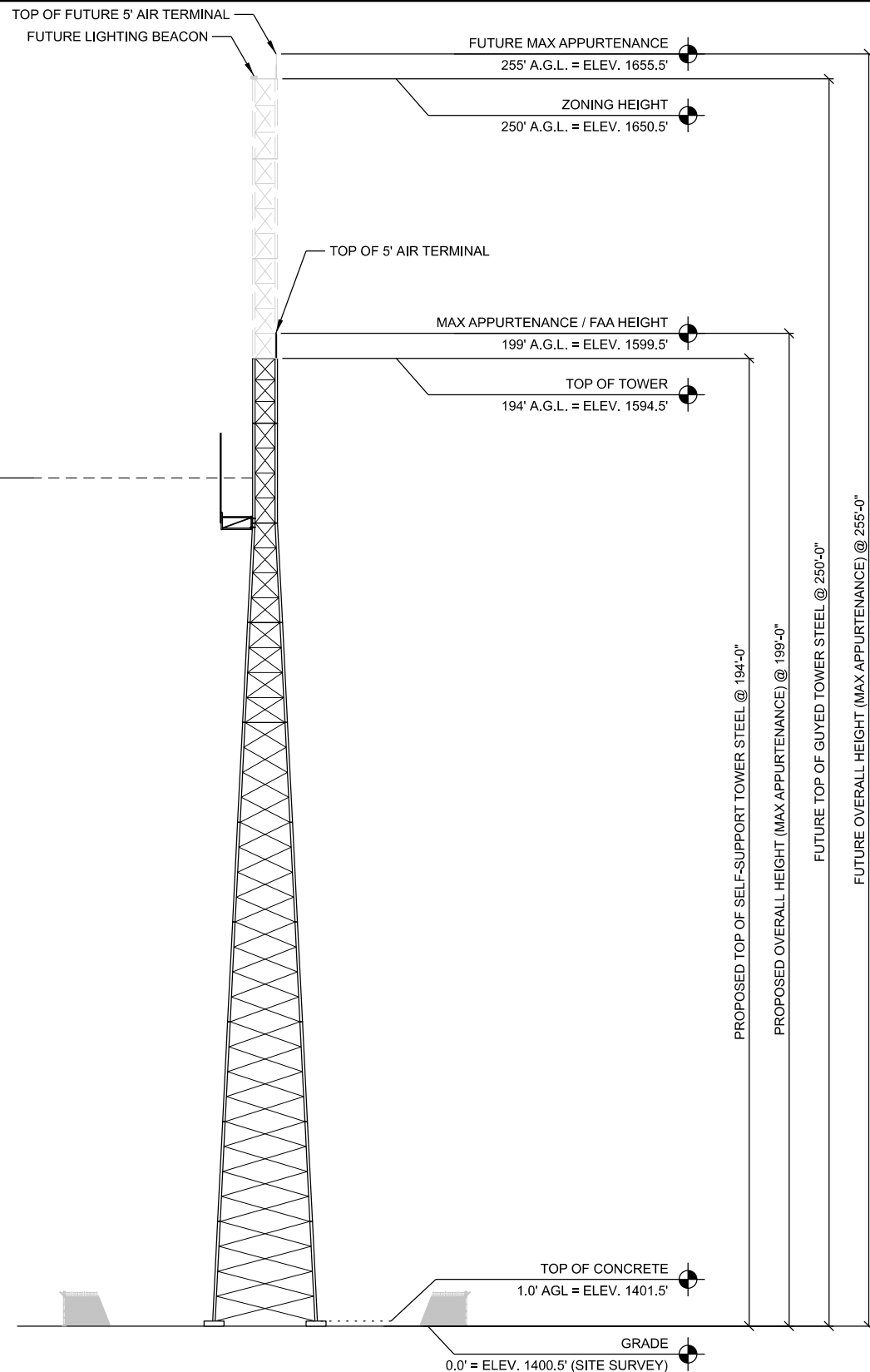

- NOTES:
1. ALL DIMENSIONS SHOWN ARE REFERENCED FROM ABOVE GROUND LEVEL (A.G.L.).
 2. ALL ANTENNAS, DISHES, MOUNTS, ICE SHIELDS AND LINES SHALL BE SUPPLIED AND INSTALLED BY OTHERS.
 3. AIR TERMINAL MOUNT TO BE BOLTED DIRECTLY TO TOWER STEEL. AIR TERMINAL TO BE BONDED TO AIR TERMINAL MOUNT.

A TOWER PROFILE (ELEVATION)

LEGEND:
 A.G.L. = ABOVE GROUND LEVEL
 TYP. = TYPICAL
 ELEV. = ELEVATION

CONSULTANT:
Edge
 Consulting Engineers, Inc.
 2101 HIGHWAY 13 W
 BURNSVILLE, MN 55337
 608.644.1449 VOICE
 608.644.1549 FAX
 www.edgeconsult.com

CLIENT:
Allo Towers
 151 KALMUS DR, SUITE E-201
 COSTA MESA, CA 92626
 949.749.1994 VOICE
 www.allotowers.com

ENGINEER SEAL:
PRELIMINARY - NOT FOR CONSTRUCTION

I HEREBY CERTIFY THAT THIS PLAN SET WAS PREPARED BY ME OR UNDER MY DIRECT SUPERVISION OTHER THAN THE EXCEPTIONS NOTED IN THE SHEET INDEX, AND THAT I AM A DULY LICENSED PROFESSIONAL ENGINEER UNDER THE LAWS OF THE STATE OF NORTH DAKOTA.

TOWER LOADING / ELEVATION
 SIERRA (ND240019)
 VALLEY CITY, NORTH DAKOTA

SUBMITTAL:		
INT.	DATE:	DESCRIPTION:
TJT	09/16/25	REV A

CHECKED BY:	OGD
PLOT DATE:	9/16/2025
PROJECT NUMBER:	44155
SET TYPE:	PRELIM
SHEET NUMBER:	T-201

L:\44100\44155\Design\CAD\CD\IP\klt\T-201.dgn

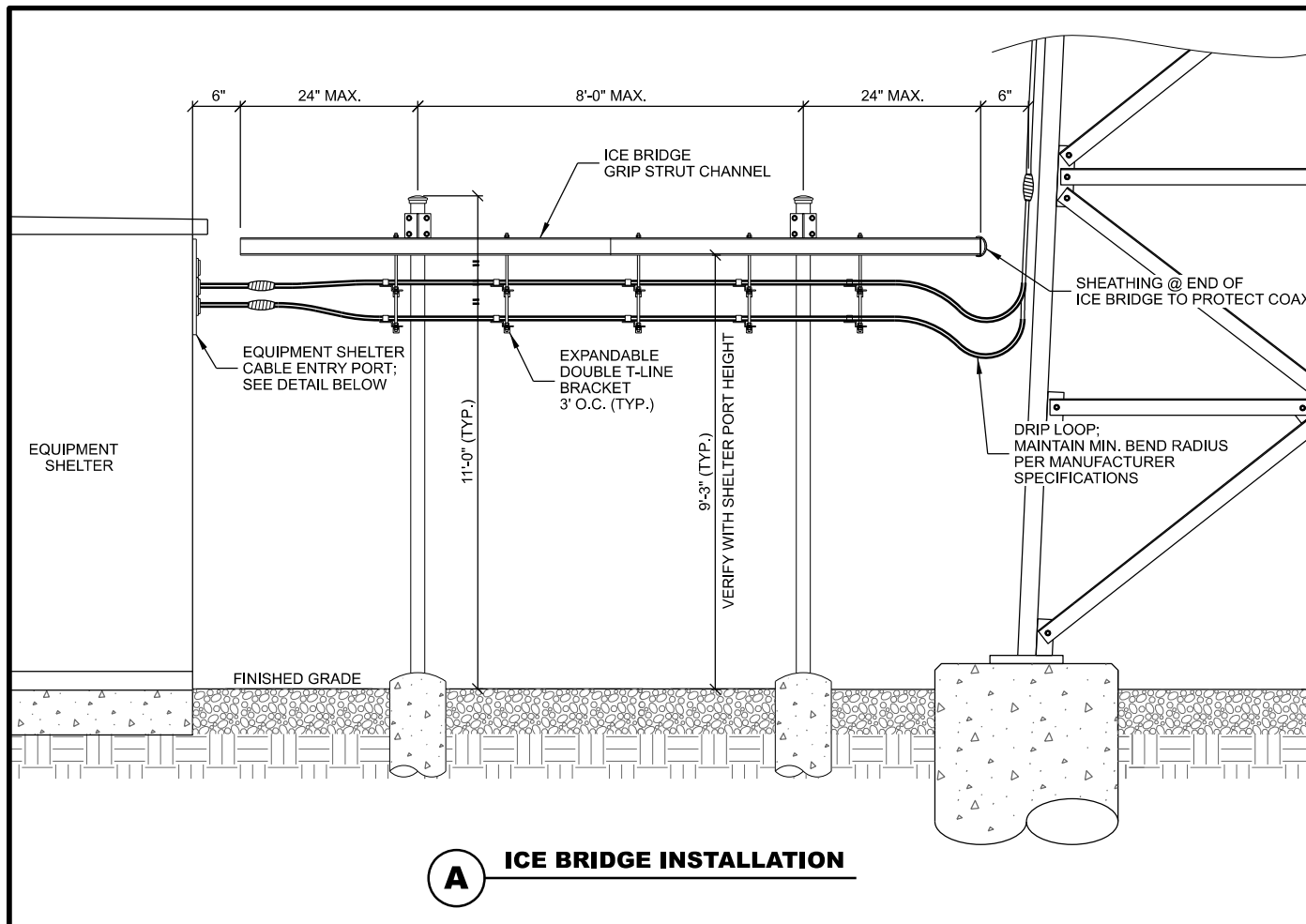

A ICE BRIDGE INSTALLATION

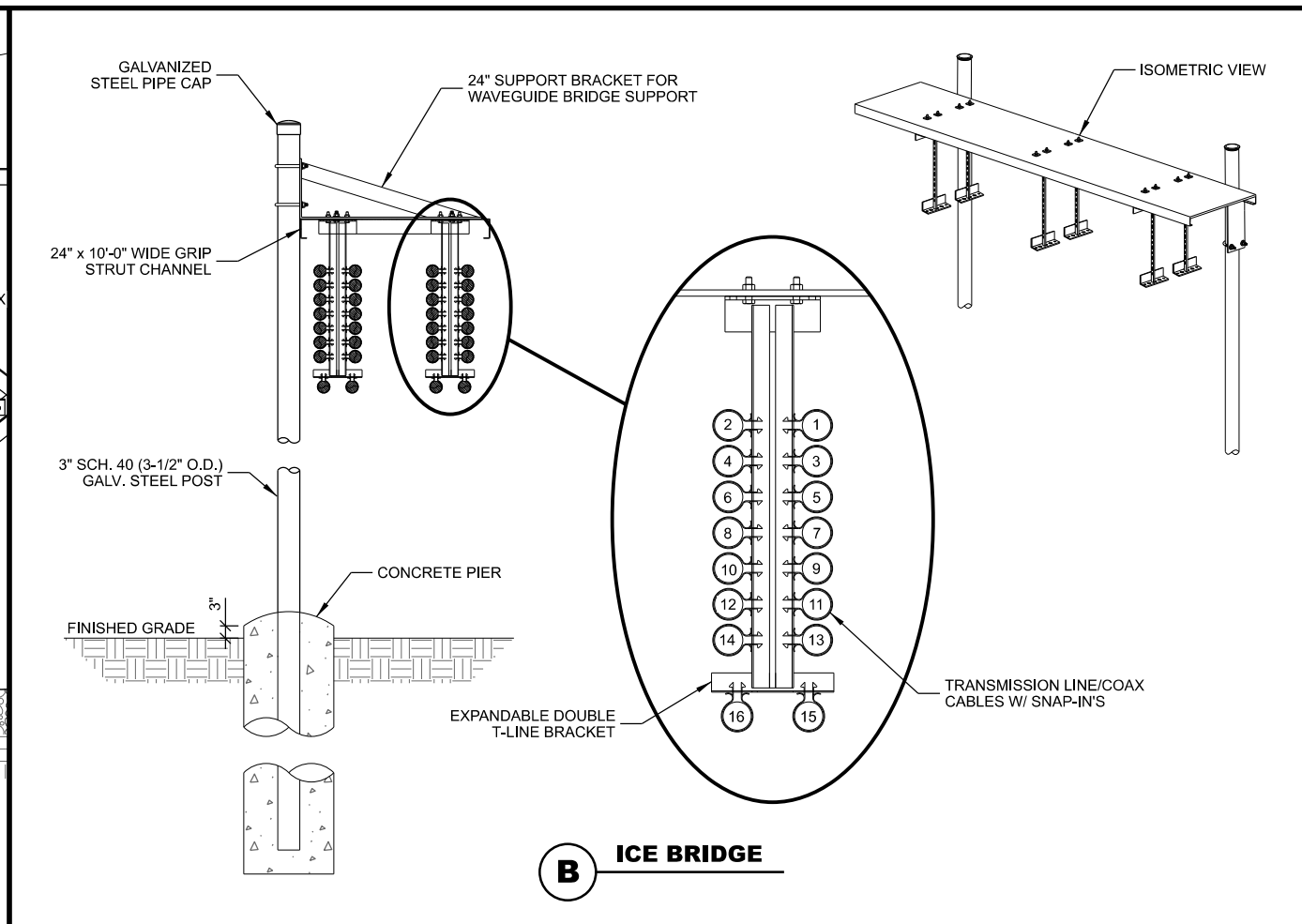

B ICE BRIDGE

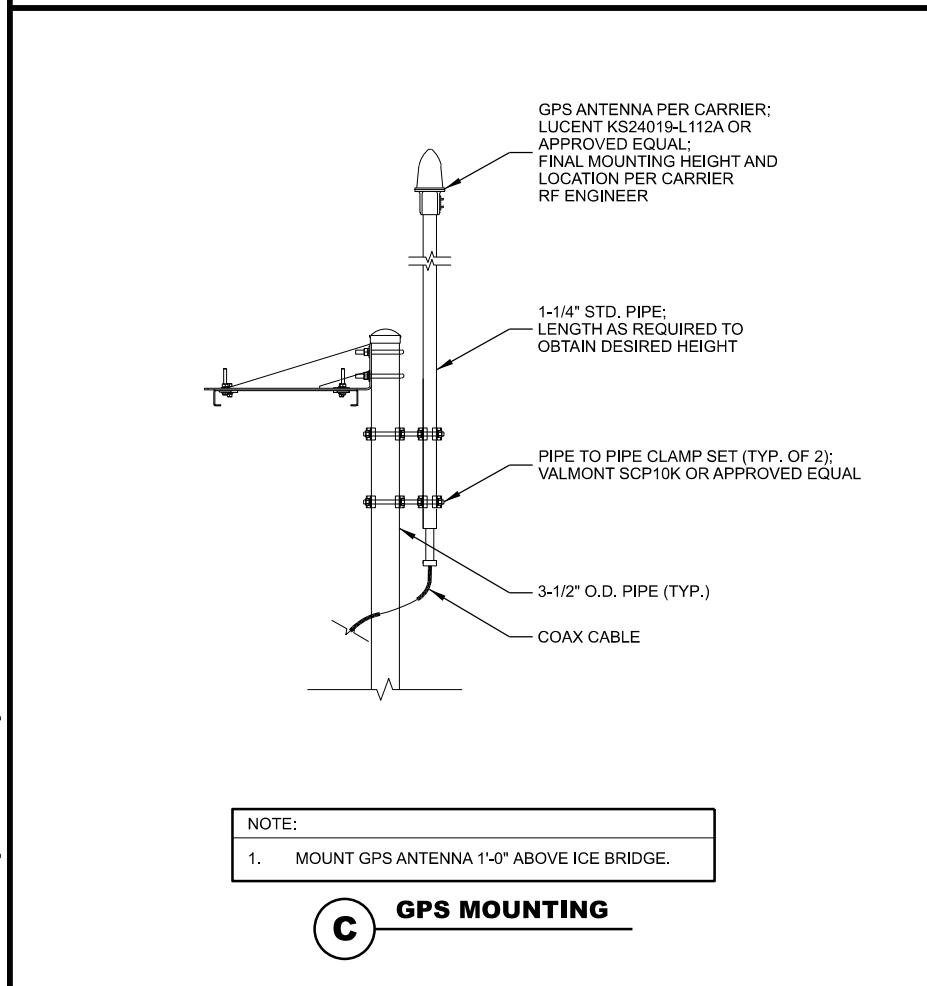

C GPS MOUNTING

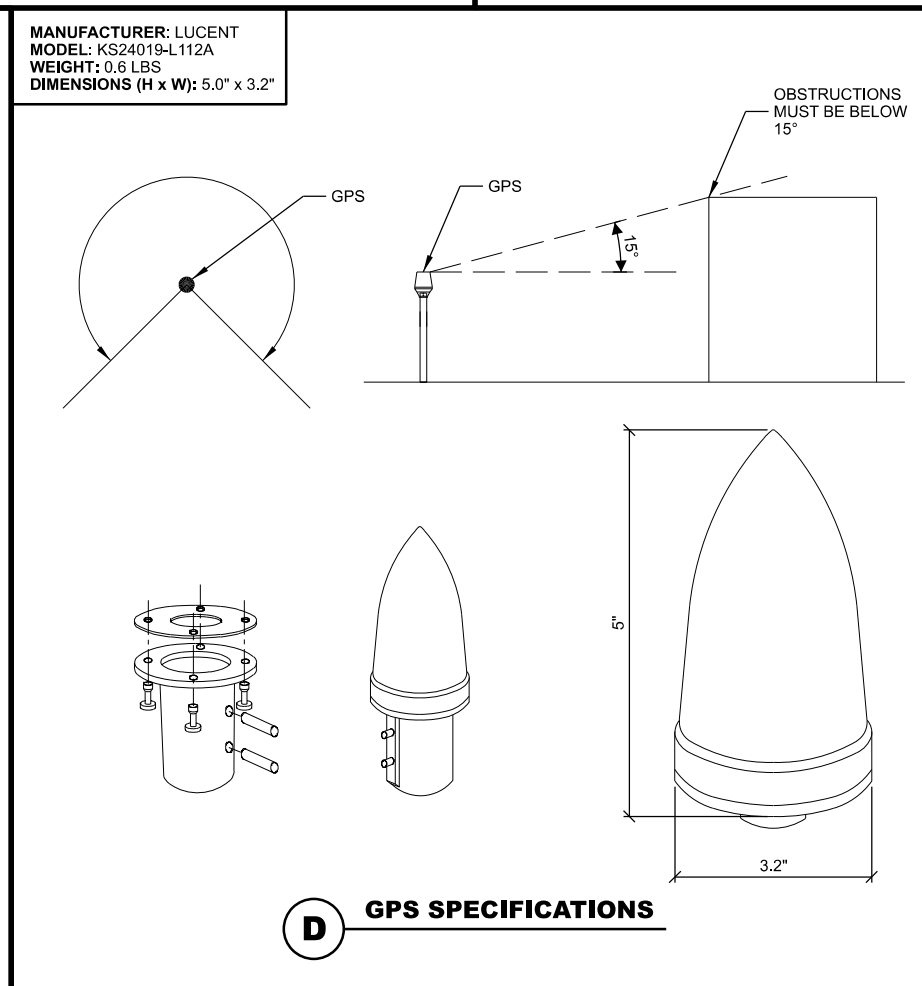

D GPS SPECIFICATIONS

- ICE BRIDGE NOTES : (THIS SHEET)**
- FOR COMPONENTS AS SHOWN IN STANDARD DETAILS, MAXIMUM ALLOWABLE SPAN BETWEEN SUPPORTS ON A CONTINUOUS SINGLE SECTION OF BRIDGE CHANNEL SHALL BE 8' FOR A 10' SECTION.
 - SPLICES IN SECTIONS OF BRIDGE CHANNEL SHALL BE INSTALLED AT SUPPORTS, WHERE POSSIBLE, OR AT MOST 2' FROM A SUPPORT.
 - FREE ENDS OF ICE BRIDGE CHANNELS SHALL NOT EXCEED A CANTILEVER DISTANCE OF 2' FROM A SUPPORT.
 - CUT BRIDGE CHANNEL SECTIONS SHALL HAVE RAW EDGES TREATED WITH COLD GALVANIZING SPRAY.
 - DEVIATIONS FROM STANDARDS FOR COMPONENT INSTALLATIONS ARE PERMITTED WITH MANUFACTURER'S AND ENGINEER'S APPROVAL.
 - DEVIATIONS FROM ICE BRIDGE FOUNDATIONS SHOWN ON SITE SPECIFIC DRAWINGS OR STANDARD DETAILS REQUIRE ENGINEERING APPROVAL.
 - INSTALL PROTECTIVE SHEATHING AT TOWER END OF ICE BRIDGE TO PROTECT CABLING.

CONSULTANT:
Edge
 Consulting Engineers, Inc.
 2101 HIGHWAY 13 W
 BURNSVILLE, MN 55337
 608.644.1449 VOICE
 608.644.1549 FAX
 www.edgeconsult.com

CLIENT:
Allo Towers
 151 KALMUS DR., SUITE E-201
 COSTA MESA, CA 92626
 949.749.1994 VOICE
 www.allotowers.com

ENGINEER SEAL:
PRELIMINARY - NOT FOR CONSTRUCTION

I HEREBY CERTIFY THAT THIS PLAN SET WAS PREPARED BY ME OR UNDER MY DIRECT SUPERVISION OTHER THAN THE EXCEPTIONS NOTED IN THE SHEET INDEX, AND THAT I AM A DULY LICENSED PROFESSIONAL ENGINEER UNDER THE LAWS OF THE STATE OF NORTH DAKOTA.

ICE BRIDGE DETAILS
SIERRA (ND240019)
VALLEY CITY, NORTH DAKOTA









SUBMITTAL:

INT.	DATE:	DESCRIPTION:
TJT	09/16/25	REV A

CHECKED BY	OGD
PLOT DATE	9/16/2025
PROJECT NUMBER	44155
SET TYPE	PRELIM
SHEET NUMBER	T-501

L:\44100\44155\Design\CAD\CD\IP\T-501.dgn

GROUNDING LEGEND: (THIS SHEET)

-  GROUND TEST WELL, SEE E-502 FOR DETAILS
-  COPPER CLAD GROUND ROD, (5/8" DIA. x 10' LONG)
SPACE @ 2X GROUND ROD LENGTH (20' O.C. MAX., 6' MIN.)
-  COPPER PLATE, (18" x 18" x 0.032" THK)
SPACE @ 2X GROUND ROD LENGTH (20' O.C. MAX., 6' MIN.)
-  EXOTHERMIC OR UL RATED IRREVERSIBLE CONNECTION
(CADWELD OR HYGROUND)
-  MECHANICAL CONNECTION
(BURNDY 2-HOLE LUG OR APPROVED EQUAL)
-  #2 AWG BARE SOLID TINNED COPPER CONDUCTOR
IN STANDARD GROUND TRENCH, SEE E-502 FOR DETAILS
-  #2/0 AWG BARE STRANDED TINNED COPPER CONDUCTOR
IN STANDARD GROUND TRENCH, SEE E-502 FOR DETAILS
-  #2 AWG BARE SOLID TINNED COPPER CONDUCTOR
IN ENHANCED GROUND TRENCH, SEE E-502 FOR DETAILS



KEYNOTES: (THIS SHEET)

- A. TOWER GROUND RING, MAINTAIN 2' SEPARATION FROM TOWER FOUNDATION
- B. SHELTER GROUND RING, MAINTAIN 2' SEPARATION FROM SHELTER FOUNDATION
- C. TOWER GROUND BAR, (2) LEADS TO TOWER GROUND RING & (1) TO TOWER STEEL
- D. TOWER STEEL GROUND, (1) PER LEG REQ'D. EXOTHERMIC WELD TO LEG GROUND TAB
- E. TOWER FOUNDATION GROUND, SEE E-502 FOR DETAILS
- F. ICE BRIDGE/UTILITY POST GROUND, SEE E-501 FOR DETAILS
- G. FENCE CORNER POST GROUND, SEE E-502 FOR DETAILS
- H. FENCE GATE GROUND, SEE E-502 FOR DETAILS
- I. GROUND LP TANK, EACH LEG
- J. A/C METER BOX GROUND
- K. EXTERIOR SHELTER GROUND BAR, (2) LEADS TO SHELTER GROUND RING
- L. SHELTER GROUND RING TO TOWER GROUND RING, (2) LEADS
- M. SHELTER EXTERIOR AC UNIT GROUND
- N. SHELTER METAL BOX / HOOD VENT GROUND
- O. SHELTER FOUNDATION GROUND, SEE E-502 FOR DETAILS
- P. SHELTER ANCHOR TAB GROUND. CLOSEST TAB TO RF ENTRY PORT (1 REQ'D)
- Q. SHELTER DOOR FRAME GROUND

GENERAL NOTES: (THIS SHEET)

1. ALL EXTERIOR GROUNDING SHALL MEET OR EXCEED THE CURRENT HARRIS SITE GROUNDING AND LIGHTNING PROTECTION GUIDELINES. REFER TO INSTALLATION MANUAL AE/LZT 123 4618/1 REV F (JUNE 2017).
2. THE GROUNDING SYSTEM & CONDUCTORS SHALL BE INSPECTED BY THE ENGINEER PRIOR TO BACK FILLING. SYSTEM SHALL PROVIDE 3 OHM OR LESS RESISTANCE UPON COMPLETION.
3. ALL NON-INSULATED GROUND LEADS EXTENDING ABOVE GROUND LEVEL SHALL BE ENCASED IN 1/2" PVC & SEALED WITH SILICONE.
4. GROUND RINGS & TOP OF RODS SHALL BE INSTALLED AT 30" BELOW FINISHED GRADE. (SEE DETAIL A/E-501)
5. INSTALL 18"x18" COPPER PLATES IN LIEU OF GROUND RODS WHEN INSTALLING OVER TOWER FOUNDATION OR WHERE DRIVING GROUND RODS IS NOT FEASIBLE. REFER TO GEOTECH REPORT FOR SOIL CONDITIONS.
6. ALL MECHANICAL CONNECTIONS SHALL INCLUDE ANTI-OXIDANT COMPOUND BETWEEN LUG & CONNECTION POINT. USE COPPER ANTI-OXIDANT FOR COPPER TO COPPER CONNECTION
7. ALL ABOVE GRADE CADWELD CONNECTIONS (TO GALVANIZED ITEMS) SHALL BE SPRAYED WITH COLD GALVANIZING COMPOUND TO PREVENT CORROSION.

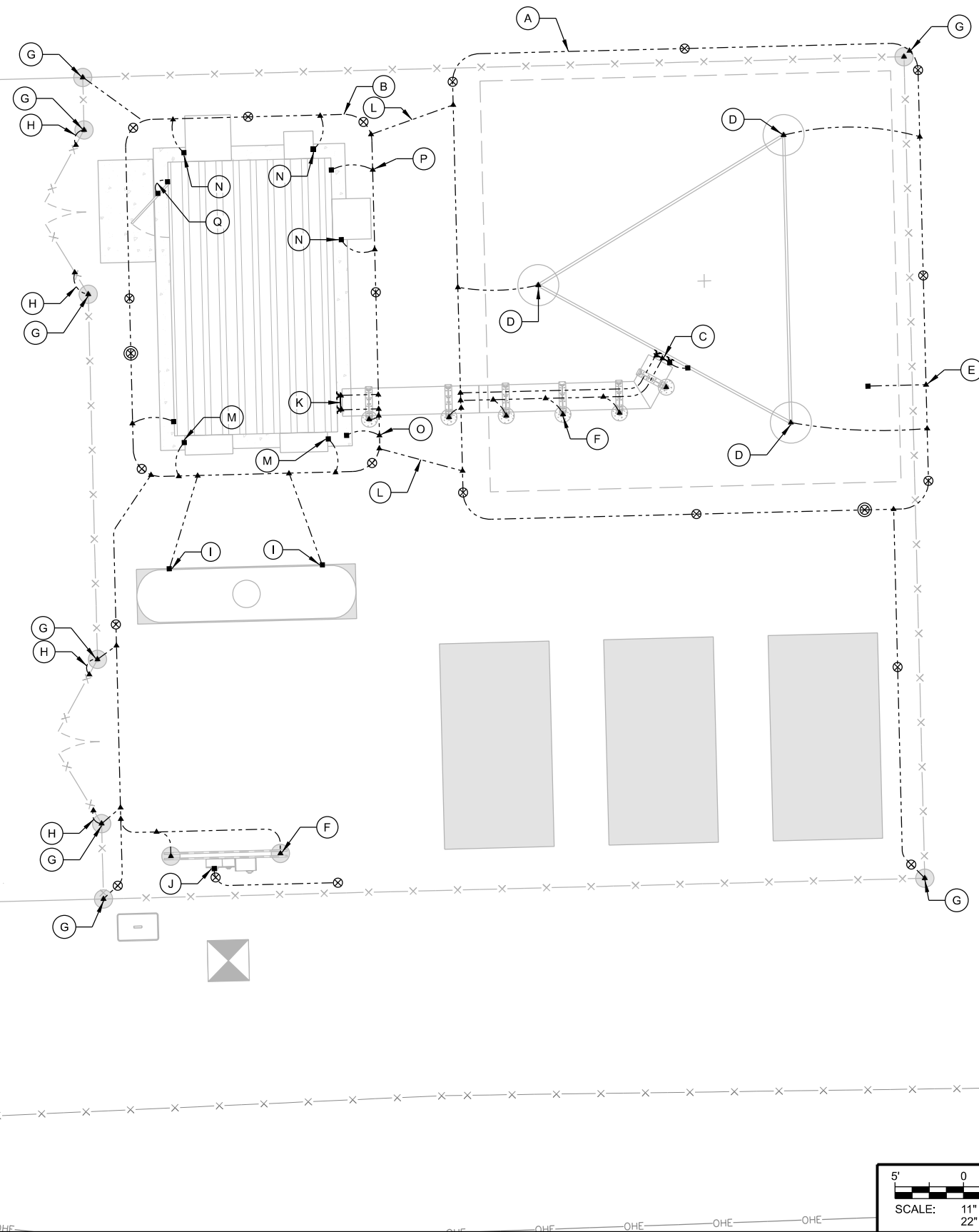

CONSULTANT:

 2101 HIGHWAY 13 W
 BURNSVILLE, MN 55337
 608.644.1449 VOICE
 608.644.1549 FAX
 www.edgeconsult.com

CLIENT:

 151 KALMUS DR., SUITE E-201
 COSTA MESA, CA 92626
 949.749.1994 VOICE
 www.allotowers.com

ENGINEER SEAL:

PRELIMINARY - NOT FOR CONSTRUCTION

I HEREBY CERTIFY THAT THIS PLAN SET WAS PREPARED BY ME OR UNDER MY DIRECT SUPERVISION OTHER THAN THE EXCEPTIONS NOTED IN THE SHEET INDEX, AND THAT I AM A DULY LICENSED PROFESSIONAL ENGINEER UNDER THE LAWS OF THE STATE OF NORTH DAKOTA.

GROUNDING PLAN
SIERRA (ND240019)
VALLEY CITY, NORTH DAKOTA

SUBMITTAL:

INT.	DATE:	DESCRIPTION:
TJT	09/16/25	REV A

CHECKED BY:	OGD
PLOT DATE:	9/16/2025
PROJECT NUMBER:	44155
SET TYPE:	PRELIM
SHEET NUMBER:	E-101

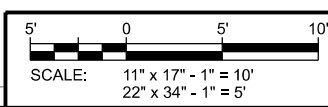

L:\44100\44155\Design\CAD\CDD\PE\E-101.dgn

KEYNOTES: (THIS SHEET)

- A. PRIMARY ELECTRIC UTILITY SERVICE INSTALLED BY UTILITY PROVIDER; APPROX. 10'± FROM EXISTING UTILITY POLE TO PROPOSED TRANSFORMER AT COMPOUND (SOURCE TBD)
- B. GROUND MOUNTED ELECTRIC TRANSFORMER INSTALLED BY UTILITY PROVIDER
- C. PROPOSED FIBER PROVIDER FIBER VAULT WITHIN ROW TO BE INSTALLED BY FIBER PROVIDER (SOURCE TBD)
- D. PROPOSED FIBER VAULT BY GENERAL CONTRACTOR
- E. (1) ORANGE 2" DIA. HDPE, SDR 13.5 SMOOTH WALL CONTINUOUS CONDUIT W/ PULL ROPE FOR FIBER OPTIC LINE; APPROX. 60'± FROM PROPOSED FIBER VAULT WITHIN ROW TO PROPOSED FIBER VAULT AT COMPOUND (SOURCE TBD); BY GENERAL CONTRACTOR

GENERAL NOTES: (THIS SHEET)

1. CONTRACTOR SHALL FIELD VERIFY DEPTHS, LOCATIONS, & SIZES OF ALL EXISTING UTILITIES.
2. ALL UTILITIES SHALL BE INSTALLED ACCORDING TO STATE AND LOCAL REQUIREMENTS.
3. ALL ELECTRICAL WORK SHALL CONFORM TO NATIONAL, STATE, AND LOCAL CODES.
4. ALL UNDERGROUND TRENCHING, PIPE AND CONDUIT INSTALLATION TO BE COMPLETED PRIOR TO FINAL SUBGRADE COMPACTION AND AGGREGATE INSTALLATION.
5. ALL CONDUCTORS TO BE COPPER.
6. ALL UNDERGROUND ELECTRICAL & TELCO CONDUITS TO BE SCH. 80 PVC UNLESS OTHERWISE REQUIRED BY THE UTILITY PROVIDER.
7. ALL OUTDOOR ABOVE GROUND EXPOSED ELECTRICAL CONDUITS, ALL CONDUIT STUB UPS AND ANY OUTDOOR/BELOW GRADE CONDUIT TO BE SCH 80 PVC.
8. REFERENCE MANUFACTURER AND CATALOG NUMBERS ARE USED FOR QUALITY AND PERFORMANCE ONLY. EQUIPMENT MFR. BY OTHERS ARE EQUALLY ACCEPTABLE PROVIDED THEY MEET OR EXCEED THE SPEC.
9. PROVIDE AND INSTALL ALL NECESSARY WIRING AND CONDUITS FROM EXTERIOR ELECTRICAL ITEMS TO DISTRIBUTION PANEL WITHIN EQUIPMENT BUILDING.
10. ALL CONDUIT STUBS IN BUILDINGS & PULL BOXES TO BE IDENTIFIED AND LABELED.
11. PROVIDE PULL STRINGS IN ALL CONDUITS.
12. ALL INDOOR EXPOSED CONDUIT TO BE METALLIC (EMT OR RGS).
13. SEE E-503 FOR CONDUIT INSTALLATION REQUIREMENTS.

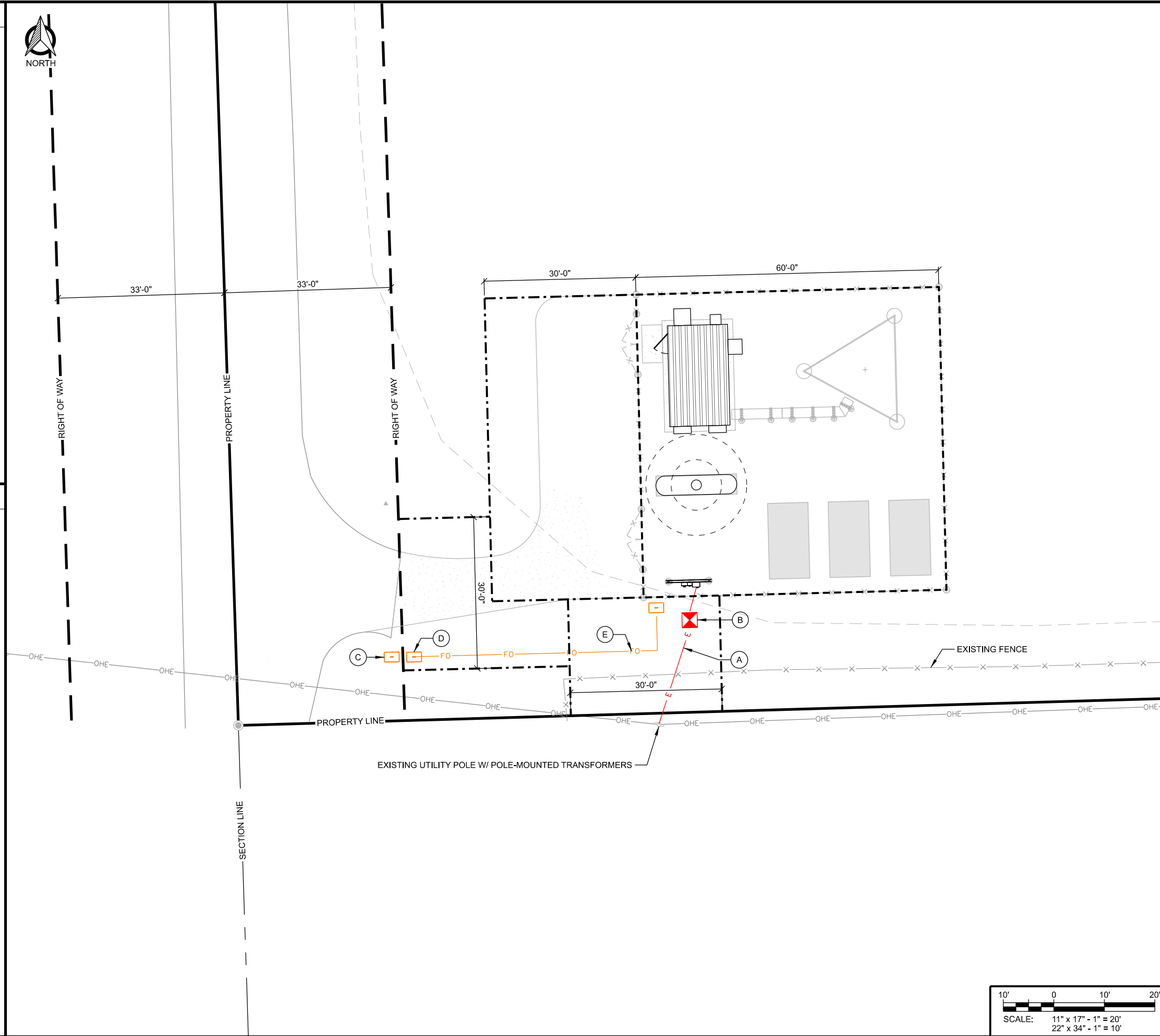

CONSULTANT:
Edge
 Consulting Engineers, Inc.
 2101 HIGHWAY 13 W
 BURNSVILLE, MN 55337
 608.644.1449 VOICE
 608.644.1549 FAX
 www.edgeconsult.com

CLIENT:
Allo Towers
 151 KALMUS DR, SUITE E-201
 COSTA MESA, CA 92626
 949.749.1994 VOICE
 www.allotowers.com

ENGINEER SEAL:
PRELIMINARY - NOT FOR CONSTRUCTION

I HEREBY CERTIFY THAT THIS PLAN SET WAS PREPARED BY ME OR UNDER MY DIRECT SUPERVISION OTHER THAN THE EXCEPTIONS NOTED IN THE SHEET INDEX, AND THAT I AM A DULY LICENSED PROFESSIONAL ENGINEER UNDER THE LAWS OF THE STATE OF NORTH DAKOTA.

**UTILITY PLAN
 SIERRA (ND240019)
 VALLEY CITY, NORTH DAKOTA**

SUBMITTAL:

INT.	DATE:	DESCRIPTION:
TJT	09/16/25	REV A

CHECKED BY:	OGD
PLOT DATE:	9/16/2025
PROJECT NUMBER:	44155
SET TYPE:	PRELIM
SHEET NUMBER:	E-102

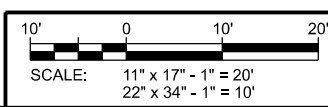

L:\44100\44155\Design\CAD\CD\Plot\E-102.dgn

KEYNOTES: (THIS SHEET)

- A. EQUIPMENT SHELTER
- B. PRIMARY ELECTRIC UTILITY SERVICE INSTALLED BY UTILITY PROVIDER; APPROX. 10'± FROM EXISTING UTILITY POLE TO PROPOSED TRANSFORMER AT COMPOUND (SOURCE TBD)
- C. GROUND MOUNTED ELECTRIC TRANSFORMER INSTALLED BY UTILITY PROVIDER
- D. 600A 120/240V 1P SECONDARY ELECTRIC SERVICE TO UTILITY RACK. (2) 4" CONDUITS INSTALLED BY CONTRACTOR; COORDINATE INSTALLATION WITH UTILITY PROVIDER
- E. UTILITY RACK INSTALLED BY CONTRACTOR E-505 FOR DETAILS
- F. 1,000 GAL. LP TANK; SEE E-506 FOR DETAILS
- G. UTILITY SETBACK / CLEARANCES. 5'-0" AROUND LP TANK VALVE FOR FENCE BUFFER 10'-0" AROUND LP TANK VALVE FOR NO-SPARK BUFFER
- H. (1) ORANGE 2" DIA. HDPE, SDR 13.5 SMOOTH WALL CONTINUOUS CONDUIT W/ PULL ROPE FOR FIBER OPTIC LINE; APPROX. 60'± FROM PROPOSED FIBER VAULT WITHIN ROW TO PROPOSED FIBER VAULT AT COMPOUND (SOURCE TBD); BY GENERAL CONTRACTOR
- I. FIBER VAULT BY GENERAL CONTRACTOR

GENERAL NOTES: (THIS SHEET)

1. CONTRACTOR SHALL FIELD VERIFY DEPTHS, LOCATIONS, & SIZES OF ALL EXISTING UTILITIES.
2. ALL UTILITIES SHALL BE INSTALLED ACCORDING TO STATE AND LOCAL REQUIREMENTS.
3. ALL ELECTRICAL WORK SHALL CONFORM TO NATIONAL, STATE, AND LOCAL CODES.
4. ALL UNDERGROUND TRENCHING, PIPE AND CONDUIT INSTALLATION TO BE COMPLETED PRIOR TO FINAL SUBGRADE COMPACTION AND AGGREGATE INSTALLATION.
5. ALL CONDUCTORS TO BE COPPER.
6. ALL UNDERGROUND ELECTRICAL & TELCO CONDUITS TO BE SCH. 80 PVC UNLESS OTHERWISE REQUIRED BY THE UTILITY PROVIDER.
7. ALL OUTDOOR ABOVE GROUND EXPOSED ELECTRICAL CONDUITS, ALL CONDUIT STUB UPS AND ANY OUTDOOR/BELOW GRADE CONDUIT TO BE SCH 80 PVC.
8. REFERENCE MANUFACTURER AND CATALOG NUMBERS ARE USED FOR QUALITY AND PERFORMANCE ONLY. EQUIPMENT MFR. BY OTHERS ARE EQUALLY ACCEPTABLE PROVIDED THEY MEET OR EXCEED THE SPEC.
9. PROVIDE AND INSTALL ALL NECESSARY WIRING AND CONDUITS FROM EXTERIOR ELECTRICAL ITEMS TO DISTRIBUTION PANEL WITHIN EQUIPMENT BUILDING.
10. ALL CONDUIT STUBS IN BUILDINGS & PULL BOXES TO BE IDENTIFIED AND LABELED.
11. PROVIDE PULL STRINGS IN ALL CONDUITS.
12. ALL INDOOR EXPOSED CONDUIT TO BE METALLIC (EMT OR RGS).
13. SEE E-503 FOR CONDUIT INSTALLATION REQUIREMENTS.

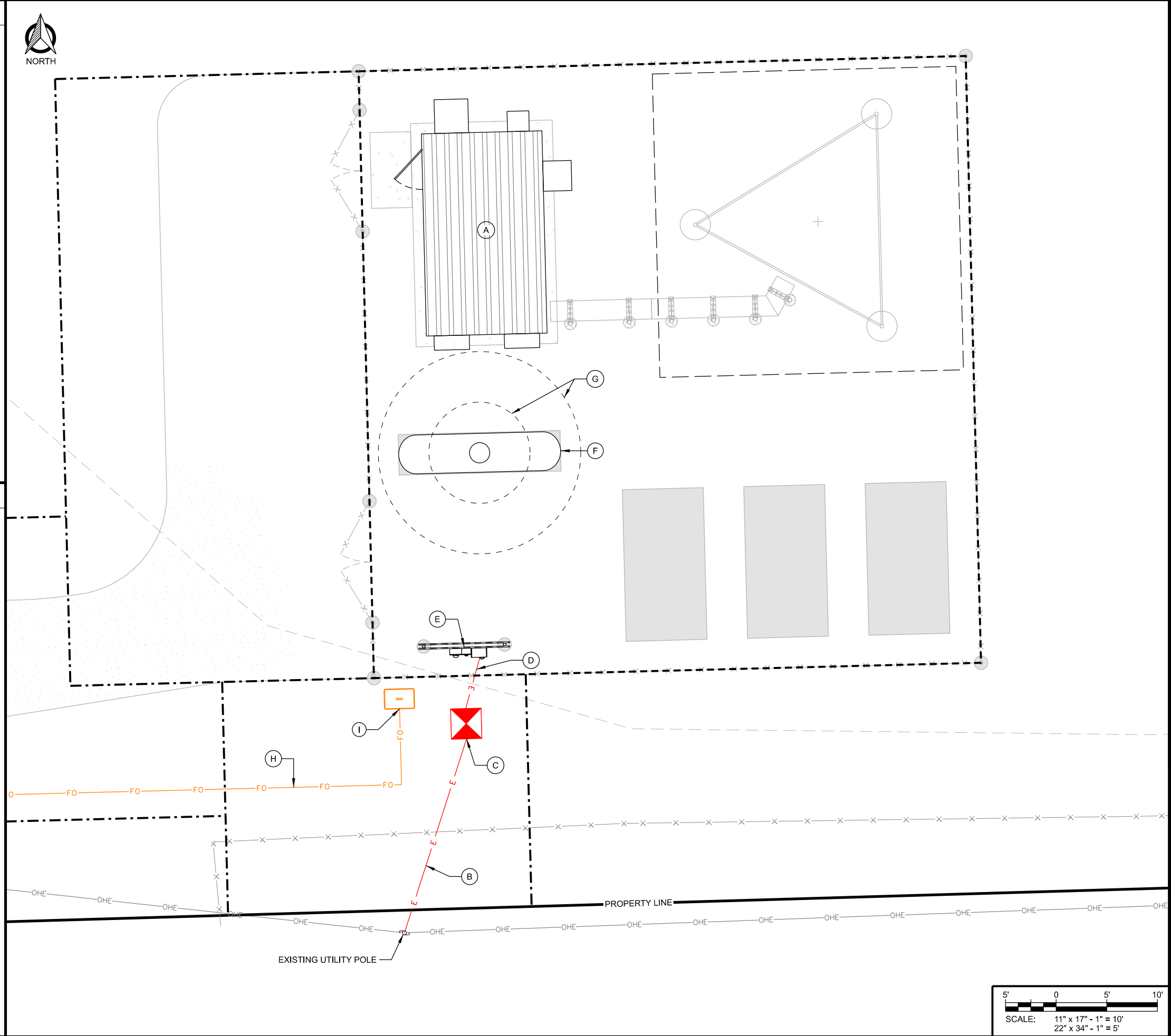

CONSULTANT:
Edge
 Consulting Engineers, Inc.
 2101 HIGHWAY 13 W
 BURNSVILLE, MN 55337
 608.644.1449 VOICE
 608.644.1549 FAX
 www.edgeconsult.com

CLIENT:
Allo Towers
 151 KALMUS DR., SUITE E-201
 COSTA MESA, CA 92626
 949.749.1994 VOICE
 www.allotowers.com

ENGINEER SEAL:
PRELIMINARY - NOT FOR CONSTRUCTION

I HEREBY CERTIFY THAT THIS PLAN SET WAS PREPARED BY ME OR UNDER MY DIRECT SUPERVISION OTHER THAN THE EXCEPTIONS NOTED IN THE SHEET INDEX, AND THAT I AM A DULY LICENSED PROFESSIONAL ENGINEER UNDER THE LAWS OF THE STATE OF NORTH DAKOTA.

ENLARGED UTILITY PLAN
 SIERRA (ND240019)
 VALLEY CITY, NORTH DAKOTA

SUBMITTAL:

INT.	DATE:	DESCRIPTION:
TJT	09/16/25	REV A

CHECKED BY:	OGD
PLOT DATE:	9/16/2025
PROJECT NUMBER:	44155
SET TYPE:	PRELIM
SHEET NUMBER:	E-103

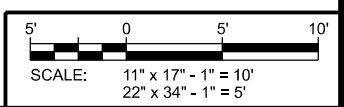

L:\44100\44155\Design\CAD\Plot\E-103.dgn

KEYNOTES: (THIS SHEET)

- A. AIR TERMINAL:
EXTEND 2' ABOVE HIGHEST ANTENNA MIN. ON MAST PIPE
MECHANICALLY FASTEN AIR TERMINAL TO MAST PIPE
PIPE TO BE MECHANICALLY CONNECTED TO TOWER STEEL
- B. COAX / WAVEGUIDE TRANSMISSION LINE GROUND KIT;
SEE DETAIL TO RIGHT
- C. GROUND KIT JUMPER;
CONNECT TO GROUND BAR WITH 2 HOLE LONG BARREL LUG
- D. ANTENNA GROUND BAR (TINNED);
FOR CONNECTION OF MULTIPLE GROUND KITS AT ONE
LEVEL MOUNT TO TOWER STEEL;
INSTALL #2 STRANDED LEAD FROM GROUND BAR TO TOWER
STEEL
- E. FOR SINGLE ANTENNAS AT ONE LEVEL OMIT ANTENNA
GROUND BAR CONNECT GROUND KIT JUMPER DIRECTLY TO
TOWER STEEL WITH UL LISTED BONDING CLAMP
- F. UL LISTED BONDING CLAMP:
- HARGER BGC41.25-2 PIPE CLAMPS FOR
1-1/4" TO 2" DIA. ROUND MEMBERS
OR
- HARGER #223T HEAVY DUTY TINNED FLANGE
BONDING PLATE
- USE EXTERNAL ANTI-OXIDATION COMPOUND.
- PAINT WITH COLD GALV. COMPOUND AFTER BONDING.
- G. TOWER GROUND BAR (TGB) (TINNED);
4" x 18" x 1/2" - SIZED FOR (30) 2 HOLE GROUND LUGS MOUNT
DIAGONALLY FOR EASIER HOOK-UP OF GROUNDING KIT
LEADS INSTALL ON TOWER WITH INSULATORS AT 12" (ABOVE
ICE BRIDGE)
- H. TGB GROUNDS;
#2 BARE SOLID TINNED ENCASED IN CARFLEX CONDUIT
FROM TGB TO TOWER GROUND RING (2) REQ'D AND FROM
TGB TO TOWER STEEL (1) REQ'D
- I. TOWER STEEL GROUNDS;
#2 BARE SOLID TINNED ENCASED IN CARFLEX CONDUIT
FROM TOWER STEEL TO TOWER GROUND RING (3) REQ'D.
- J. TOWER FOUNDATION GROUND, (1 REQ'D);
SEE E-502 FOR DETAILS
- K. SHELTER EXTERIOR GROUND BAR (EGB) (TINNED);
SEE DETAIL TO RIGHT
- L. EGB GROUNDS;
#2 BARE SOLID TINNED
SEE DETAIL TO RIGHT
ENCASE IN CARFLEX CONDUIT FROM EGB TO SHELTER
GROUND RING (2) REQ'D.
- M. SURGE ARRESTOR/POLY PHASER
- N. INTERIOR SHELTER GROUND BAR / MASTER GROUND BAR
(MGB);
SEE DETAIL TO RIGHT
- O. #2 BARE SOLID TINNED, ENCASE IN CARFLEX CONDUIT
FROM MGB TO SHELTER GROUND RING (2) REQ'D.;
SEE DETAIL TO RIGHT
- P. ICE BRIDGE POST GROUNDS;
#2 BARE SOLID TINNED ENCASE IN CARFLEX CONDUIT TO 24"
BELOW GRADE;
SEE E-502 FOR DETAILS
- Q. ICE BRIDGE SECTION GROUNDS;
#6 STRANDED INSULATED
2 HOLE LONG BARREL ON EACH END (TYP.)
- R. ICE BRIDGE SECTION TO POST GROUNDS;
#6 STRANDED INSULATED
2 HOLE LONG BARREL ON SECTION & CADWELDED TO POST
ORIENT LEAD WITH HIGH SIDE TOWARDS TOWER
- S. ENTRY PANEL GROUND;
#6 STRANDED INSULATED
2 HOLE LONG BARREL ON EACH END (TYP.)

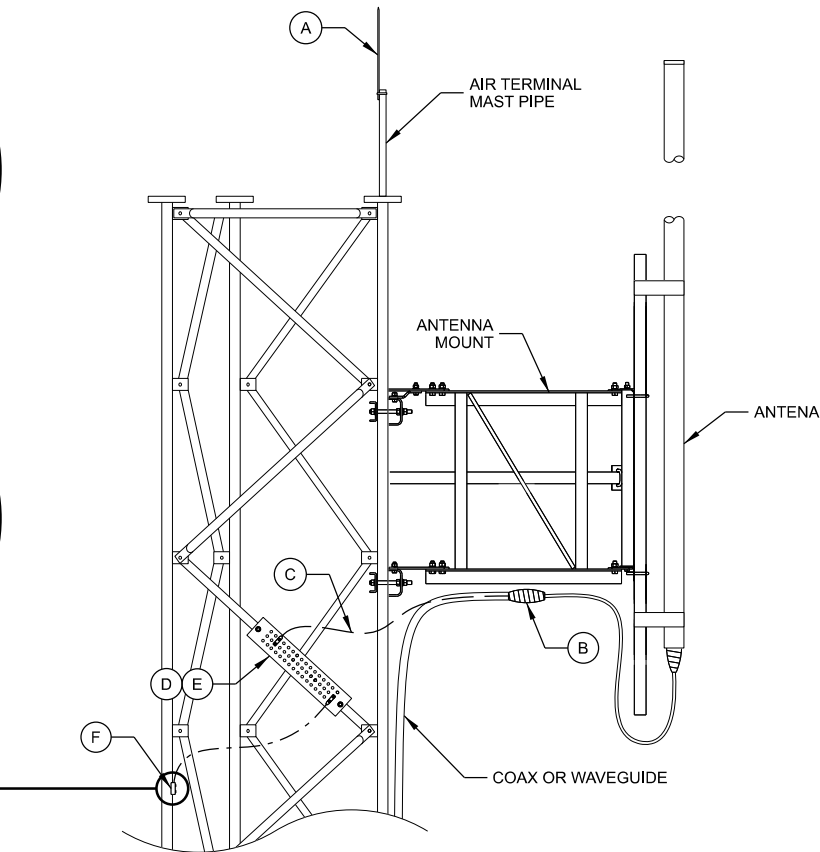
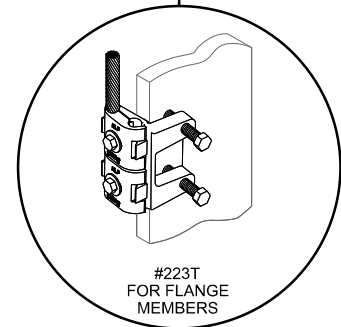
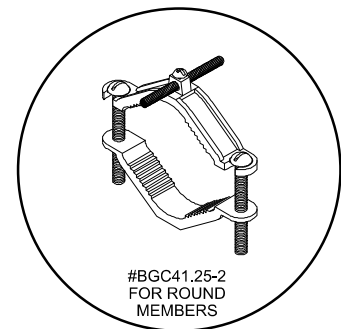

A ANTENNA LEVEL GROUNDING

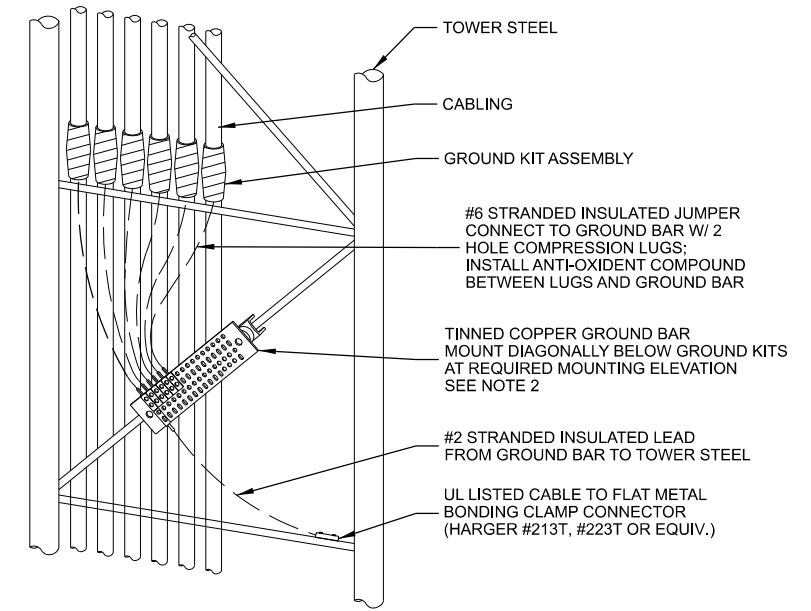

- NOTES:
- INSTALL GROUND KITS ON EACH TRANSMISSION LINE IN THE FOLLOWING LOCATIONS:
 - A. ANTENNA / DISH LEVEL
 - B. AT 75 FOOT MAX INTERVALS FROM ANTENNA LEVEL TO BASE OF TOWER
 - C. TOWER BASE
 - D. EQUIPMENT BUILDING ENTRY
 - INSTALL ANTENNA GROUND BARS AT EACH ANTENNA TIER LEVEL FOR CONNECTION OF MULTIPLE ANTENNAS AT EACH LEVEL. WHEN ONLY ONE ANTENNA IS INSTALLED AT A LEVEL, CONNECT GROUND KIT DIRECTLY TO TOWER STEEL WITH UL LISTED BONDING CLAMP.

C TRANSMISSION LINE GROUNDING

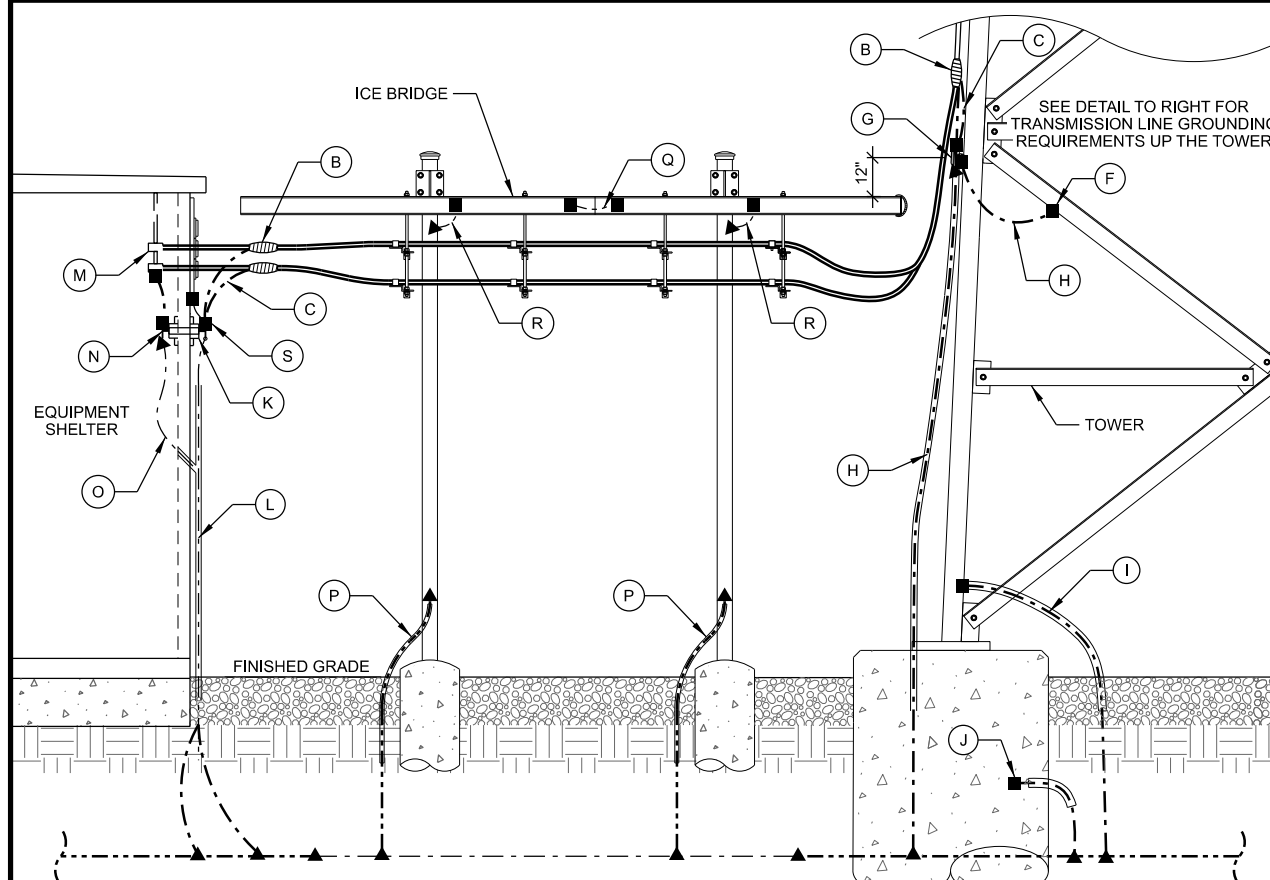

B SITE LEVEL GROUNDING

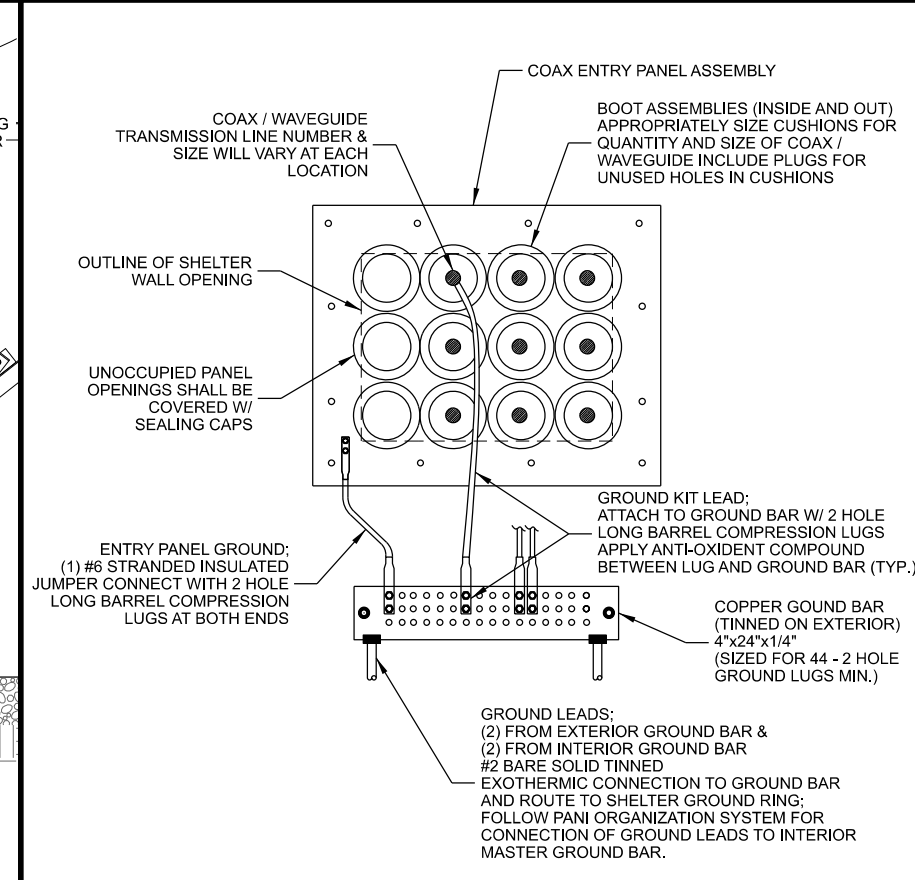

D INTERIOR / EXTERIOR SHELTER GROUND BARS

CONSULTANT:
Edge
Consulting Engineers, Inc.
2101 HIGHWAY 13 W
BURNSVILLE, MN 55337
608.644.1449 VOICE
608.644.1549 FAX
www.edgeconsult.com

CLIENT:
Allo Towers
151 KALMUS DR., SUITE E-201
COSTA MESA, CA 92626
949.749.1994 VOICE
www.allotowers.com

ENGINEER SEAL:
**NOT PRELIMINARY -
NOT FOR CONSTRUCTION**

I HEREBY CERTIFY THAT THIS PLAN SET WAS PREPARED BY ME OR UNDER MY DIRECT SUPERVISION OTHER THAN THE EXCEPTIONS NOTED IN THE SHEET INDEX, AND THAT I AM A DULY LICENSED PROFESSIONAL ENGINEER UNDER THE LAWS OF THE STATE OF NORTH DAKOTA.

GROUNDING DETAILS
SIERRA (ND240019)
VALLEY CITY, NORTH DAKOTA

SUBMITTAL:

INT.	DATE:	DESCRIPTION:
TJT	09/16/25	REV A

CHECKED BY:	OGD
PLOT DATE:	9/16/2025
PROJECT NUMBER:	44155
SET TYPE:	PRELIM
SHEET NUMBER:	E-501

L:\44100\44155\Design\CAD\CD\Plot\E-501.dgn

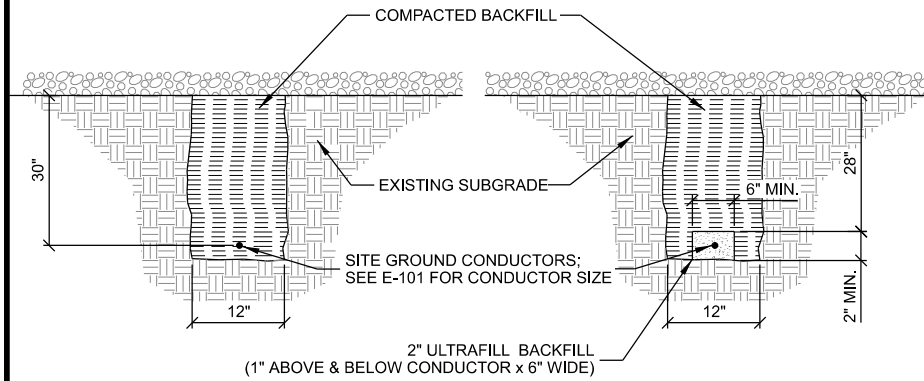

A GROUNDING TRENCH

- NOTES:
- GROUNDING TRENCHES TO BE BACK FILLED WITH NATIVE SOIL.
 - COMPACT BACK FILL TO 95% MODIFIED PROCTOR.

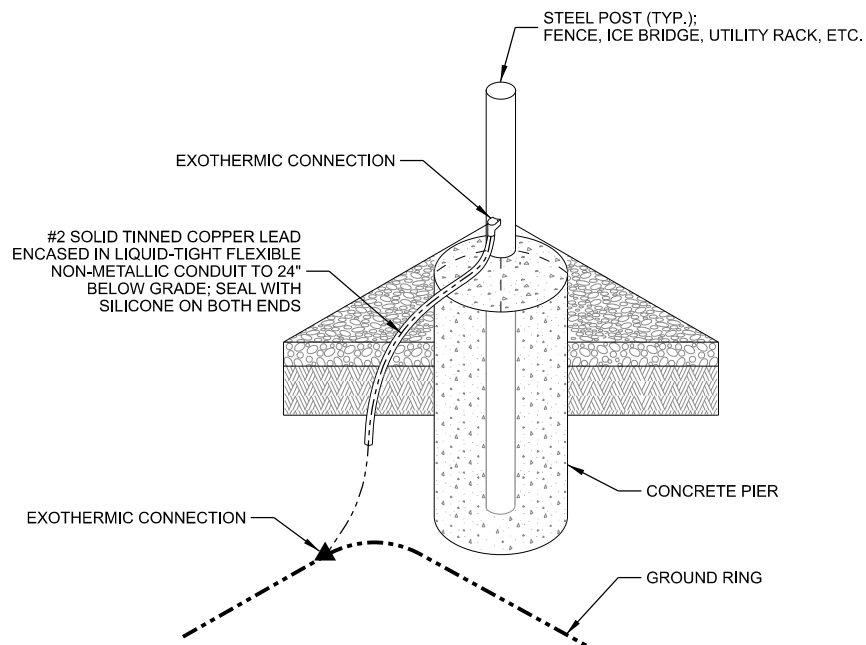

B STEEL POST GROUNDING

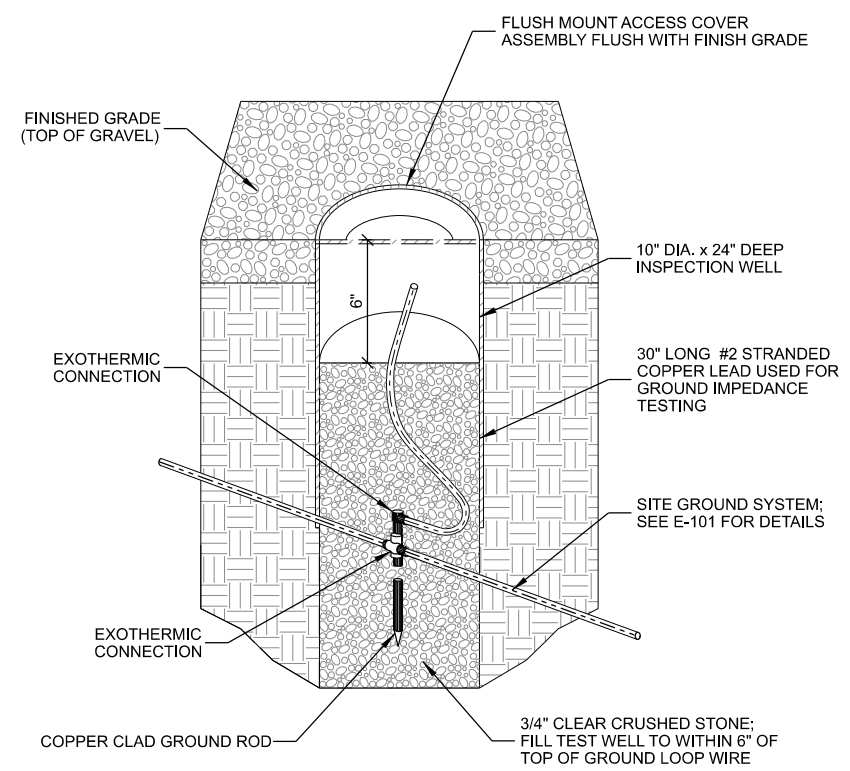

C INSPECTION WELL

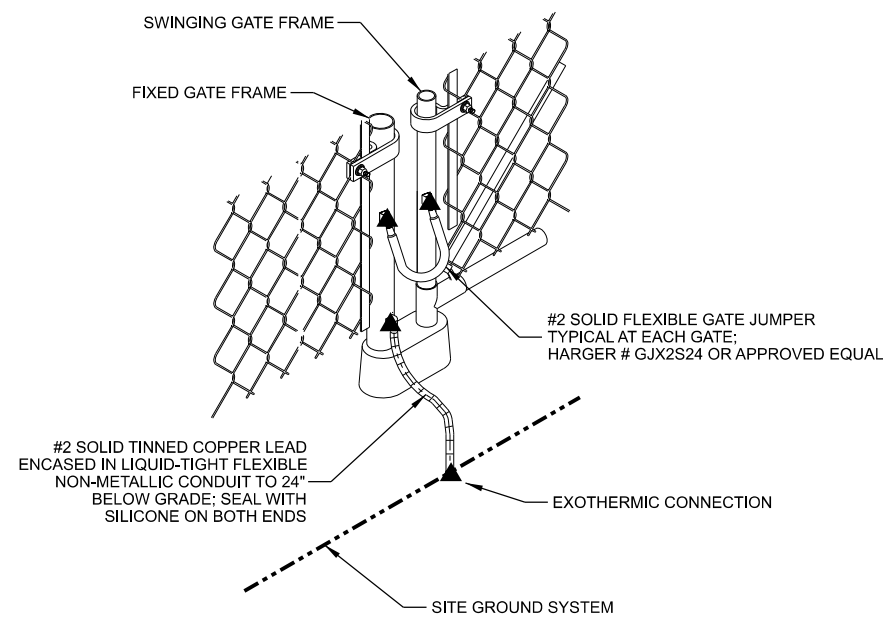

D FENCE GATE GROUNDING

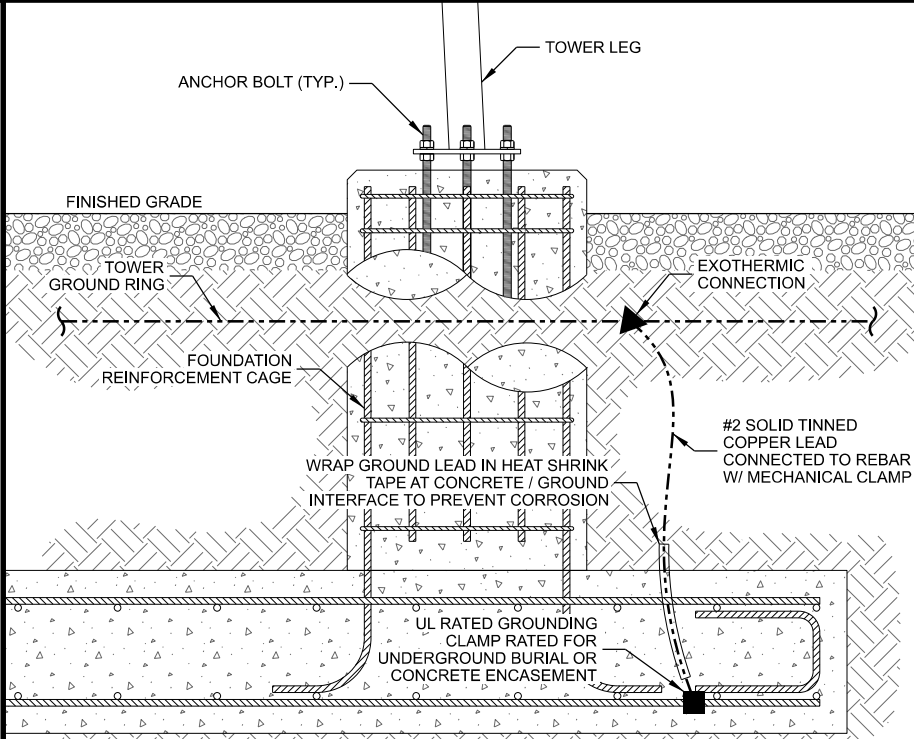

- NOTES:
- FOUNDATION SHOWN IS TYPICAL. SEE TOWER FOUNDATION PLANS FOR REINFORCEMENT DETAILS.
 - FOUNDATION GROUNDING PER NEC 250.52(3)(A). GROUNDING CONNECTIONS TO BE COVERED BY A MINIMUM OF 3" CONCRETE AND BE MADE TO A MIN. 20" CONTINUOUS REBAR.

E TOWER FOUNDATION GROUNDING

THIS SPACE INTENTIONALLY LEFT BLANK

CONSULTANT:
Edge
 Consulting Engineers, Inc.
 2101 HIGHWAY 13 W
 BURNSVILLE, MN 55337
 608.644.1449 VOICE
 608.644.1549 FAX
 www.edgeconsult.com

CLIENT:
Allo Towers
 151 KALMUS DR., SUITE E-201
 COSTA MESA, CA 92626
 949.749.1994 VOICE
 www.allotowers.com

ENGINEER SEAL:
PRELIMINARY - NOT FOR CONSTRUCTION

I HEREBY CERTIFY THAT THIS PLAN SET WAS PREPARED BY ME OR UNDER MY DIRECT SUPERVISION OTHER THAN THE EXCEPTIONS NOTED IN THE SHEET INDEX, AND THAT I AM A DULY LICENSED PROFESSIONAL ENGINEER UNDER THE LAWS OF THE STATE OF NORTH DAKOTA.

GROUNDING DETAILS
 SIERRA (ND240019)
 VALLEY CITY, NORTH DAKOTA

SUBMITTAL:

INT.	DATE:	DESCRIPTION:
TJT	09/16/25	REV A

CHECKED BY:	OGD
PLOT DATE:	9/16/2025
PROJECT NUMBER:	44155
SET TYPE:	PRELIM
SHEET NUMBER:	E-502

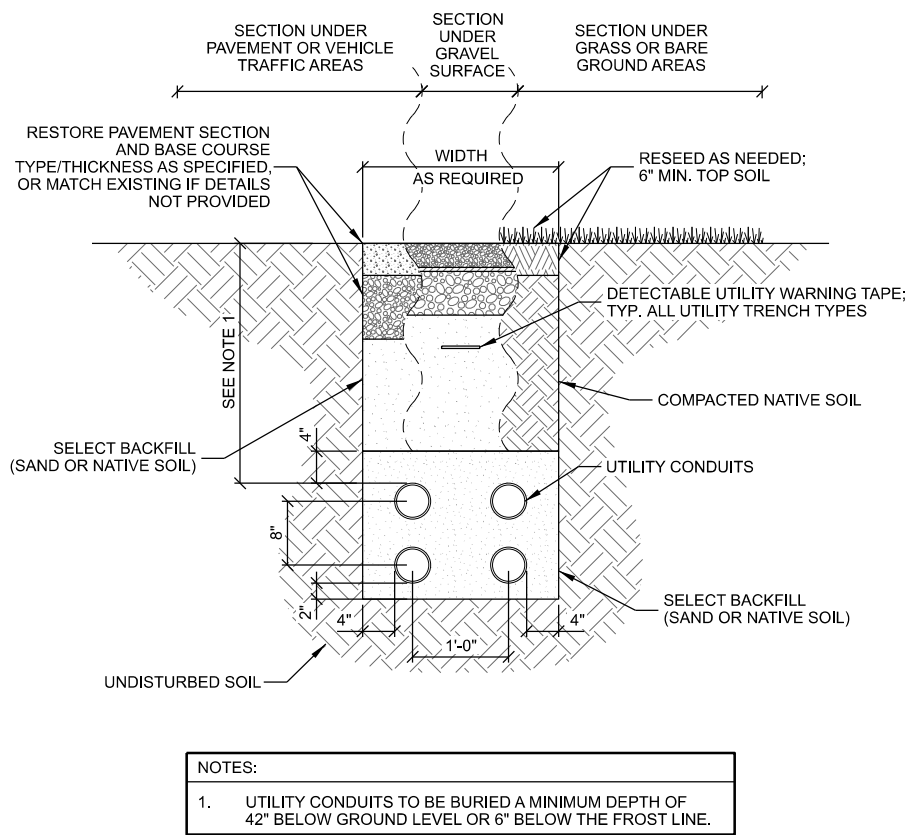

NOTES:

1. UTILITY CONDUITS TO BE BURIED A MINIMUM DEPTH OF 42" BELOW GROUND LEVEL OR 6" BELOW THE FROST LINE.

A UTILITY TRENCH

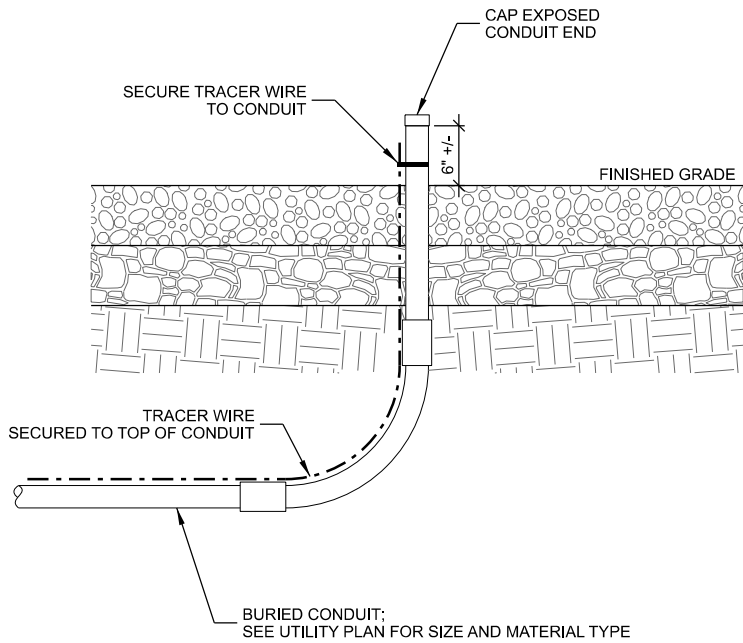

B CONDUIT STUB-UP

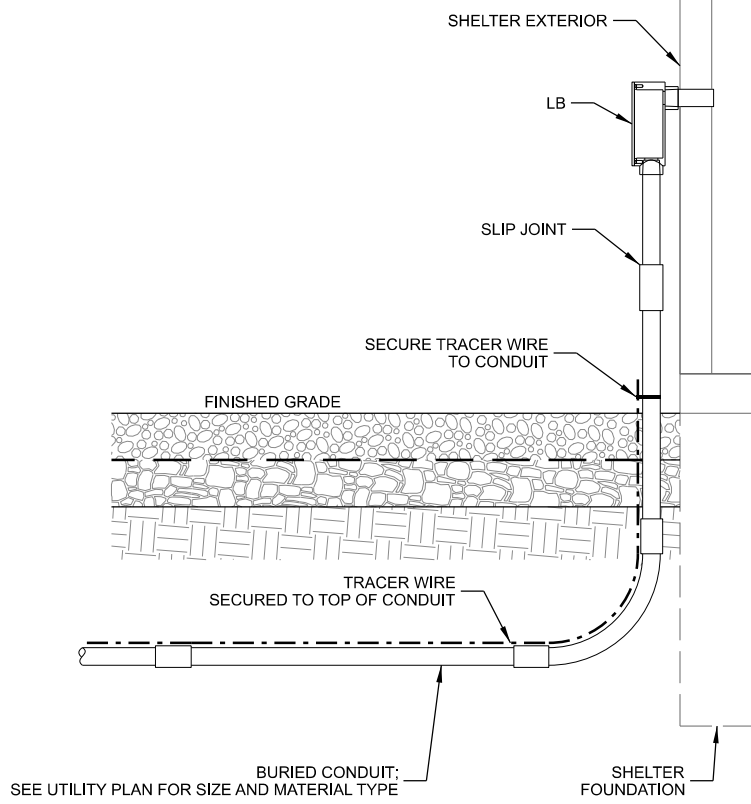

C CONDUIT STUB-UP AT SHELTER

MANUFACTURER: QUAZITE
 MODEL: PG2436BA36 (SPlice BOX)
 PG2436BA24 (PULL BOX)
 PG2436KK00 (COVER)
 INSIDE DIMENSIONS:
 36" x 24" x 36" (L x W x D) SPLICE BOX
 36" x 24" x 24" (L x W x D) PULL BOX
 POLYMER CONCRETE BOX WITH OPEN BOTTOM

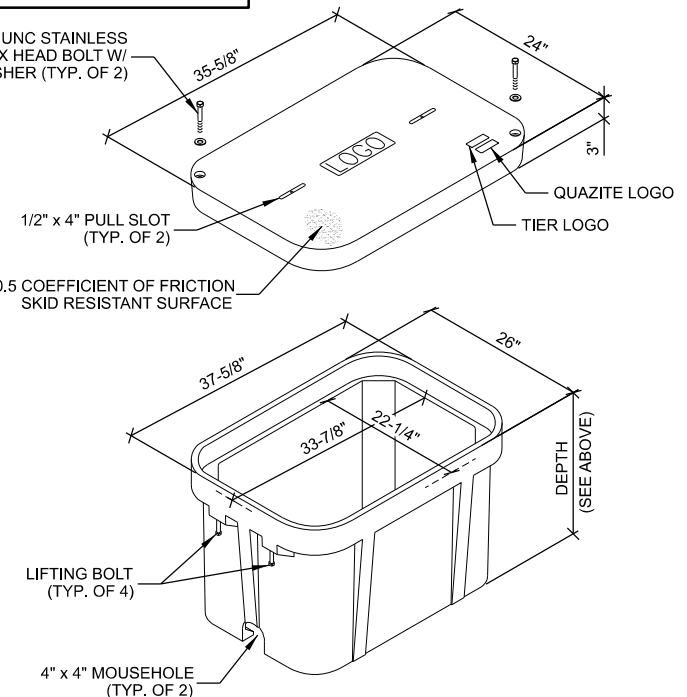

D UTILITY VAULT

THIS SPACE INTENTIONALLY LEFT BLANK

- WARNING TAPE & TRACE WIRE NOTES: (THIS SHEET)**
1. WARNING TAPE TO BE INSTALLED ABOVE THE ELECTRICAL RUN FROM THE GENERATOR TO THE PLATFORM AND ABOVE THE FUEL LINE BETWEEN THE GENERATOR AND FUEL SOURCE.
 2. WARNING TAPE SHALL BE RUN CONTINUOUSLY ALONG THE ENTIRE LENGTH AND INSTALLED 12 INCHES ABOVE THE TOP OF THE CONDUITS
 3. TRACER WIRE SHALL RUN CONTINUOUSLY ALONG THE ENTIRE LENGTH OF THE BURIED GAS AND ELECTRIC CONDUITS
 4. TRACER WIRE SHALL BE SECURED TO THE CONDUIT AND MAINTAINED ABOVE THE CONDUIT CENTERLINE DURING TRENCH BACKFILLING.
 5. TRACER WIRE TO EXTEND TO THE TOP OF PVC ABOVE CONCRETE ON BOTH ENDS - LOOP AND WRAP AROUND APPROPRIATE CONDUIT.
 6. TRACER WIRE SHALL CONSIST OF 14GA. SOLID COPPER WIRE WITH A CORROSION PROTECTIVE COATING.
 7. INSTALL TRACER WIRE WITH SPACER AND SECURE PER MNFG. RECOMMENDATIONS - AT A MIN. EVERY 10' AND AT ALL BENDS. - DO NOT WRAP BURIED CONDUIT WITH TRACER WIRE TO AVOID UNNECESSARY STRESS ON TRACER. - CONTRACTOR TO CHECK CONTINUITY OF TRACER WIRE BEFORE AND AFTER BURIAL AND DOCUMENT RESULTS. 12" ABOVE THE TOP OF THE CONDUITS.

CONSULTANT:
Edge
 Consulting Engineers, Inc.
 2101 HIGHWAY 13 W
 BURNSVILLE, MN 55337
 608.644.1449 VOICE
 608.644.1549 FAX
 www.edgeconsult.com

CLIENT:
Allo Towers
 151 KALMUS DR., SUITE E-201
 COSTA MESA, CA 92626
 949.749.1994 VOICE
 www.allotowers.com

ENGINEER SEAL:
PRELIMINARY - NOT FOR CONSTRUCTION

I HEREBY CERTIFY THAT THIS PLAN SET WAS PREPARED BY ME OR UNDER MY DIRECT SUPERVISION OTHER THAN THE EXCEPTIONS NOTED IN THE SHEET INDEX, AND THAT I AM A DULY LICENSED PROFESSIONAL ENGINEER UNDER THE LAWS OF THE STATE OF NORTH DAKOTA.

UTILITY DETAILS
 SIERRA (ND240019)
 VALLEY CITY, NORTH DAKOTA

SUBMITTAL:

INT.	DATE:	DESCRIPTION:
TJT	09/16/25	REV A

CHECKED BY:	OGD
PLOT DATE:	9/16/2025
PROJECT NUMBER:	44155
SET TYPE:	PRELIM
SHEET NUMBER:	E-503

L:\44100\44155\Design\CAD\CD\Plot\E-503.dgn

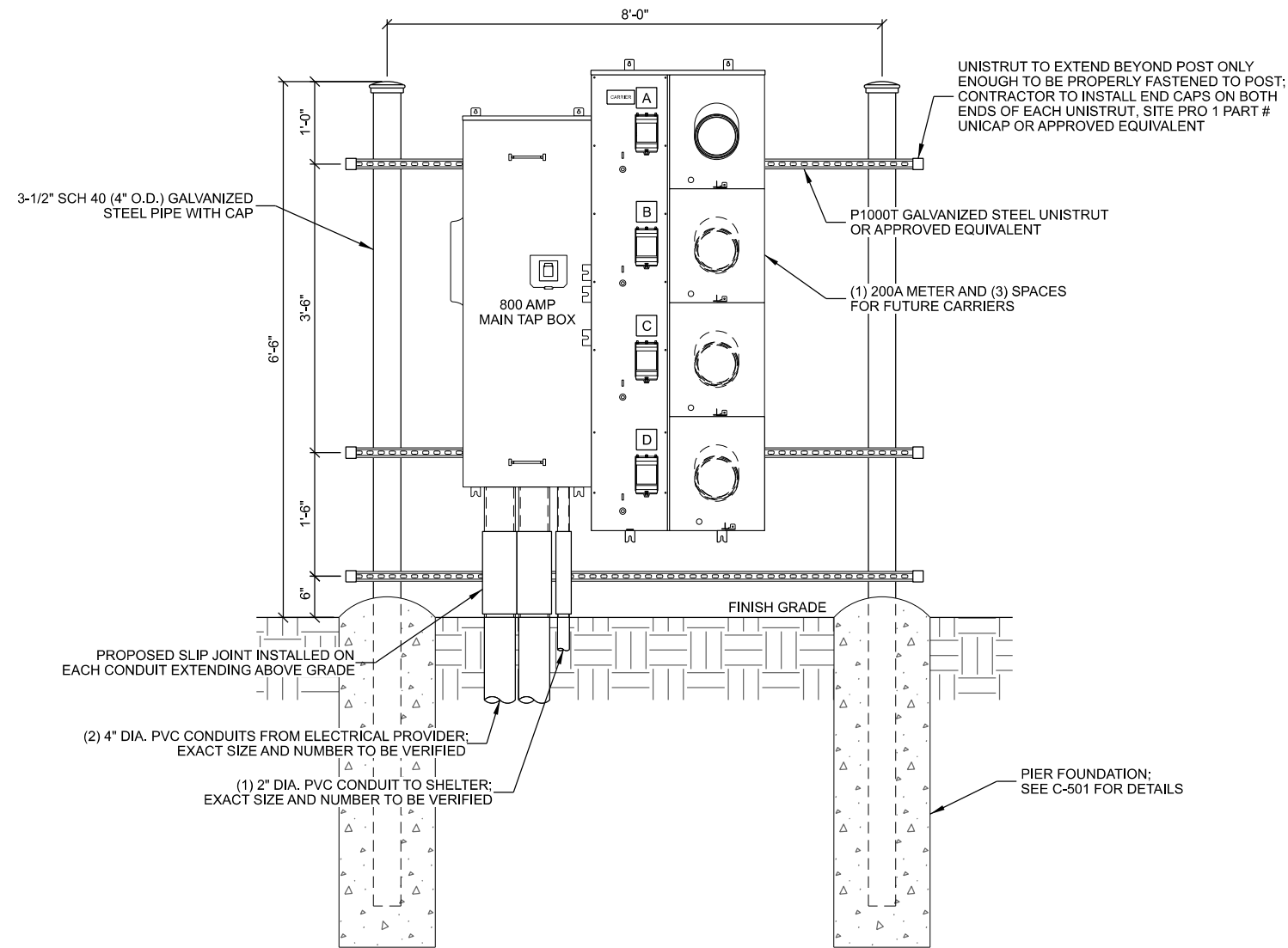

FRONT - ELECTRICAL SIDE

NOTE:

1. INSTALL PVC CONDUITS FOR SERVICE LATERAL CONNECTION TO UTILITY.
2. EXTEND SERVICE LATERAL CONDUITS UNDERGROUND BEYOND FENCELINE. CAP ENDS (NO DUCT TAPE ALLOWED) AND STAKE, EQUIP WITH PULL CORD, VERIFY REQUIREMENTS W/UTILITY PROVIDER.
3. MARK CARRIER METER SLOT @ BREAKER OR SOCKET EXTERIOR.
4. SQD EZ METER PAK, 120/240 VAC 1 PHASE, 3 WIRE OR EQUIV., VERIFY REQUIREMENTS WITH UTILITY PROVIDER
5. FINAL LAYOUT AND DESIGN DETERMINED BY CONTRACTOR/UTILITY, VERIFY FINAL DESIGN WITH THE CARRIER.

A MULTI-METER UTILITY RACK

SCALE: 11" x 17" - 1/2" = 1'-0"
22" x 34" - 1" = 1'-0"

CONSULTANT:

Edge
Consulting Engineers, Inc.
2101 HIGHWAY 13 W
BURNSVILLE, MN 55337
608.644.1449 VOICE
608.644.1549 FAX
www.edgeconsult.com

CLIENT:

Allo Towers
151 KALMUS DR, SUITE E-201
COSTA MESA, CA 92626
949.749.1994 VOICE
www.allotowers.com

ENGINEER SEAL:

PRELIMINARY - NOT FOR CONSTRUCTION

I HEREBY CERTIFY THAT THIS PLAN SET WAS PREPARED BY ME OR UNDER MY DIRECT SUPERVISION OTHER THAN THE EXCEPTIONS NOTED IN THE SHEET INDEX, AND THAT I AM A DULY LICENSED PROFESSIONAL ENGINEER UNDER THE LAWS OF THE STATE OF NORTH DAKOTA.

UTILITY DETAILS
SIERRA (ND240019)
VALLEY CITY, NORTH DAKOTA

SUBMITTAL:

INT.	DATE:	DESCRIPTION:
TJT	09/16/25	REV A

CHECKED BY:	OGD
PLOT DATE:	9/16/2025
PROJECT NUMBER:	44155
SET TYPE:	PRELIM
SHEET NUMBER:	E-504

RESOLUTION NO. 2505

**A RESOLUTION APPROVING CONDITIONAL USE PERMIT
AUDITORS LOT 1 AND THE S 360' OF THE E 820' OF AUDITOR'S LOT 2
NW¼ SECTION 32-140-58**

WHEREAS, an application was submitted to the Valley City Planning and Zoning Commission requesting a Conditional Use Permit (CUP) to construct telecommunications facilities on the following land within the extraterritorial jurisdiction of the City of Valley City, North Dakota:

Auditors Lot 1 and the south 360 feet of the east 820 feet of Auditor's Lot 2 both of the NW¼ of Section 32 Township 140 North Range 58 West in Barnes County, North Dakota, having an area of approximately 65.39 acres

and;

WHEREAS, the Planning and Zoning Commission, following a public hearing on October 14, 2025, recommended approval of the CUP with conditions; and

WHEREAS, pursuant to section 11-07-02 of the Valley City Municipal Code, if a CUP is granted, the Board of City Commissioners may impose any special conditions it considers necessary to protect the public health, safety and welfare and to achieve the purposes of the City Zoning Code.

THEREFORE, BE IT HEREBY RESOLVED, by the Board of City Commissioners of the City of Valley City, Barnes County, North Dakota, hereby approves the Conditional Use Permit for Auditors Lot 1 and the south 360 feet of the east 820 feet of Auditor's Lot 2 both of the NW¼ of Section 32 Township 140 North Range 58 West in Barnes County, North Dakota, with the following conditions:

1. The proposed tower and tower height must be approved by the FAA, and meet all FAA requirements such as installation of appropriate lighting or beacons to warn aircraft of the potential hazard.
2. The proposed tower must be at least 225 feet east of the County Road 19 right-of-way.
3. The Barnes County Municipal Airport manager must not indicate any reservations or objections to the installation of the tower if the previous two conditions are met.
4. A re-zone of the property to AG Agricultural District must be approved by the Board on November 18, 2025.

Passed, adopted and approved this 21st day of October, 2025.

Dave Carlsrud, President
Board of City Commissioners

ATTEST:

Brenda Klein, Finance Director

October 21, 2025

Sam Halawi
Allo Towers Inc.
5151 California Ave
Irvine, CA 92617

RE: Proposed 194' (Extendable to 250') Sabre Self-Supporting Tower for Sierra, ND

Dear Mr. Halawi,

Upon receipt of order, we propose to design a tower for the above referenced project for a Basic Wind Speed of 117 mph with no ice and 50 mph + 1" ice, Risk Category III, Exposure Category C, and Topographic Category 1 in accordance with the Telecommunications Industry Association Standard ANSI/TIA-222-H, "Structural Standard for Antenna Supporting Structures, Antennas and Small Wind Turbine Supporting Structures.

When designed according to this standard, the wind pressures and steel strength capacities include several safety factors. Therefore, it is highly unlikely that the tower will fail structurally in a wind event where the design wind speed is exceeded within the range of the built-in safety factors.

Should the wind speed increase beyond the capacity of the built-in safety factors, to the point of failure of one or more structural elements, the most likely location of the failure would be within one or more of the tower members in the upper portion. This would result in a buckling failure mode, where the loaded member would bend beyond its elastic limit (beyond the point where the member would return to its original shape upon removal of the wind load).

Therefore, it is likely that the overall effect of such an extreme wind event would be localized buckling of a tower section. Assuming that the wind pressure profile is similar to that used to design the tower, the tower is most likely to buckle at the location of the highest combined stress ratio in the upper portion of the tower. This would result in the portion of the tower above the failure location "folding over" onto the portion of the tower below the failure location. *Please note that this letter only applies to the above referenced tower designed and manufactured by Sabre Industries.* In the unlikely event of total separation, this would result in a fall radius of 115' or less at ground level.

Sincerely,

Thomas T. Wilson, P.E.
Design Engineer II

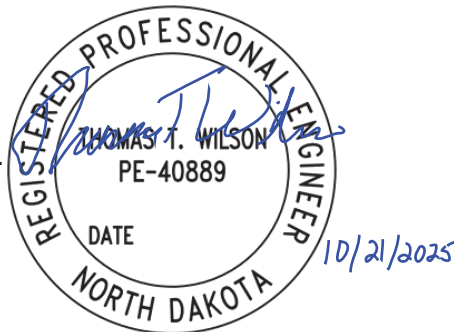

sabre

Sabre Industries, Inc.

7101 Southbridge Drive
Sioux City, IA 51111

Valley City Planning and Zoning APPLICATION

Procedures and submission requirements can be found in the Valley City Municipal Code. Application and fees must be submitted as soon as possible in order to allow sufficient time for publication of required public hearing notices. The Planning and Zoning Commission generally meets and holds public hearings the 2nd Tuesday of every month at 4pm. Additional fees will be assessed if it is determined a meeting is needed to be held outside of regularly scheduled meeting dates.

Please check all that apply and submit payment with application. This application may be utilized for more than one request or applicant may copy and attach a separate application for each item as needed.

- | | |
|---|--|
| <input type="checkbox"/> Plat/Replat (\$150 + \$2 per lot)
<input type="checkbox"/> Recording Fee (1- 49 lots - \$30 - 50+ lots \$60)*
<input type="checkbox"/> Variance (\$100)
<input type="checkbox"/> Vacation of Street/Alley (\$150)
<input type="checkbox"/> Zoning Ordinance Text Amendment (\$200) | <input checked="" type="checkbox"/> Zoning Map Amendment (Zone/Rezone) (\$200)
<input type="checkbox"/> Conditional Use Permit (\$200)
<input type="checkbox"/> PUD/PUD Amendment (\$200)
<input type="checkbox"/> Other: _____ (\$TBD) |
|---|--|
- *Recording fee is refundable if plat/replat is denied

Applicant Name: City of Valley City Phone: 701-845-1700

Applicant Address: 220 3rd ST NE

City, State, Zip: Valley City ND 58072 **Email Address:** joel.gumbert@kling.com

Owner Name: City of Valley City Phone: 701-845-1700

Owner Address: 220 3rd ST NE

City, State, Zip: Valley City ND 58072 **Email Address:** _____

Owner Authorization: _____ **Date:** _____
If the applicant is not the same as the owner, the owner must sign the application or submit a letter authorizing the applicant to proceed on behalf of the owner.

Physical Address of Property (if assigned): _____

Property Description (attach add'l sheet if necessary):

Parcel ID# 413220200 **Lot** _____ **Block** _____ **Subdivision** _____

Section 32 **Twp** 140 **Range** 58 **Metes and Bounds:** Auditors Lot 1 and S360' of E820' of Auditors Lot 2 of the NW 1/4 Sect 32 Twp 140 Rng 58

Briefly describe the reason for request:
Establish zoning for city owned land to allow consideration of approval for a public safety telecommunications facility conditional use permit.

Applicant Signature: _____ **Date:** _____

The signature of the applicant and owner (or written permission of the owner) certifies that permission is granted by the owner to all authorized City personnel to enter the property for the purpose of review of this application. The applicant and owner further certify that all City Ordinances will be complied with and that the information given within this application as well as the plans submitted are in all respects true and correct to the best of my knowledge and belief.

VALLEY CITY USE ONLY:

Application and fees. Rec'd on date: _____ In the amount of \$ _____ Cash/Check

Application/Supporting documents deemed complete. Date: _____ Initials _____

P&Z: **Hearing Date** _____ **Approval:** Yes Yes with conditions No
Publication Dates:
P&Z findings and recommendations sent to City Commission. Date: _____

City Commission: **Hearing Date** _____ **Approval:** Yes Yes with conditions No
Publication Dates:

Valley City Planning Commission – October 14, 2025 Agenda

Action Request: Zoning Application

Applicant: City of Valley City

Objective: Assign Agricultural District status to a tract of land owned by the City of Valley City to allow construction and operation of a public safety telecommunications tower on the site.

Property Owners: City of Valley City

Legal Description: Auditors Lot 1 and the south 360 feet of the east 820 feet of Auditor’s Lot 2 both of the NW ¼ of Section 32 Twp 140N Rng 58W in Barnes County, North Dakota, having an area of approximately 65.39 acres.

Project Location: The land proposed to be zoned is located east of County Road 19 and contains part of the Valley City sewage lagoons. See maps below.

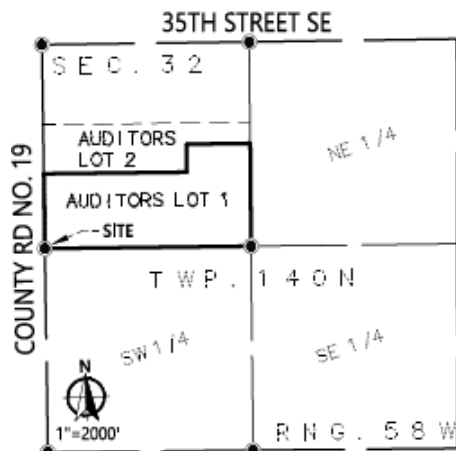

Analysis: The land included in this proposed zoning assignment is in the extraterritorial area of Valley City and was zoned Agricultural by Barnes County prior to the establishment of extraterritorial area by the City of Valley City. The land is owned by the City of Valley City. Part of the land is used for farming and part contains one pond of the Valley City sewage lagoon system.

As part of an upgrade to the state-wide public communications system, the State of North Dakota needs to construct a wireless communications tower in the Valley City area for state, regional, and local first responders to use.

Wireless communication facilities are a conditional use in the Agricultural District. The intent of the Agricultural District is for agricultural activities and other open land uses in proximity to land within the city's urbanized area. It also is to direct non-farm development to other places more appropriate for compact development and integration into the City of Valley City. The sewage lagoon area is not generally the appropriate location for compact urban development. Given the existing use for part of the tract is agriculture and that the previous County zoning designation was Agricultural, assigning Agricultural District status to this tract seems appropriate. The sewage lagoon could be designated as an appropriate use for the tract if deemed fitting and compatible by the Planning and Zoning Commission. The Comprehensive Plan designates this area as a civic use in the future land use plan. It indicates that Civic land use category is for facilities and services provided by the City, County, or a quasi-public organization and is envisioned to include public facilities such as electrical substations, water and wastewater facilities, and other public utility type uses. There is not a direct correlation between zoning districts and the civic land use category, but the existing uses of agriculture and a sewage lagoon are consistent with the future land use plan and the proposed installation of a public safety telecommunications tower is consistent with the Agricultural District requirements because it contemplates the installation of wireless communication facilities within the district.

Findings:

- A. The proposed zoning designation to Agricultural District is consistent with the future land use plan and current land uses.
- B. The proposed zoning designation will support the installation of wireless communication facility.

Recommendation:

Barring additional information presented prior to or at the October 2025 Planning and Zoning Commission, it is recommended the proposed zone change to Agricultural District be approved and recommended for approval to the Board of City Commissioners.

ORDINANCE NO. 1183

An ordinance to amend and reenact Sections 7-01-01 and 7-01-06 of the Valley City Municipal Code related to building permits.

BE IT ORDAINED BY THE BOARD OF CITY COMMISSIONERS OF THE CITY OF VALLEY CITY, BARNES COUNTY, NORTH DAKOTA, PURSUANT TO THE HOME RULE CHARTER OF THE CITY OF VALLEY CITY, NORTH DAKOTA:

Section 1. Section 7-01-01 of the Valley City Municipal Code is amended and reenacted as follows:

Section 7-01-01. - Building permits—Required; non-structural concrete.

The owner, or authorized agent, of any lot or tract within the city, or within area adjoining the city over which the city has zoning jurisdiction, must obtain a written permit from the Building Inspector prior to erecting, constructing, enlarging, altering, repairing, moving, demolishing, or changing the occupancy of any building or structure of any description, or prior to causing any such work to be done.

A building permit shall be required for the addition or enlargement of non-structural concrete, including but not limited to sidewalks, driveways, patios, parking pads, and equipment pads; however, a permit is not required if there is no change to the original footprint of an existing area of concrete.

Section 2. Section 7-01-06 of the Valley City Municipal Code is amended and reenacted as follows:

Section 7-01-06. - Building Code.

The City ~~of Valley City~~ shall follow the North Dakota Building Code with its amendments to the latest International Code unless superseded by the Valley City Municipal Code.

Section 3. Any ordinances of the City of Valley City which are in conflict with this ordinance are hereby repealed.

Section 4. Should any part of this ordinance be declared unconstitutional or invalid, the remaining portion thereof will remain in full force and effect.

Section 5. Effective Date. This ordinance shall be in full force and effect from and after its final passage and approval.

Dave Carlsrud, President
Board of City Commissioners

ATTEST:

Brenda Klein, Finance Director

Introduction and First Reading:
Second Reading, Final Passage, and Effective Date:

ORDINANCE NO. 1184

An ordinance to amend and reenact sections 10-01-03 and subsection 2 of section 10-05-02 of the Valley City Municipal Code related to stormwater permits.

BE IT ORDAINED BY THE BOARD OF CITY COMMISSIONERS OF THE CITY OF VALLEY CITY, BARNES COUNTY, NORTH DAKOTA, PURSUANT TO THE HOME RULE CHARTER OF THE CITY OF VALLEY CITY, NORTH DAKOTA:

Section 1. Section 7-01-01 of the Valley City Municipal Code is amended and reenacted as follows:

Section 10-01-03. Scope.

Every applicant for a building permit, subdivision approval, or a permit to allow land disturbing activities must submit a stormwater management plan to the City Engineer. No building permit, subdivision approval or permit to allow land disturbing activities, shall be issued until approval of the stormwater management plan or a waiver of the approval requirement has been obtained in strict conformance with the provisions of this title.

Exemptions to the requirements of this section include:

1. Freestanding commercial buildings or additions thereto of 500 square feet or less shall not require a stormwater management plan.
2. Owners of parcels of land of 7,000 square feet or less, unless otherwise exempt as provided for in this chapter, can provide at the owners expense the City Engineer's review of the proposed development of such site with a determination as to the necessity of a stormwater management plan. If the engineering review concludes that a stormwater management plan is not needed, the City Engineer shall submit such written findings to the Valley City Building Official. Even if this exemption is applicable, a site survey will still need to be prepared and submitted to the Valley City Building Official. This exemption is not applicable to the development of parcels of land exceeding 7,000 square feet.
3. Any part of a subdivision if a plat of the subdivision has been approved by the Board of City Commissioners and recorded with the Register of Deeds on or before the effective date of this title. ~~A stormwater permit for land disturbing activities on such properties may still be required, however, in accordance with this title;~~
4. Any land disturbing activity involving only the construction of a single-family or a two-family dwelling.
5. A parcel for which a building permit has been approved on or before the effective date of this title;
6. Installation of a fence, sign, telephone, and electric poles and other kinds of posts or poles; or
7. Emergency work to protect life, limb, or property.

~~A stormwater permit for land disturbing activities on exempt properties or activities is still required, however, in accordance with chapter 10-05.~~

The City Engineer may waive any requirement of this title upon making a finding that compliance with the requirement will involve an unnecessary hardship, and the waiver of such requirement will not adversely affect the standards and requirements put forth in chapter 10-05. The City Engineer may require as a condition of the waiver, such dedication or construction, or agreement to dedicate or construct, as may be necessary to adequately meet the said standards and requirements. At the City Engineer's discretion, a waiver request may, or at the request of a City

Commissioner a waiver request shall, be brought before the Board of City Commissioners for consideration, approval and/or denial.

Section 2. Subsection 2 of Section 10-05-02 of the Valley City Municipal Code is amended and reenacted as follows:

2. *Permit application.* All persons subject to meeting the requirements for a mandatory stormwater permit shall complete and file with the City Engineer an application in the form prescribed by the City Engineer and adopted by the Board of City Commissioners. Unless exempt under section 10-01-03, ~~the permit application shall be accompanied by a stormwater management plan as prescribed under chapter 10-02 of this title. In all cases, the City Engineer may require the submission of any relevant data or information in order to make a decision under this chapter. The City Engineer will evaluate the data furnished as part of the stormwater management plan and may require additional information.~~ After evaluation and acceptance of the application~~stormwater management plan~~, the City Engineer may issue a stormwater management permit subject to any terms and conditions deemed necessary.

Section 3. Any ordinances of the City of Valley City which are in conflict with this ordinance are hereby repealed.

Section 4. Should any part of this ordinance be declared unconstitutional or invalid, the remaining portion thereof will remain in full force and effect.

Section 5. Effective Date. This ordinance shall be in full force and effect from and after its final passage and approval.

Dave Carlsrud, President
Board of City Commissioners

ATTEST:

Brenda Klein, Finance Director

Introduction and First Reading:
Second Reading, Final Passage, and Effective Date:

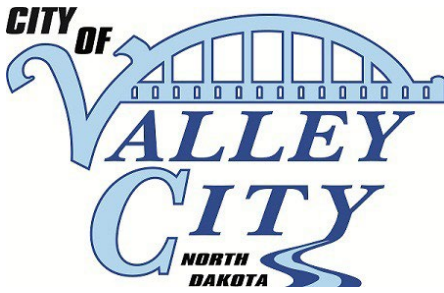

2026

Scheduled Board Meetings

Updated 11.26.2025

COMMISSION MEETINGS

*Finance meetings are held on the third Tuesday at 2:30 p.m. Commission meetings are held on the first and third Tuesday (unless otherwise noted below) at 5:00 p.m.**

JANUARY	6	20	JULY	7	21
FEBRUARY	3	17	AUGUST	4	18
MARCH	3	16*	SEPTEMBER	1	15
APRIL	7	21	OCTOBER	6	20
MAY	4*	19	NOVEMBER	3	17
JUNE	2	16	DECEMBER	1	15

BOARD OF EQUALIZATION TUESDAY, April 14, 2026 at 4 pm

PLANNING & ZONING MEETINGS

Planning & Zoning meetings will be held on the second Tuesday at 4:00 p.m.

PLANNING & ZONING

January	13
February	10
March	10
April	15*
May	12
June	9
July	14
August	11
September	8
October	13
November	10
December	8

** Denotes date change, Meeting was moved due to prior commitments.*

Contract Amendment No. 1
Contract No. 14-UGPR-1004
City of Valley City, North Dakota

UNITED STATES
DEPARTMENT OF ENERGY
WESTERN AREA POWER ADMINISTRATION

Pick-Sloan Missouri Basin Program--Eastern Division

CONTRACT FOR FIRM ELECTRIC SERVICE TO
THE CITY OF VALLEY CITY, NORTH DAKOTA

(General Power Contract Provisions)

UNITED STATES
DEPARTMENT OF ENERGY
WESTERN AREA POWER ADMINISTRATION

Pick-Sloan Missouri Basin Program--Eastern Division

CONTRACT FOR FIRM ELECTRIC SERVICE TO
THE CITY OF VALLEY CITY, NORTH DAKOTA

(General Power Contract Provisions)

<u>Section</u>	<u>Title</u>	<u>Page</u>
1.	Preamble.....	1
2.	Explanatory Recitals.....	1
3.	Agreement.....	2
4.	Term of Amendment	2
5.	Modification of the General Power Contract Provisions Section of the Original Contract.....	2
6.	Original Contract to Remain in Full Force and Effect.....	2
7.	Use of Digital Signatures.....	3
8.	Execution in Counterparts.....	3
	Signatures	4

General Power Contract Provisions dated July 17, 2025

UNITED STATES
DEPARTMENT OF ENERGY
WESTERN AREA POWER ADMINISTRATION

Pick-Sloan Missouri Basin Program--Eastern Division

CONTRACT FOR FIRM ELECTRIC SERVICE TO

THE CITY OF VALLEY CITY, NORTH DAKOTA

(General Power Contract Provisions)

1. PREAMBLE: This Contract Amendment is made on _____,
between the UNITED STATES OF AMERICA, acting through the Western Area Power
Administration, hereinafter called Western, and the CITY OF VALLEY CITY, NORTH
DAKOTA, a municipal corporation duly organized under and by virtue of the laws of the
State of North Dakota, hereinafter called Valley City or Contractor; their successors and
assigns, each sometimes hereinafter called the Party or all sometimes hereinafter
collectively called the Parties, as part of Contract No. 14-UGPR-1004, dated April 9,
2015 (Original Contract), as amended, pursuant to the same authorities as the Original
Contract, and subject to all the provisions as the Original Contract except as herein
amended.

2. EXPLANATORY RECITALS:

2.1 The Parties previously entered into the Original Contract which provides for, among
other things, the sale of firm electric power and energy to Valley City through
December 31, 2050.

2.2 Western's General Power Contract Provisions (GPCP) dated September 1, 2007, made part of the Original Contract, have been revised.

2.3 The Parties want to amend the Original Contract to incorporate the revised GPCP dated July 17, 2025.

2.4 Therefore, this Amendment No. 1 to the Original Contract will modify certain provisions of the Original Contract.

3. AGREEMENT: The Parties agree to the terms and conditions set forth herein.

4. TERM OF AMENDMENT: This Contract Amendment shall become effective on the date of its execution, and shall remain in effect concurrently with the Original Contract and shall terminate coincidentally therewith.

5. MODIFICATION OF THE GENERAL POWER CONTRACT PROVISIONS SECTION OF THE ORIGINAL CONTRACT: Section 18, "General Power Contract Provisions," of the Original Contract is hereby deleted, and the following new Section 18 shall be substituted therefor:

"18. GENERAL POWER CONTRACT PROVISIONS: The GPCP, effective July 17, 2025, attached hereto, are made part of this Contract the same as if they had been expressly set forth herein."

6. ORIGINAL CONTRACT TO REMAIN IN FULL FORCE AND EFFECT: Except as expressly modified by this Contract Amendment, the Original Contract shall remain in

full force and effect, and this Contract Amendment shall be subject to all provisions, except as herein modified, of the Original Contract.

7. USE OF DIGITAL SIGNATURES: The Parties agree that this Contract Amendment may be signed and executed by digital signature in accordance with Western's policy. A digital signature is the same as a handwritten signature and shall be considered valid and acceptable.

8. EXECUTION IN COUNTERPARTS: This Contract Amendment may be executed in any number of counterparts and, upon execution and delivery by each Party, the executed and delivered counterparts together shall have the same force and effect as an original instrument as if all Parties had signed the same instrument. Any signature page of this Contract Amendment may be detached by any counterpart of this Contract Amendment without impairing the legal effect of any signatures thereon, and may be attached to another counterpart of this Contract Amendment identical in form hereto, by having attached to it one or more signature pages.

IN WITNESS WHEREOF, the Parties have caused this Contract Amendment to be executed the day and year first above written.

WESTERN AREA POWER ADMINISTRATION

By _____

Title Vice President of Power Marketing
for Upper Great Plains Region

Address P.O. Box 35800
Billings, MT 59107-5800

(SEAL)

CITY OF VALLEY CITY, NORTH DAKOTA

By _____

Attest:

Title _____

By _____

Address 220 3rd St. NE

Title _____

Valley City, ND 58072

WESTERN AREA POWER ADMINISTRATION
GENERAL POWER CONTRACT PROVISIONS

Page

I. APPLICABILITY.	
1. Applicability	2
II. DELIVERY OF SERVICE PROVISIONS.	
2. Character of Service.....	2
3. Use of Capacity or Energy in Excess of Contract Obligation	2
4. Continuity of Service	2
5. Multiple Points of Delivery.....	2-3
6. Metering.....	3
7. Existence of Transmission Service Contract.....	3
8. Conditions of Transmission Service	4
9. Multiple Points of Delivery Involving Direct and Indirect Deliveries.....	4
10. Construction, Operation, and Maintenance of Contractor’s Power System	4
III. RATES, BILLING, AND PAYMENT PROVISIONS.	
11. Change of Rates	5
12. Minimum Seasonal or Annual Capacity Charge.....	5
13. Billing and Payment.....	5
14. Nonpayment of Bills in Full When Due	5-6
15. Adjustments for Fractional Billing Period	6
16. Adjustments for Curtailments to Firm Service	6
IV. POWER SALES PROVISIONS.	
* 17. Resale of Firm Electric Service (Wholesale Sales for Resale).....	7
18. Distribution Principles	7
19. Contract Subject to Colorado River Compact.....	7
V. FACILITIES PROVISIONS.	
20. Design Approval	7
21. Inspection and Acceptance.....	8
22. As-Built Drawings	8
23. Equipment Ownership Markers	8
24. Third-Party Use of Facilities	8
25. Changes to Western Control Facilities.....	8
26. Modification of Western Facilities.....	9
27. Transmission Rights.....	9
28. Construction and Safety Procedures	9-10
29. Environmental Compliance.....	10
30. Responsibility for Regulated Materials.....	10
VI. OTHER PROVISIONS.	
31. Authorized Representatives of the Parties	10
32. Effect of Section Headings	10
33. Operating Guidelines and Procedures	10
34. Uncontrollable Forces	11
35. Liability.....	11
36. Cooperation of Contracting Parties.....	11
37. Transfer of Interest in the Contract or Change in Preference Status	11-12
38. Choice of Law and Forum	12
39. Waivers	12
40. Notices	12
41. Contingent Upon Appropriations and Authorization	13
42. Covenant Against Contingent Fees.....	13
43. Contract Work Hours and Safety Standards	13
* 44. Compliance with Federal Anti-Discrimination Laws	13
45. Use of Convict Labor.....	13

* Revised July 17, 2025

WESTERN AREA POWER ADMINISTRATION
GENERAL POWER CONTRACT PROVISIONS

I. APPLICABILITY.

1. Applicability.

1.1 These General Power Contract Provisions (Provisions) shall be a part of the contract to which they are attached. In the event these Provisions differ from requirements of the contract, specific terms set forth in the contract shall prevail.

1.2 If the Contractor has member utilities which are either directly or indirectly receiving benefits from the contract, then the Contractor shall require such members to comply with Provisions 10, 17, 18, 19, 29, 30, 36, 43, 44, and 45 of these General Power Contract Provisions.

II. DELIVERY OF SERVICE PROVISIONS.

2. Character of Service.

Electric energy supplied or transmitted under the contract will be three-phase, alternating current, at a nominal frequency of sixty (60) hertz (cycles per second).

3. Use of Capacity or Energy in Excess of Contract Obligation.

The Contractor is not entitled to use Federal power, energy, or capacity in amounts greater than the Western contract delivery obligation in effect for each type of service provided for in the contract except with the approval of Western. Unauthorized overruns of contract delivery obligations shall be subject to charges specified in the contract or the applicable rate schedules. Overruns shall not establish any continuing right thereto and the Contractor shall cease any overruns when requested by Western, or in the case of authorized overruns, when the approval expires, whichever occurs first. Nothing in the contract shall obligate Western to increase any delivery obligation. If additional power, energy, or capacity is not available from Western, the responsibility for securing additional power, energy, or capacity shall rest wholly with the Contractor.

4. Continuity of Service.

Electric service will be supplied or transmitted continuously except for: (1) fluctuations, interruptions, or reductions due to uncontrollable forces, as defined in Provision 34 (Uncontrollable Forces) herein, (2) fluctuations, interruptions, or reductions due to operation of devices installed for power system protection; and (3) temporary fluctuations, interruptions, or reductions, which, in the opinion of the party supplying the service, are necessary or desirable for the purposes of maintenance, repairs, replacements, installation of equipment, or investigation and inspection. The party supplying service, except in case of emergency, will give the party to whom service is being provided reasonable advance notice of such temporary interruptions or reductions and will remove the cause thereof with diligence.

5. Multiple Points of Delivery.

When electric service is supplied at or transmitted to two or more points of delivery under the same rate schedule, said rate schedule shall apply separately to the service supplied at or transmitted to each point of

delivery; Provided, That where the meter readings are considered separately, and during abnormal conditions, the Contractor's system is interconnected between points of delivery such that duplication of metered power is possible, the meter readings at each affected point of delivery will be adjusted to compensate for duplication of power demand recorded by meters at alternate points of delivery due to abnormal conditions which are beyond the Contractor's control or temporary conditions caused by scheduled outages.

6. Metering.

6.1 The total electric power and energy supplied or transmitted under the contract will be measured by metering equipment to be furnished and maintained by Western, a designated representative of Western, or where situations deem it appropriate as determined by Western, by the Contractor or its agent(s). In the event metering equipment is furnished and maintained by the Contractor or its agent(s) and the equipment is used for billing and other accounting purposes by Western, the Contractor shall ensure that the metering equipment complies with applicable metering policies established by Western.

6.2 Meters shall be secured by appropriate security measures and meters shall not be accessed except when the meters are to be inspected, tested, adjusted, or repaired. Representatives of affected parties shall be afforded reasonable opportunity to be present upon such occasions. Metering equipment shall be inspected and tested each year by the party responsible for meter maintenance, unless a different test interval is determined in accordance with good utility practices by an applicable regional metering policy, or as agreed upon by the parties. Meters shall also be tested at any reasonable time upon request by a party hereto, or by an affected supplemental power supplier, transmission agent, or control area operator. Any metering equipment found to be damaged, defective, or inaccurate shall be repaired and readjusted or replaced by the party responsible for meter maintenance as soon as practicable. Meters found with security breaches shall be tested for tampering and, if appropriate, meter readings shall be adjusted by Western pursuant to Provision 6.3 below.

6.3 Except as otherwise provided in Provision 6.4 hereof, should any meter that is used by Western for billing or other accounting purposes fail to register accurately, the electric power and energy supplied or transmitted during the period of failure to register accurately, shall, for billing purposes, be estimated by Western from the best available information.

6.4 If inspections and tests of a meter used by Western for billing or other accounting purposes disclose an error exceeding 2 percent, or a lesser range in error as agreed upon by the parties, then a correction based upon the inaccuracy found shall be made to the service records for the period of inaccuracy as determined by Western. If the period of inaccuracy cannot be determined, the inaccuracy shall be assumed to have existed during the entire monthly billing period immediately preceding the billing period in which the inspection or test was made and the resulting correction shall be made accordingly.

6.5 Any correction in billing or other accounting information that results from a correction in meter records shall be made in a subsequent monthly bill rendered by Western to the Contractor. Payment of such bill shall constitute full adjustment of any claim between the parties arising out of inaccurate metering equipment.

7. Existence of Transmission Service Contract.

If the contract provides for Western to furnish services using the facilities of a third party, the obligation of Western shall be subject to and contingent upon the existence of a transmission service contract granting Western rights to use such facilities. If Western acquires or constructs facilities which would enable it to furnish direct service to the Contractor, Western, at its option, may furnish service over its own facilities.

8. Conditions of Transmission Service.

8.1 When the electric service under the contract is furnished by Western over the facilities of others by virtue of a transmission service arrangement, the power and energy will be furnished at the voltage available and under the conditions which exist from time to time on the transmission system over which the service is supplied.

8.2 Unless otherwise provided in the contract or applicable rate schedule, the Contractor shall maintain a power factor at each point of delivery from Western's transmission agent as required by the transmission agent.

8.3 Western will endeavor to inform the Contractor from time to time of any changes planned or proposed on the system over which the service is supplied, but the costs of any changes made necessary in the Contractor's system, because of changes or conditions on the system over which the service is supplied, shall not be a charge against or a liability of Western.

8.4 If the Contractor, because of changes or conditions on the system over which service under the contract is supplied, is required to make changes on its system at its own expense in order to continue receiving service under the contract, then the Contractor may terminate service under the contract upon not less than sixty (60) days written notice given to Western prior to making such changes, but not thereafter.

8.5 If Western notifies the Contractor that electric service provided for under the contract cannot be delivered to the Contractor because of an insufficiency of capacity available to Western in the facilities of others over which service under the contract is supplied, then the Contractor may terminate service under the contract upon not less than sixty (60) days written notice given to Western prior to the date on which said capacity ceases to be available to Western, but not thereafter.

9. Multiple Points of Delivery Involving Direct and Indirect Deliveries.

When Western has provided line and substation capacity under the contract for the purpose of delivering electric service directly to the Contractor at specified direct points of delivery and also has agreed to absorb transmission service allowance or discounts for deliveries of energy over other system(s) to indirect points of delivery and the Contractor shifts any of its load served under the contract from direct delivery to indirect delivery, Western will not absorb the transmission service costs on such shifted load until the unused capacity, as determined solely by Western, available at the direct delivery points affected is fully utilized.

10. Construction, Operation, and Maintenance of Contractor's Power System.

The Contractor shall, and, if applicable, shall require each of its members or transmission agents to construct, operate, and maintain its power system in a manner which, as determined by Western, will not interfere with the operation of the system of Western or its transmission agents over which electric services are furnished to the Contractor under the contract, and in a manner which will coordinate with the protective relaying and other protective arrangements of the system(s) of Western or Western's transmission agents. Western may reduce or discontinue furnishing services to the Contractor if, after notice by Western, the Contractor fails or refuses to make such changes as may be necessary to eliminate an unsatisfactory condition on the Contractor's power system which is determined by Western to interfere significantly under current or probable conditions with any service supplied from the power system of Western or from the power system of a transmission agent of Western. Such a reduction or discontinuance of service will not relieve the Contractor of liability for any minimum charges provided for in the contract during the time said services are reduced or discontinued. Nothing in this Provision shall be construed to render Western liable in any manner for any claims, demands, costs, losses, causes of action, damages, or liability of any kind or nature arising out of or resulting from the construction, operation, or maintenance of the Contractor's power system.

III. RATES, BILLING, AND PAYMENT PROVISIONS.

11. Change of Rates.

Rates applicable under the contract shall be subject to change by Western in accordance with appropriate rate adjustment procedures. If at any time the United States promulgates a rate changing a rate then in effect under the contract, it will promptly notify the Contractor thereof. Rates shall become effective as to the contract as of the effective date of such rate. The Contractor, by written notice to Western within ninety (90) days after the effective date of a rate change, may elect to terminate the service billed by Western under the new rate. Said termination shall be effective on the last day of the billing period requested by the Contractor not later than two (2) years after the effective date of the new rate. Service provided by Western shall be paid for at the new rate regardless of whether the Contractor exercises the option to terminate service.

12. Minimum Seasonal or Annual Capacity Charge.

When the rate in effect under the contract provides for a minimum seasonal or annual capacity charge, a statement of the minimum capacity charge due, if any, shall be included in the bill rendered for service for the last billing period of the service season or contract year as appropriate, adjusted for increases or decreases in the contract rate of delivery and for the number of billing periods during the year or season in which service is not provided. Where multiple points of delivery are involved and the contract rate of delivery is stated to be a maximum aggregate rate of delivery for all points, in determining the minimum seasonal or annual capacity charge due, if any, the monthly capacity charges at the individual points of delivery shall be added together.

13. Billing and Payment.

13.1 Western will normally issue bills to the Contractor for services furnished during the preceding month within ten (10) days after the end of the billing period.

13.2 If Western is unable to issue timely monthly bill(s), Western may elect to render estimated bill(s). Such estimated bill(s) shall be subject to the same payment provisions as final bill(s), and any applicable adjustments will be shown on a subsequent monthly bill.

13.3 Payments of bills issued by Western are due and payable by the Contractor before the close of business on the twentieth (20th) calendar day after the date of issuance of each bill or the next business day thereafter if said day is a Saturday, Sunday, or Federal holiday. Bills shall be considered paid when payment is received by Western. Bills will be paid electronically or via the Automated Clearing House method of payment unless a written request to make payments by mail is submitted by the Contractor and approved by Western. Should Western agree to accept payments by mail, these payments will be accepted as timely and without assessment of the charge provided for in Provision 14 (Nonpayment of Bills in Full When Due) if a United States Post Office first class mail postmark indicates the payment was mailed at least three (3) calendar days before the due date.

13.4 The parties agree that net billing procedures will be used for payments due Western by the Contractor and for payments due the Contractor by Western for the sale or exchange of electric power and energy, use of transmission facilities, operation and maintenance of electric facilities, and other services. Payments due one party in any month shall be offset against payments due the other party in such month, and the resulting net balance shall be paid to the party in whose favor such balance exists. The parties shall exchange such reports and information that either party requires for billing purposes. Net billing shall not be used for any amounts due which are in dispute.

14. Nonpayment of Bills in Full When Due.

14.1 Bills not paid in full by the Contractor by the due date specified in Provision 13 (Billing and

Payment) hereof shall bear a charge of five hundredths percent (0.05%) of the principal sum unpaid for each day payment is delinquent, to be added until the amount due is paid in full. Western will also assess a fee of twenty-five dollars (\$25.00) for processing a late payment. Payments received will first be applied to the charges for late payment assessed on the principal and then to payment of the principal.

14.2 Western shall have the right, upon not less than fifteen (15) days advance written notice, to discontinue furnishing the services specified in the contract for nonpayment of bills in full when due, and to refuse to resume such services so long as any part of the amount due remains unpaid. Such a discontinuance of service will not relieve the Contractor of liability for minimum charges during the time service is so discontinued. The rights reserved to Western herein shall be in addition to all other remedies available to Western either by law or in equity, for the breach of any of the terms hereof.

15. Adjustments for Fractional Billing Period.

The demand or capacity charge and minimum charges shall each be proportionately adjusted when fractional billing periods are applicable under this contract. A fractional billing period can occur: 1) at the beginning or end of electric service; 2) at the beginning or end of irrigation pumping service each year; 3) for a fractional billing period under a new rate schedule; or 4) for fractional periods due to withdrawals of electric services. The adjustment will be made based on the ratio of the number of hours that electric service is available to the Contractor in such fractional billing period, to the total number of hours in the billing period involved. Energy billing shall not be affected by fractional billing periods.

16. Adjustments for Curtailments to Firm Service.

16.1 Billing adjustments will be made if firm electric service is interrupted or reduced because of conditions on the power system of the United States for periods of one (1) hour or longer in duration each. Billing adjustments will not be made when such curtailment of electric service is due to a request by the Contractor or a discontinuance of electric service by Western pursuant to Provision 14 (Nonpayment of Bills In Full When Due). For purposes of billing adjustments under this Provision, the term power system of the United States shall include transmission facilities used under contract but not owned by the United States.

16.2 The total number of hours of curtailed firm electric service in any billing period shall be determined by adding: (1) the sum of the number of hours of interrupted electric service to (2) the product, of each reduction, of: the number of hours reduced electric service and the percentage by which electric service was reduced below the delivery obligation of Western at the time of each said reduction of electric service. The demand or capacity charge and applicable minimum charges shall each be proportionately adjusted in the ratio that the total number of hours of electric service determined to have been curtailed bears to the total number of hours in the billing period involved.

16.3 The Contractor shall make written claim within thirty (30) days after receiving the monthly bill, for adjustment on account of any curtailment of firm electric service, for periods of one (1) hour or longer in duration each, alleged to have occurred that is not reflected in said bill. Failure to make such written claim, within said thirty-day (30-day) period, shall constitute a waiver of said claim. All curtailments of electric service, which are due to conditions on the power system of the United States, shall be subject to the terms of this Provision; Provided, That withdrawal of power and energy under the contract shall not be considered a curtailment of electric service.

IV. POWER SALES PROVISIONS.

17. Resale of Firm Electric Service (Wholesale Sales for Resale).

17.1 The Contractor shall not sell any firm electric power or energy supplied under the contract to any electric utility customer of the Contractor for resale by that utility customer; Provided, That the Contractor may sell the electric power and energy supplied under the contract to its members on condition that said members not sell any of said power and energy to any customer of the member for resale by that customer.

17.2 Contractors receiving environmental attributes associated with any firm electric power or energy allocated under the contract may use, dispose of, transfer, or resell such environmental attributes in accordance with good utility practice.

18. Distribution Principles.

The Contractor agrees that the benefits of firm electric power or energy supplied under the contract shall be made available to its consumers at rates that are established at the lowest possible level consistent with sound business principles, and that these rates will be established in an open and public manner. The Contractor further agrees that it will identify the costs of firm electric power or energy supplied under the contract and power from other sources to its consumers upon request. The Contractor will demonstrate compliance with the requirements of this Provision to Western upon request.

19. Contract Subject to Colorado River Compact.

Where the energy sold under the contract is generated from waters of the Colorado River system, the contract is made upon the express condition and with the express covenant that all rights under the contract shall be subject to and controlled by the Colorado River Compact approved by Section 13 (a) of the Boulder Canyon Project Act of December 21, 1928, 43 U.S.C. §§ 617a-e, and the parties to the contract shall observe and be subject to and controlled by said Colorado River Compact in the construction, management, and operation of the dams, reservoirs, and powerplants from which electrical energy is to be furnished by Western to the Contractor under the contract, and in the storage, diversion, delivery, and use of water for the generation of electrical energy to be delivered by Western to the Contractor under the contract.

V. FACILITIES PROVISIONS.

20. Design Approval.

All facilities, construction, and installation by the Contractor pursuant to the contract shall be subject to the approval of Western. Facilities interconnections shall normally conform to Western's current "General Requirements for Interconnection," in effect upon the signing of the contract document providing for each interconnection, copies of which are available from Western. At least ninety (90) days, unless otherwise agreed, prior to the date the Contractor proposes to commence construction or to incur an obligation to purchase facilities to be installed pursuant to the contract, whichever date is the earlier, the Contractor shall submit, for the approval of Western, detailed designs, drawings, and specifications of the facilities the Contractor proposes to purchase, construct, and install. The Contractor assumes all risks for construction commenced or obligations to purchase facilities incurred prior to receipt of approval from Western. Western review and approval of designs and construction work in no way implies that Western is certifying that the designs meet the Contractor's needs.

21. Inspection and Acceptance.

Western shall have the right to inspect the materials and work furnished by the Contractor, its agents, employees, and subcontractors pursuant to the contract. Such inspections shall be at reasonable times at the work site. Any materials or work that Western determines is defective or not in accordance with designs, drawings, and specifications, as approved by Western, shall be replaced or modified, as directed by Western, at the sole expense of the Contractor before the new facilities are energized.

22. As-Built Drawings.

Within a reasonable time, as determined by Western, after the completion of construction and installation of facilities pursuant to the contract, the Contractor shall submit to Western marked as-built prints of all Western drawings affected by changes made pursuant to the contract and reproducible drawings the Contractor has prepared showing facilities of Western. The Contractor's drawings of Western facilities shall use drawing title blocks, drawing numbers, and shall be prepared in accordance with drafting standards all as approved by Western. Western may prepare, revise, or complete said drawings and bill the Contractor if the Contractor fails to provide such drawings to Western within a reasonable time as determined by Western.

23. Equipment Ownership Markers.

23.1 The Contractor shall identify all movable equipment and, to the extent agreed upon by the parties, all other salvageable facilities constructed or installed on the United States right-of-way or in Western substations pursuant to the contract which are owned by the Contractor, by permanently affixing thereto suitable markers clearly identifying the Contractor as the owner of said equipment and facilities.

23.2 If requested by the Contractor, Western shall identify all movable equipment and, to the extent agreed upon by the parties, all other salvageable facilities constructed or installed on the Contractor's right-of-way or in the Contractor's substations pursuant to the contract which are owned by the United States, by permanently affixing thereto suitable markers clearly identifying the United States as the owner of said equipment and facilities.

24. Third-Party Use of Facilities.

The Contractor shall notify Western of any proposed system change relating to the facilities governed by the contract or allowing third-party use of the facilities governed by the contract. If Western notifies the Contractor that said system change will, as solely determined by Western, adversely affect the operation of Western's system the Contractor shall, at no cost to Western, provide a solution to said adverse effect acceptable to Western.

25. Changes to Western Control Facilities.

If at any time during the term of the contract, Western determines that changes or additions to control, relay, or communications facilities are necessary to maintain the reliability or control of Western's transmission system, and said changes or additions are entirely or partially required because of the Contractor's equipment installed under the contract, such changes or additions shall, after consultation with the Contractor, be made by Western with all costs or a proportionate share of all costs, as determined by Western, to be paid by the Contractor. Western shall notify the Contractor in writing of the necessary changes or additions and the estimated costs to be paid by the Contractor. If the Contractor fails to pay its share of said estimated costs, Western shall have the right, after giving sixty (60) days' written notice to the Contractor, to terminate the applicable facility installation provisions to the contract and require the removal of the Contractor's facilities.

26. Modification of Western Facilities.

Western reserves the right, at any time, to modify its facilities. Western shall keep the Contractor informed of all planned modifications to Western facilities which impact the facilities installation pursuant to the contract. Western shall permit the Contractor to change or modify its facilities, in a manner satisfactory to and at no cost or expense to Western, to retain the facilities interconnection pursuant to the contract. At the Contractor's option, Western shall cooperate with the Contractor in planning alternate arrangements for service which shall be implemented at no cost or expense to Western. The Contractor and Western shall modify the contract, as necessary, to conform to the new facilities arrangements.

27. Transmission Rights.

If the contract involves an installation which sectionalizes a Western transmission line, the Contractor hereby agrees to provide a transmission path to Western across such sectionalizing facilities at no cost or expense to Western. Said transmission path shall be at least equal, in terms of capacity and reliability, to the path in the Western transmission line prior to the installation pursuant to the contract.

28. Construction and Safety Procedures.

28.1 The Contractor hereby acknowledges that it is aware of the hazards inherent in high-voltage electric lines and substations, and hereby assumes full responsibility at all times for the adoption and use of necessary safety measures required to prevent accidental harm to personnel engaged in the construction, inspection, testing, operation, maintenance, replacement, or removal activities of the Contractor pursuant to the contract. The Contractor and the authorized employees, agents, and subcontractors of the Contractor shall comply with all applicable safety laws and building and construction codes, including the provisions of Chapter 1 of the Power System Operations Manual, entitled Power System Switching Procedure, and the Occupational Safety and Health Administration regulations, Title 29 C.F.R. §§ 1910 and 1926, as amended or supplemented. In addition to the safety program required herein, upon request of the United States, the Contractor shall provide sufficient information to demonstrate that the Contractor's safety program is satisfactory to the United States.

28.2 The Contractor and its authorized employees, agents, and subcontractors shall familiarize themselves with the location and character of all the transmission facilities of Western and interconnections of others relating to the work performed by the Contractor under the contract. Prior to starting any construction, installation, or removal work, the Contractor shall submit a plan of procedure to Western which shall indicate the sequence and method of performing the work in a safe manner. No work shall be performed by the Contractor, its employees, agents, or subcontractors until written authorization to proceed is obtained from Western.

28.3 At all times when the Contractor, its employees, agents, or subcontractors are performing activities of any type pursuant to the contract, such activities shall be under supervision of a qualified employee, agent, or subcontractor of the Contractor who shall be authorized to represent the Contractor in all matters pertaining to the activity being performed. The Contractor and Western will keep each other informed of the names of their designated representatives at the site.

28.4 Upon completion of its work, the Contractor shall remove from the vicinity of the right-of-way of the United States all buildings, rubbish, used materials, concrete forms, and other like material belonging to the Contractor or used under the Contractor's direction, and in the event of failure to do so the same may be removed by Western at the expense of the Contractor.

28.5 In the event the Contractor, its employees, agents, or subcontractors fail to comply with any requirement of this Provision, or Provision 21 (Inspection and Acceptance) herein, Western or an authorized representative may issue an order to stop all or any part of the work until such time as the Contractor demonstrates

compliance with the provision at issue. The Contractor, its employees, agents, or subcontractors shall make no claim for compensation or damages resulting from such work stoppage.

29. Environmental Compliance.

Facilities installed under the contract by any party shall be constructed, operated, maintained, replaced, transported, and removed subject to compliance with all applicable laws, including but not limited to the National Historic Preservation Act of 1966, 16 U.S.C. §§ 470x-6, the National Environmental Policy Act of 1969, 42 U.S.C. §§ 4321-4347, the Endangered Species Act of 1973, 16 U.S.C. §§ 1531-1544, and the Archaeological Resources Protection Act of 1979, 16 U.S.C. §§ 470aa-470mm, and the regulations and executive orders implementing these laws, as they may be amended or supplemented, as well as any other existing or subsequent applicable laws, regulations, and executive orders.

30. Responsibility for Regulated Materials.

When either party owns equipment containing regulated material located on the other party's substation, switchyard, right-of-way, or other property, the equipment owner shall be responsible for all activities related to regulated materials in such equipment that are necessary to meet the requirements of the Toxic Substances Control Act, 15 U.S.C. §§ 2601-2692, the Resource Conservation and Recovery Act, 42 U.S.C. §§ 6901-6992k, the Comprehensive Environmental Response, Compensation, and Liability Act of 1980, 42 U.S.C. §§ 9601-9675, the Oil Pollution Act of 1990, 33 U.S.C. §§ 2702-2761, the Clean Water Act, 33 U.S.C. §§ 1251-1387, the Safe Drinking Water Act, 42 U.S.C. §§ 300f-j26, and the regulations and executive orders implementing these laws, as they may be amended or supplemented, and any other existing or subsequent applicable laws, regulations, and executive orders. Each party shall label its equipment containing regulated material in accordance with appropriate laws and regulations. If the party owning the equipment does not perform activities required under appropriate laws and regulations within the time frame specified therein, the other party may perform or cause to be performed the required activities after notice to and at the sole expense of the party owning the equipment.

VI. OTHER PROVISIONS.

31. Authorized Representatives of the Parties.

Each party to the contract, by written notice to the other, shall designate the representative(s) who is (are) authorized to act in its behalf with respect to those matters contained in the contract which are the functions and responsibilities of the authorized representatives of the parties. Each party may change the designation of its authorized representative(s) upon oral notice given to the other, confirmed promptly by written notice.

32. Effect of Section Headings.

Section headings or Provision titles appearing in the contract or these General Power Contract Provisions are inserted for convenience only and shall not be construed as interpretations of text.

33. Operating Guidelines and Procedures.

The parties to the contract may agree upon and put into effect from time to time, such other written guidelines and procedures as may be required in order to establish the methods of operation of the power system to be followed in the performance of the contract.

34. Uncontrollable Forces.

Neither party to the contract shall be considered to be in default in performance of any of its obligations under the contract, except to make payment as specified in Provision 13 (Billing and Payment) herein, when a failure of performance shall be due to an uncontrollable force. The term “uncontrollable force” means any cause beyond the control of the party affected, including but not restricted to, failure of or threat of failure of facilities, flood, earthquake, storm, fire, lightning, epidemic, war, riot, civil disturbance or disobedience, labor dispute, labor or material shortage, sabotage, restraint by court order or public authority and action or nonaction by, or failure to obtain the necessary authorizations or approvals from, any governmental agency or authority, which by exercise of due diligence such party could not reasonably have been expected to avoid and which by exercise of due diligence it shall be unable to overcome. Nothing contained herein shall be construed to require a party to settle any strike or labor dispute in which it may be involved. Either party rendered unable to fulfill any of its obligations under the contract by reason of an uncontrollable force shall give prompt written notice of such fact to the other party and shall exercise due diligence to remove such inability with all reasonable dispatch.

35. Liability.

35.1 The Contractor hereby agrees to indemnify and hold harmless the United States, its employees, agents, or contractors from any loss or damage and from any liability on account of personal injury, death, or property damage, or claims for personal injury, death, or property damage of any nature whatsoever and by whomsoever made arising out of the Contractors’, its employees’, agents’, or subcontractors’ construction, operation, maintenance, or replacement activities under the contract.

35.2 The United States is liable only for negligence on the part of its officers and employees in accordance with the Federal Tort Claims Act, 28 U.S.C. §§ 1346(b), 1346(c), 2401(b), 2402, 2671, 2672, 2674-2680, as amended or supplemented.

36. Cooperation of Contracting Parties.

If, in the operation and maintenance of their respective power systems or electrical equipment and the utilization thereof for the purposes of the contract, it becomes necessary by reason of any emergency or extraordinary condition for either party to request the other to furnish personnel, materials, tools, and equipment for the accomplishment thereof, the party so requested shall cooperate with the other and render such assistance as the party so requested may determine to be available. The party making such request, upon receipt of properly itemized bills from the other party, shall reimburse the party rendering such assistance for all costs properly and reasonably incurred by it in such performance, including administrative and general expenses, such costs to be determined on the basis of current charges or rates used in its own operations by the party rendering assistance. Issuance and payment of bills for services provided by Western shall be in accordance with Provisions 13 (Billing and Payment) and 14 (Nonpayment of Bills in Full When Due) herein. Western shall pay bills issued by the Contractor for services provided as soon as the necessary vouchers can be prepared which shall normally be within twenty (20) days.

37. Transfer of Interest in Contract or Change in Preference Status.

37.1 No voluntary transfer of the contract or of the rights of the Contractor under the contract shall be made without the prior written approval of the Administrator of Western. Any voluntary transfer of the contract or of the rights of the Contractor under the contract made without the prior written approval of the Administrator of Western may result in the termination of the contract; Provided, That the written approval of the Administrator shall not be unreasonably withheld; Provided further, That if the Contractor operates a project financed in whole or in part by the Rural Utilities Service, the Contractor may transfer or assign its interest in the contract to the Rural Utilities Service or any other department or agency of the Federal Government without such prior written approval; Provided further, That any successor to or assignee of the rights of the Contractor, whether by voluntary transfer, judicial sale,

foreclosure sale, or otherwise, shall be subject to all the provisions and conditions of the contract to the same extent as though such successor or assignee were the original Contractor under the contract; and, Provided further, That the execution of a mortgage or trust deed, or judicial or foreclosure sales made thereunder, shall not be deemed voluntary transfers within the meaning of this Provision.

37.2 The Contractor shall maintain its status as an entity eligible for preference in Western's sale of Federal power pursuant to Reclamation law, as amended and supplemented.

37.3 Western shall give the Contractor written notice of Western's proposed determination that the Contractor has violated Provision 37.1 and Western's proposed action in response to the violation.

37.4 The Contractor shall have 120 days after receipt of Western's notice provided under Provision 37.3 to submit a written response to Western. The Contractor may also make an oral presentation to the Administrator during this 120-day period.

37.5 At any time during this process, the Contractor and Western may agree upon corrective action to resolve Western's proposed determination that the Contractor is in violation of Provision 37.1.

37.6 Within 30 days of receipt of the Contractor's written response provided under Provision 37.4, Western will notify the Contractor in writing of its final decision. The Administrator's written notice will include the intended action, the effective date thereof, and the reasons for taking the intended action. Implementation of the Administrator's action shall take place no earlier than 60 days from the Contractor's receipt of such notice.

37.7 Any successor to Western shall be subject to all the provisions and conditions of the contract to the same extent as though such successor were an original signatory to the contract.

37.8 Nothing in this Provision shall preclude any right to judicial review available to the Contractor under Federal law.

38. Choice of Law and Forum.

Federal law shall control the obligations and procedures established by this contract and the performance and enforcement thereof. The forum for litigation arising from this contract shall exclusively be a Federal court of the United States, unless the parties agree to pursue alternative dispute resolution.

39. Waivers.

Any waivers at any time by either party to the contract of its rights with respect to a default or any other matter arising under or in connection with the contract shall not be deemed a waiver with respect to any subsequent default or matter.

40. Notices.

Any notice, demand, or request specifically required by the contract or these Provisions to be in writing shall be considered properly given when delivered in person or sent by postage prepaid registered or certified mail, commercial delivery service, facsimile, electronic, prepaid telegram, or by other means with prior agreement of the parties, to each party's authorized representative at the principal offices of the party. The designation of the person to be notified may be changed at any time by similar notice. Where facsimile or electronic means are utilized for any communication covered by this Provision, the sending party shall keep a contemporaneous record of such communications and shall verify receipt by the other party.

41. Contingent Upon Appropriations and Authorization.

41.1 Where activities provided for in the contract extend beyond the current fiscal year, continued expenditures by the United States are contingent upon Congress making the necessary appropriations required for the continued performance of the United States' obligations under the contract. In case such appropriation is not made, the Contractor hereby releases the United States from its contractual obligations and from all liability due to the failure of Congress to make such appropriation.

41.2 In order to receive and expend funds advanced from the Contractor necessary for the continued performance of the obligations of the United States under the contract, additional authorization may be required. In case such authorization is not received, the Contractor hereby releases the United States from those contractual obligations and from all liability due to the lack of such authorization.

42. Covenant Against Contingent Fees.

The Contractor warrants that no person or selling agency has been employed or retained to solicit or secure the contract upon an agreement or understanding for a commission, percentage, brokerage, or contingent fee, excepting bona fide employees or bona fide established commercial or selling agencies maintained by the Contractor for the purpose of securing business. For breach or violation of this warranty, Western shall have the right to annul the contract without liability or in its discretion to deduct from the contract price or consideration the full amount of such commission, percentage, brokerage, or contingent fee.

43. Contract Work Hours and Safety Standards.

The contract, to the extent that it is of a character specified in Section 103 of the Contract Work Hours and Safety Standards Act (Act), 40 U.S.C. § 3701, as amended or supplemented, is subject to the provisions of the Act, 40 U.S.C. §§ 3701-3708, as amended or supplemented, and to regulations promulgated by the Secretary of Labor pursuant to the Act.

44. Compliance with Federal Anti-Discrimination Laws.

44.1 The Contractor shall comply with all applicable Federal anti-discrimination laws. Compliance with applicable Federal anti-discrimination laws is material to eligibility for and payment under this contract for purposes of 31 U.S.C. 3729(b)(4).

44.2 By executing this agreement, the Contractor certifies that, to the best of its knowledge and belief, it does not operate programs promoting diversity, equity, and inclusion that violate any applicable Federal anti-discrimination laws. "Program promoting diversity, equity, and inclusion" means a program whose purpose is to promote preferences based on race, color, religion, sex, or national origins, such as in training or hiring.

44.3 Indian Tribes and tribal organizations may apply Indian preference to the extent permitted by Federal law.

45. Use of Convict Labor.

The Contractor agrees not to employ any person undergoing sentence of imprisonment in performing the contract except as provided by 18 U.S.C. § 3622(c), as amended or supplemented, and Executive Order No. 11755, 39 Fed. Reg. 779 (1973), as amended or supplemented.

Western Area Power Administration
Upper Great Plains Region (UGPR)
Renewable Energy Certificate Program Principles

1. Customers that receive Pick-Sloan Missouri Basin Program -- Eastern Division Firm Electric Service (FES) allocations and take delivery of firm energy are eligible to obtain Renewable Energy Certificates (RECs) under the Upper Great Plains Region (UGPR) REC Program (Program). Customers that receive FES allocations and take delivery of firm energy will be allocated RECs under the Program and will herein be called Participants. Peaking power contracts are excluded from the Program.
2. RECs will be allocated annually based upon the energy associated with each customer's FES allocation. Energy generated from U.S. Bureau of Reclamation (Reclamation) and the U.S. Army Corps of Engineers (CORPS) hydropower facilities during the preceding calendar year will be allocated in the ratio of one (1) REC to one (1) megawatt hour (MWh) generated. Purchase Power, including Purchase Power from renewable resources, is not part of the Program.
3. Generation from the hydropower facilities fluctuates each year. Participants will be allocated RECs on a proportionate share of the actual generation from the hydropower dams in UGPR, not to exceed each Participant's firm power allocation.
 - a. Should generation be less than the sum of the Participants' firm power allocations, Participants will receive a proportionate share of RECs for actual generation from each hydropower dam in UGPR that year. This amount may be less than the Participant's firm power allocation.
 - b. Should generation be greater than the sum of the Participants' firm power allocations, WAPA may, at its sole discretion, allocate the excess RECs to Participants on a proportionate share to offset lesser generation years.
 - c. The equation for determining each Participant's allocated RECs shall be the total available RECs multiplied by each Participant's percentage of firm energy, then rounded down to the last whole MWh.
 - d. Allocated RECs cannot exceed the Participant's firm power allocation.
4. WAPA offers these RECs as an additional benefit of the firm energy delivered to Participants and considers RECs an environmental attribute of the energy generated by Reclamation and the CORPS. RECs are subject to the same terms and conditions as the Participant's FES Contract.
5. WAPA makes no warranties or guarantees that the RECs qualify for or meet any Federal, state, or local renewable energy standards. It is the Participant's responsibility to verify whether RECs qualify for Federal, state, or other renewable energy standard requirements.
6. Tracking and Management of RECs: UGPR uses the Midwest Renewable Energy Tracking System (M-RETS) to track each Participant's annual proportionate share of RECs from each of UGPR's eight hydropower dams.
 - a. Yellowtail Dam was initially registered by WAPA's Rocky Mountain Region in a separate tracking system, Western Renewable Energy Generation Information System (WREGIS). UGPR's portion of the Yellowtail Dam generation RECs (50 percent)

are imported from WREGIS to M-RETS annually. RECs originating from the Yellowtail Dam may not be compatible for exporting to tracking system accounts outside of M-RETS due to system incompatibility (i.e., M-RETS to North American Renewables Registry).

7. WAPA shall hold each Participant's RECs in separate subaccounts in M-RETS, unless other arrangements have been requested. WAPA will not sell or retire RECs for Participants.
8. Participants may request other arrangements for the tracking and management of their RECs which include: 1) managing their own RECs in M-RETS; 2) managing their own RECs in a tracking system compatible with receiving exports from M-RETS (compatible tracking system); or 3) designating another entity (Designated Entity), approved by WAPA, to manage the Participant's RECs in M-RETS or a compatible tracking system on the Participant's behalf.
 - a. A separate contract with WAPA is required to transfer or export RECs to Participants and Designated Entities.
 - b. Participants and/or their Designated Entity are responsible for:
 - i. tracking, managing, transferring, exporting, retiring, and selling RECs and paying any associated fees.
 - ii. ensuring the double counting of RECs does not occur, and WAPA disclaims any responsibility therefor.
 - iii. ensuring established REC Program Principles are followed, including but not limited to, following the terms of the FES Contract.
 - c. Upon request and receipt of associated fees, WAPA will transfer or export RECs to the Participant or Designated Entity in accordance with the separate contract as mentioned in 8a above.
 - d. The Participant's and Designated Entity's right to claim, hold, resell, or otherwise use RECs is only for the term of the Participant's underlying applicable firm power contract.
9. RECs associated with Project Use Power Contracts will be allocated in the same manner as FES Contracts.
10. UGPR REC Program Costs:
 - a. Costs for WAPA to administer the program and costs for the initial issuance of RECs will be incorporated into the UGPR firm power rate.
 - b. Costs associated with transferring and/or exporting RECs to a Participant's or Designated Entity's account, and other costs as described in Principle 8b above, are the responsibility of the Participant and/or Designated Entity.
 - c. Advanced funding will be required.
11. WAPA reserves the right to suspend or terminate the Program upon reasonable advance written notice to Participants. Though WAPA may solicit input, it can change these Principles, without notice, at its discretion.
12. Participant shall indemnify WAPA and hold it harmless from any claims related to the use, management, or resale of RECs.

Approved: _____ Date: _____

Contract No. 25-UGPR-95
City of Valley City, North Dakota
Missouri Basin Municipal Power
Agency d.b.a. Missouri River
Energy Services

UNITED STATES
DEPARTMENT OF ENERGY
WESTERN AREA POWER ADMINISTRATION

Pick-Sloan Missouri Basin Program--Eastern Division

CONTRACT FOR MISSOURI BASIN MUNICIPAL POWER AGENCY
D.B.A. MISSOURI RIVER ENERGY SERVICES
TO ADMINISTER RENEWABLE ENERGY CERTIFICATES
FOR THE CITY OF VALLEY CITY, NORTH DAKOTA
(Designated Entity)

UNITED STATES
DEPARTMENT OF ENERGY
WESTERN AREA POWER ADMINISTRATION

Pick-Sloan Missouri Basin Program--Eastern Division

CONTRACT FOR MISSOURI BASIN MUNICIPAL POWER AGENCY
D.B.A. MISSOURI RIVER ENERGY SERVICES
TO ADMINISTER RENEWABLE ENERGY CERTIFICATES
FOR THE CITY OF VALLEY CITY, NORTH DAKOTA
(Designated Entity)

<u>Section</u>	<u>Title</u>	<u>Page</u>
1.	Preamble.....	1
2.	Explanatory Recitals.....	2
3.	Definitions	3
4.	Agreement.....	3
5.	Term.....	4
6.	Existing Firm Electric Service Contract	5
7.	Designated Entity Arrangements.....	5
8.	Billing and Payment Provisions	7
9.	General Power Contract Provisions	7
10.	No Third-Party Beneficiaries.....	8
11.	Use of Digital Signatures	8
12.	Execution in Counterparts	8
	Signatures	9

Certificate
General Power Contract Provisions dated July 17, 2025

UNITED STATES
DEPARTMENT OF ENERGY
WESTERN AREA POWER ADMINISTRATION

Pick-Sloan Missouri Basin Program--Eastern Division

CONTRACT FOR MISSOURI BASIN MUNICIPAL POWER AGENCY
D.B.A. MISSOURI RIVER ENERGY SERVICES
TO ADMINISTER RENEWABLE ENERGY CERTIFICATES
FOR THE CITY OF VALLEY CITY, NORTH DAKOTA
(Designated Entity)

1. PREAMBLE: This Contract is made on _____, pursuant to the Acts of Congress approved June 17, 1902 (32 Stat. 388), December 22, 1944 (58 Stat. 887), August 4, 1977 (91 Stat. 565), and Acts amendatory or supplementary to the foregoing Acts between the UNITED STATES OF AMERICA, acting by and through the Administrator, Western Area Power Administration, Department of Energy, hereinafter called WAPA, represented by the officer executing this Contract, a duly appointed successor, or a duly authorized representative, hereinafter called the Contracting Officer, the CITY OF VALLEY CITY, NORTH DAKOTA, a municipal corporation duly organized under and by virtue of the laws of the State of North Dakota, hereinafter called Valley City or Contractor, and MISSOURI BASIN MUNICIPAL POWER AGENCY, a body corporate and politic duly organized under and by virtue of the laws of the State of Iowa, doing business as Missouri River Energy Services, hereinafter called MRES or Contractor; their successors and assigns, each sometimes hereinafter called the Party or all sometimes hereinafter collectively called the Parties.

2. EXPLANATORY RECITALS:

2.1 WAPA's Upper Great Plains Region (WAPA-UGPR) implemented a Renewable Energy Certificate (REC) Program in 2022.

2.2 This REC Designated Entity Contract (Contract) was developed in accordance with the WAPA-UGPR REC Program Principles, effective August 7, 2025, as amended or superseded, and provides for WAPA to allocate RECs to its customers.

2.3 Valley City entered into Firm Electric Service Contract No. 14-UGPR-1004 (FES Contract), dated April 9, 2015, with WAPA for the sale of firm electric power and energy to Valley City.

2.4 RECs are considered an environmental attribute of the energy received under the FES Contract. Valley City is eligible to receive RECs in accordance with the WAPA-UGPR REC Program Principles.

2.5 Valley City selected MRES to be Valley City's Designated Entity and provide REC Management Services to Valley City.

2.6 The Parties want to terminate REC Designated Entity Contract No. 23-UGPR-154 and enter into this Contract that allows for resale of RECs.

2.7 This Contract provides the terms and conditions MRES shall follow in providing REC Management Services to Valley City, consistent with the WAPA-UGPR REC Program Principles and the applicable General Power Contract Provisions dated July 17, 2025.

3. DEFINITIONS:

3.1 Designated Entity: The entity designated by Valley City to provide REC Management Services to Valley City.

3.2 Export: The electronic movement of RECs from a Midwest Renewable Energy Tracking System (M-RETS) account to an account in another tracking system compatible with M-RETS.

3.3 Midwest Renewable Energy Tracking System (M-RETS): An online tracking system which issues, stores, retires, transfers, and exports RECs.

3.4 Renewable Energy Certificate (REC): A digital certificate which represents the generation of renewable electricity. One megawatt hour of renewable energy is equal to one REC.

3.5 REC Management Services: MRES's acceptance of the transfer or export of RECs on behalf of Valley City from WAPA and the management (e.g., retiring, transferring, exporting, or resale) of such RECs on behalf of Valley City.

3.6 Retirement: The removal of a REC from circulation for voluntary or compliance purposes. A REC cannot be transferred or sold once retired.

3.7 Transfer: The electronic movement of RECs from an M-RETS account to another M-RETS account.

4. AGREEMENT: The Parties agree to the terms and conditions set forth herein.

5. TERM:

5.1 This Contract shall become effective on its date of execution, and subject to prior termination as otherwise provided for herein, shall remain in effect until expiration or termination of the FES Contract.

5.2 Any Party may terminate this Contract, with termination effective at the end of any calendar year, upon at least 90 days' prior written notice to the other Parties. Following a material breach of this Contract by MRES and/or Valley City, any Party shall have the right to terminate this Contract, in addition to all other rights and remedies under law for damages, before the annual transfer and/or export of RECs. Such termination shall be effective immediately upon receipt of written notification to the other Parties.

5.3 WAPA may suspend or terminate the WAPA-UGPR REC Program upon 90 days' advance written notice to Valley City and MRES. If this occurs, this Contract will suspend or terminate upon the suspension or termination date of the WAPA-UGPR REC Program.

5.4 Though WAPA may solicit input, WAPA can change the WAPA-UGPR REC Program Principles, without notice, at its discretion, at which time Valley City and MRES must agree to the updated WAPA-UGPR REC Program Principles within 90 days or WAPA may terminate this Contract.

5.5 WAPA will distribute RECs in 2051 for RECs generated up to December 31, 2050, in accordance with this Contract.

5.6 TERMINATION: Contract No. 23-UGPR-154, dated November 30, 2023, between the Parties is hereby terminated as of the effective date of this Contract No. 25-UGPR-95.

6. EXISTING FIRM ELECTRIC SERVICE CONTRACT:

6.1 WAPA and Valley City entered into the FES Contract which provides for firm electric service to Valley City through December 31, 2050.

6.2 The Parties agree that by entering into this Contract, the rights, duties, and obligations contained in the FES Contract between WAPA and Valley City are unchanged.

6.3 RECs are subject to the same terms and conditions contained in Valley City's FES Contract.

7. DESIGNATED ENTITY ARRANGEMENTS: In accordance with the WAPA-UGPR REC Program:

7.1 Valley City selected MRES to be their Designated Entity, and MRES agrees to manage Valley City's RECs on Valley City's behalf.

7.2 WAPA uses M-RETS to track the RECs initially designated for Valley City.

7.3 WAPA shall transfer and/or export Valley City's RECs to MRES from M-RETS on an annual basis for MRES to manage the RECs on Valley City's behalf. WAPA shall transfer to MRES's M-RETS account unless MRES notifies WAPA of a change in MRES's tracking system account before February 1 of each year.

7.4 MRES shall provide REC Management Services to Valley City.

7.5 All transfer, export, retirement, M-RETS, and/or other tracking system account fees are the sole responsibility of MRES and/or Valley City. Valley City and/or MRES are responsible for paying applicable fees before receiving RECs from WAPA. Billing and payment for such transactions shall be in accordance with Section 8 of this Contract.

7.6 Any WAPA administrative fees associated with the transfer and/or export of RECs are the responsibility of Valley City.

7.7 WAPA will not sell or retire RECs on behalf of Valley City or MRES.

7.8 MRES may charge a fee to recover the costs of REC Management Services provided, as agreed to by Valley City and MRES.

7.9 MRES must receive electronic or written approval from Valley City before transferring, exporting, or selling Valley City's RECs to an entity not party to this Contract. MRES must provide WAPA proof of Valley City's approval upon request.

7.10 WAPA is not liable for damages related to MRES's management of Valley City's RECs. MRES and Valley City shall hold harmless and indemnify WAPA for any and all claims, liability, and damages related to the use, management, or resale of RECs.

7.11 In no event shall a Party be liable to any other Party for incidental, consequential, or indirect damages arising out of or resulting from the performance under, or brought in connection with, this Contract whether arising in contract, tort, or otherwise.

7.12 All WAPA transfers and exports of RECs are final and cannot be reversed.

7.13 Valley City and MRES are responsible for ensuring RECs transferred or exported pursuant to this Contract are not double counted, and WAPA disclaims any responsibility therefor.

7.14 WAPA makes no warranties or guarantees that the RECs associated with Federal hydropower meet any Federal, state, or local standards.

7.15 Valley City's and MRES's right to claim, hold, resell, or otherwise use RECs is only for the term of the FES Contract.

8. BILLING AND PAYMENT PROVISIONS:

8.1 Prior to the transfer and/or export of RECs, WAPA shall bill Valley City, and Valley City shall pay for any costs associated with the transfer and/or export of RECs.

8.2 WAPA will not transfer and/or export RECs until advance payment is received.

8.3 WAPA reserves the right to charge an additional administrative fee at its own discretion. WAPA shall notify Valley City before charging an administrative fee associated with the transfer and/or export of RECs.

9. GENERAL POWER CONTRACT PROVISIONS: The GPCP, effective July 17, 2025, attached hereto, are made part of this Contract the same as if they had been expressly set forth herein except that Provisions 2 through 16, 18 through 30, 33, and 36 shall not apply.

10. NO THIRD-PARTY BENEFICIARIES: There are no intended third-party beneficiaries of this Contract. Nothing in this Contract shall be construed to create any duty to, any standard of care with reference to, or any liability to, any person or entity not a Party to this Contract.

11. USE OF DIGITAL SIGNATURES: The Parties agree that this Contract may be signed and executed by digital signature in accordance with WAPA's policy. A digital signature is the same as a handwritten signature and shall be considered valid and acceptable.

12. EXECUTION IN COUNTERPARTS: This Contract may be executed in any number of counterparts and, upon execution and delivery by each Party, the executed and delivered counterparts together shall have the same force and effect as an original instrument as if all Parties had signed the same instrument. Any signature page of this Contract may be detached by any counterpart of this Contract without impairing the legal effect of any signatures thereon, and may be attached to another counterpart of this Contract identical in form hereto, by having attached to it one or more signature pages.

Contract No. 25-UGPR-95
City of Valley City, North Dakota
Missouri Basin Municipal Power
Agency d.b.a. Missouri River
Energy Services

IN WITNESS WHEREOF, the Parties have caused this Contract to be executed the day
and year first above written.

WESTERN AREA POWER ADMINISTRATION

By _____

Title Vice President of Power Marketing

for Upper Great Plains Region

Address P.O. Box 35800

Billings, MT 59107-5800

(SEAL)

CITY OF VALLEY CITY, NORTH DAKOTA

By _____

Attest:

Title _____

By _____

Address 220 3rd St. NE

Title _____

Valley City, ND 58072

(SEAL)

MISSOURI BASIN MUNICIPAL POWER AGENCY
D.B.A. MISSOURI RIVER ENERGY SERVICES

By _____

Attest:

Title VP and Chief Operating Officer

By _____

Address P.O. Box 88920

Title Senior Regulatory & Contracts Counsel

Sioux Falls, SD 57109-8920

CERTIFICATE

I, Derek J. Bertsch, certify that I am the Senior Regulatory & Contracts Counsel of Missouri Basin Municipal Power Agency d.b.a. Missouri River Energy Services, the corporation named as Contractor or MRES herein; that Terry Wolf, who signed the above Contract on behalf of MRES, was then its Vice President & Chief Operating Officer; that such Contract was duly signed for and on behalf of MRES by authority of its governing body and is within the scope of its governmental powers.

Signature

(SEAL)

WESTERN AREA POWER ADMINISTRATION
GENERAL POWER CONTRACT PROVISIONS

Page

I. APPLICABILITY.	
1. Applicability	2
II. DELIVERY OF SERVICE PROVISIONS.	
2. Character of Service.....	2
3. Use of Capacity or Energy in Excess of Contract Obligation	2
4. Continuity of Service	2
5. Multiple Points of Delivery.....	2-3
6. Metering.....	3
7. Existence of Transmission Service Contract.....	3
8. Conditions of Transmission Service	4
9. Multiple Points of Delivery Involving Direct and Indirect Deliveries.....	4
10. Construction, Operation, and Maintenance of Contractor’s Power System	4
III. RATES, BILLING, AND PAYMENT PROVISIONS.	
11. Change of Rates	5
12. Minimum Seasonal or Annual Capacity Charge.....	5
13. Billing and Payment.....	5
14. Nonpayment of Bills in Full When Due	5-6
15. Adjustments for Fractional Billing Period	6
16. Adjustments for Curtailments to Firm Service	6
IV. POWER SALES PROVISIONS.	
* 17. Resale of Firm Electric Service (Wholesale Sales for Resale).....	7
18. Distribution Principles	7
19. Contract Subject to Colorado River Compact.....	7
V. FACILITIES PROVISIONS.	
20. Design Approval	7
21. Inspection and Acceptance.....	8
22. As-Built Drawings	8
23. Equipment Ownership Markers	8
24. Third-Party Use of Facilities	8
25. Changes to Western Control Facilities.....	8
26. Modification of Western Facilities.....	9
27. Transmission Rights.....	9
28. Construction and Safety Procedures	9-10
29. Environmental Compliance.....	10
30. Responsibility for Regulated Materials.....	10
VI. OTHER PROVISIONS.	
31. Authorized Representatives of the Parties	10
32. Effect of Section Headings	10
33. Operating Guidelines and Procedures	10
34. Uncontrollable Forces	11
35. Liability.....	11
36. Cooperation of Contracting Parties.....	11
37. Transfer of Interest in the Contract or Change in Preference Status	11-12
38. Choice of Law and Forum	12
39. Waivers	12
40. Notices	12
41. Contingent Upon Appropriations and Authorization	13
42. Covenant Against Contingent Fees.....	13
43. Contract Work Hours and Safety Standards	13
* 44. Compliance with Federal Anti-Discrimination Laws	13
45. Use of Convict Labor.....	13

* Revised July 17, 2025

WESTERN AREA POWER ADMINISTRATION
GENERAL POWER CONTRACT PROVISIONS

I. APPLICABILITY.

1. Applicability.

1.1 These General Power Contract Provisions (Provisions) shall be a part of the contract to which they are attached. In the event these Provisions differ from requirements of the contract, specific terms set forth in the contract shall prevail.

1.2 If the Contractor has member utilities which are either directly or indirectly receiving benefits from the contract, then the Contractor shall require such members to comply with Provisions 10, 17, 18, 19, 29, 30, 36, 43, 44, and 45 of these General Power Contract Provisions.

II. DELIVERY OF SERVICE PROVISIONS.

2. Character of Service.

Electric energy supplied or transmitted under the contract will be three-phase, alternating current, at a nominal frequency of sixty (60) hertz (cycles per second).

3. Use of Capacity or Energy in Excess of Contract Obligation.

The Contractor is not entitled to use Federal power, energy, or capacity in amounts greater than the Western contract delivery obligation in effect for each type of service provided for in the contract except with the approval of Western. Unauthorized overruns of contract delivery obligations shall be subject to charges specified in the contract or the applicable rate schedules. Overruns shall not establish any continuing right thereto and the Contractor shall cease any overruns when requested by Western, or in the case of authorized overruns, when the approval expires, whichever occurs first. Nothing in the contract shall obligate Western to increase any delivery obligation. If additional power, energy, or capacity is not available from Western, the responsibility for securing additional power, energy, or capacity shall rest wholly with the Contractor.

4. Continuity of Service.

Electric service will be supplied or transmitted continuously except for: (1) fluctuations, interruptions, or reductions due to uncontrollable forces, as defined in Provision 34 (Uncontrollable Forces) herein, (2) fluctuations, interruptions, or reductions due to operation of devices installed for power system protection; and (3) temporary fluctuations, interruptions, or reductions, which, in the opinion of the party supplying the service, are necessary or desirable for the purposes of maintenance, repairs, replacements, installation of equipment, or investigation and inspection. The party supplying service, except in case of emergency, will give the party to whom service is being provided reasonable advance notice of such temporary interruptions or reductions and will remove the cause thereof with diligence.

5. Multiple Points of Delivery.

When electric service is supplied at or transmitted to two or more points of delivery under the same rate schedule, said rate schedule shall apply separately to the service supplied at or transmitted to each point of

delivery; Provided, That where the meter readings are considered separately, and during abnormal conditions, the Contractor's system is interconnected between points of delivery such that duplication of metered power is possible, the meter readings at each affected point of delivery will be adjusted to compensate for duplication of power demand recorded by meters at alternate points of delivery due to abnormal conditions which are beyond the Contractor's control or temporary conditions caused by scheduled outages.

6. Metering.

6.1 The total electric power and energy supplied or transmitted under the contract will be measured by metering equipment to be furnished and maintained by Western, a designated representative of Western, or where situations deem it appropriate as determined by Western, by the Contractor or its agent(s). In the event metering equipment is furnished and maintained by the Contractor or its agent(s) and the equipment is used for billing and other accounting purposes by Western, the Contractor shall ensure that the metering equipment complies with applicable metering policies established by Western.

6.2 Meters shall be secured by appropriate security measures and meters shall not be accessed except when the meters are to be inspected, tested, adjusted, or repaired. Representatives of affected parties shall be afforded reasonable opportunity to be present upon such occasions. Metering equipment shall be inspected and tested each year by the party responsible for meter maintenance, unless a different test interval is determined in accordance with good utility practices by an applicable regional metering policy, or as agreed upon by the parties. Meters shall also be tested at any reasonable time upon request by a party hereto, or by an affected supplemental power supplier, transmission agent, or control area operator. Any metering equipment found to be damaged, defective, or inaccurate shall be repaired and readjusted or replaced by the party responsible for meter maintenance as soon as practicable. Meters found with security breaches shall be tested for tampering and, if appropriate, meter readings shall be adjusted by Western pursuant to Provision 6.3 below.

6.3 Except as otherwise provided in Provision 6.4 hereof, should any meter that is used by Western for billing or other accounting purposes fail to register accurately, the electric power and energy supplied or transmitted during the period of failure to register accurately, shall, for billing purposes, be estimated by Western from the best available information.

6.4 If inspections and tests of a meter used by Western for billing or other accounting purposes disclose an error exceeding 2 percent, or a lesser range in error as agreed upon by the parties, then a correction based upon the inaccuracy found shall be made to the service records for the period of inaccuracy as determined by Western. If the period of inaccuracy cannot be determined, the inaccuracy shall be assumed to have existed during the entire monthly billing period immediately preceding the billing period in which the inspection or test was made and the resulting correction shall be made accordingly.

6.5 Any correction in billing or other accounting information that results from a correction in meter records shall be made in a subsequent monthly bill rendered by Western to the Contractor. Payment of such bill shall constitute full adjustment of any claim between the parties arising out of inaccurate metering equipment.

7. Existence of Transmission Service Contract.

If the contract provides for Western to furnish services using the facilities of a third party, the obligation of Western shall be subject to and contingent upon the existence of a transmission service contract granting Western rights to use such facilities. If Western acquires or constructs facilities which would enable it to furnish direct service to the Contractor, Western, at its option, may furnish service over its own facilities.

8. Conditions of Transmission Service.

8.1 When the electric service under the contract is furnished by Western over the facilities of others by virtue of a transmission service arrangement, the power and energy will be furnished at the voltage available and under the conditions which exist from time to time on the transmission system over which the service is supplied.

8.2 Unless otherwise provided in the contract or applicable rate schedule, the Contractor shall maintain a power factor at each point of delivery from Western's transmission agent as required by the transmission agent.

8.3 Western will endeavor to inform the Contractor from time to time of any changes planned or proposed on the system over which the service is supplied, but the costs of any changes made necessary in the Contractor's system, because of changes or conditions on the system over which the service is supplied, shall not be a charge against or a liability of Western.

8.4 If the Contractor, because of changes or conditions on the system over which service under the contract is supplied, is required to make changes on its system at its own expense in order to continue receiving service under the contract, then the Contractor may terminate service under the contract upon not less than sixty (60) days written notice given to Western prior to making such changes, but not thereafter.

8.5 If Western notifies the Contractor that electric service provided for under the contract cannot be delivered to the Contractor because of an insufficiency of capacity available to Western in the facilities of others over which service under the contract is supplied, then the Contractor may terminate service under the contract upon not less than sixty (60) days written notice given to Western prior to the date on which said capacity ceases to be available to Western, but not thereafter.

9. Multiple Points of Delivery Involving Direct and Indirect Deliveries.

When Western has provided line and substation capacity under the contract for the purpose of delivering electric service directly to the Contractor at specified direct points of delivery and also has agreed to absorb transmission service allowance or discounts for deliveries of energy over other system(s) to indirect points of delivery and the Contractor shifts any of its load served under the contract from direct delivery to indirect delivery, Western will not absorb the transmission service costs on such shifted load until the unused capacity, as determined solely by Western, available at the direct delivery points affected is fully utilized.

10. Construction, Operation, and Maintenance of Contractor's Power System.

The Contractor shall, and, if applicable, shall require each of its members or transmission agents to construct, operate, and maintain its power system in a manner which, as determined by Western, will not interfere with the operation of the system of Western or its transmission agents over which electric services are furnished to the Contractor under the contract, and in a manner which will coordinate with the protective relaying and other protective arrangements of the system(s) of Western or Western's transmission agents. Western may reduce or discontinue furnishing services to the Contractor if, after notice by Western, the Contractor fails or refuses to make such changes as may be necessary to eliminate an unsatisfactory condition on the Contractor's power system which is determined by Western to interfere significantly under current or probable conditions with any service supplied from the power system of Western or from the power system of a transmission agent of Western. Such a reduction or discontinuance of service will not relieve the Contractor of liability for any minimum charges provided for in the contract during the time said services are reduced or discontinued. Nothing in this Provision shall be construed to render Western liable in any manner for any claims, demands, costs, losses, causes of action, damages, or liability of any kind or nature arising out of or resulting from the construction, operation, or maintenance of the Contractor's power system.

III. RATES, BILLING, AND PAYMENT PROVISIONS.

11. Change of Rates.

Rates applicable under the contract shall be subject to change by Western in accordance with appropriate rate adjustment procedures. If at any time the United States promulgates a rate changing a rate then in effect under the contract, it will promptly notify the Contractor thereof. Rates shall become effective as to the contract as of the effective date of such rate. The Contractor, by written notice to Western within ninety (90) days after the effective date of a rate change, may elect to terminate the service billed by Western under the new rate. Said termination shall be effective on the last day of the billing period requested by the Contractor not later than two (2) years after the effective date of the new rate. Service provided by Western shall be paid for at the new rate regardless of whether the Contractor exercises the option to terminate service.

12. Minimum Seasonal or Annual Capacity Charge.

When the rate in effect under the contract provides for a minimum seasonal or annual capacity charge, a statement of the minimum capacity charge due, if any, shall be included in the bill rendered for service for the last billing period of the service season or contract year as appropriate, adjusted for increases or decreases in the contract rate of delivery and for the number of billing periods during the year or season in which service is not provided. Where multiple points of delivery are involved and the contract rate of delivery is stated to be a maximum aggregate rate of delivery for all points, in determining the minimum seasonal or annual capacity charge due, if any, the monthly capacity charges at the individual points of delivery shall be added together.

13. Billing and Payment.

13.1 Western will normally issue bills to the Contractor for services furnished during the preceding month within ten (10) days after the end of the billing period.

13.2 If Western is unable to issue timely monthly bill(s), Western may elect to render estimated bill(s). Such estimated bill(s) shall be subject to the same payment provisions as final bill(s), and any applicable adjustments will be shown on a subsequent monthly bill.

13.3 Payments of bills issued by Western are due and payable by the Contractor before the close of business on the twentieth (20th) calendar day after the date of issuance of each bill or the next business day thereafter if said day is a Saturday, Sunday, or Federal holiday. Bills shall be considered paid when payment is received by Western. Bills will be paid electronically or via the Automated Clearing House method of payment unless a written request to make payments by mail is submitted by the Contractor and approved by Western. Should Western agree to accept payments by mail, these payments will be accepted as timely and without assessment of the charge provided for in Provision 14 (Nonpayment of Bills in Full When Due) if a United States Post Office first class mail postmark indicates the payment was mailed at least three (3) calendar days before the due date.

13.4 The parties agree that net billing procedures will be used for payments due Western by the Contractor and for payments due the Contractor by Western for the sale or exchange of electric power and energy, use of transmission facilities, operation and maintenance of electric facilities, and other services. Payments due one party in any month shall be offset against payments due the other party in such month, and the resulting net balance shall be paid to the party in whose favor such balance exists. The parties shall exchange such reports and information that either party requires for billing purposes. Net billing shall not be used for any amounts due which are in dispute.

14. Nonpayment of Bills in Full When Due.

14.1 Bills not paid in full by the Contractor by the due date specified in Provision 13 (Billing and

Payment) hereof shall bear a charge of five hundredths percent (0.05%) of the principal sum unpaid for each day payment is delinquent, to be added until the amount due is paid in full. Western will also assess a fee of twenty-five dollars (\$25.00) for processing a late payment. Payments received will first be applied to the charges for late payment assessed on the principal and then to payment of the principal.

14.2 Western shall have the right, upon not less than fifteen (15) days advance written notice, to discontinue furnishing the services specified in the contract for nonpayment of bills in full when due, and to refuse to resume such services so long as any part of the amount due remains unpaid. Such a discontinuance of service will not relieve the Contractor of liability for minimum charges during the time service is so discontinued. The rights reserved to Western herein shall be in addition to all other remedies available to Western either by law or in equity, for the breach of any of the terms hereof.

15. Adjustments for Fractional Billing Period.

The demand or capacity charge and minimum charges shall each be proportionately adjusted when fractional billing periods are applicable under this contract. A fractional billing period can occur: 1) at the beginning or end of electric service; 2) at the beginning or end of irrigation pumping service each year; 3) for a fractional billing period under a new rate schedule; or 4) for fractional periods due to withdrawals of electric services. The adjustment will be made based on the ratio of the number of hours that electric service is available to the Contractor in such fractional billing period, to the total number of hours in the billing period involved. Energy billing shall not be affected by fractional billing periods.

16. Adjustments for Curtailments to Firm Service.

16.1 Billing adjustments will be made if firm electric service is interrupted or reduced because of conditions on the power system of the United States for periods of one (1) hour or longer in duration each. Billing adjustments will not be made when such curtailment of electric service is due to a request by the Contractor or a discontinuance of electric service by Western pursuant to Provision 14 (Nonpayment of Bills In Full When Due). For purposes of billing adjustments under this Provision, the term power system of the United States shall include transmission facilities used under contract but not owned by the United States.

16.2 The total number of hours of curtailed firm electric service in any billing period shall be determined by adding: (1) the sum of the number of hours of interrupted electric service to (2) the product, of each reduction, of: the number of hours reduced electric service and the percentage by which electric service was reduced below the delivery obligation of Western at the time of each said reduction of electric service. The demand or capacity charge and applicable minimum charges shall each be proportionately adjusted in the ratio that the total number of hours of electric service determined to have been curtailed bears to the total number of hours in the billing period involved.

16.3 The Contractor shall make written claim within thirty (30) days after receiving the monthly bill, for adjustment on account of any curtailment of firm electric service, for periods of one (1) hour or longer in duration each, alleged to have occurred that is not reflected in said bill. Failure to make such written claim, within said thirty-day (30-day) period, shall constitute a waiver of said claim. All curtailments of electric service, which are due to conditions on the power system of the United States, shall be subject to the terms of this Provision; Provided, That withdrawal of power and energy under the contract shall not be considered a curtailment of electric service.

IV. POWER SALES PROVISIONS.

17. Resale of Firm Electric Service (Wholesale Sales for Resale).

17.1 The Contractor shall not sell any firm electric power or energy supplied under the contract to any electric utility customer of the Contractor for resale by that utility customer; Provided, That the Contractor may sell the electric power and energy supplied under the contract to its members on condition that said members not sell any of said power and energy to any customer of the member for resale by that customer.

17.2 Contractors receiving environmental attributes associated with any firm electric power or energy allocated under the contract may use, dispose of, transfer, or resell such environmental attributes in accordance with good utility practice.

18. Distribution Principles.

The Contractor agrees that the benefits of firm electric power or energy supplied under the contract shall be made available to its consumers at rates that are established at the lowest possible level consistent with sound business principles, and that these rates will be established in an open and public manner. The Contractor further agrees that it will identify the costs of firm electric power or energy supplied under the contract and power from other sources to its consumers upon request. The Contractor will demonstrate compliance with the requirements of this Provision to Western upon request.

19. Contract Subject to Colorado River Compact.

Where the energy sold under the contract is generated from waters of the Colorado River system, the contract is made upon the express condition and with the express covenant that all rights under the contract shall be subject to and controlled by the Colorado River Compact approved by Section 13 (a) of the Boulder Canyon Project Act of December 21, 1928, 43 U.S.C. §§ 617a-e, and the parties to the contract shall observe and be subject to and controlled by said Colorado River Compact in the construction, management, and operation of the dams, reservoirs, and powerplants from which electrical energy is to be furnished by Western to the Contractor under the contract, and in the storage, diversion, delivery, and use of water for the generation of electrical energy to be delivered by Western to the Contractor under the contract.

V. FACILITIES PROVISIONS.

20. Design Approval.

All facilities, construction, and installation by the Contractor pursuant to the contract shall be subject to the approval of Western. Facilities interconnections shall normally conform to Western's current "General Requirements for Interconnection," in effect upon the signing of the contract document providing for each interconnection, copies of which are available from Western. At least ninety (90) days, unless otherwise agreed, prior to the date the Contractor proposes to commence construction or to incur an obligation to purchase facilities to be installed pursuant to the contract, whichever date is the earlier, the Contractor shall submit, for the approval of Western, detailed designs, drawings, and specifications of the facilities the Contractor proposes to purchase, construct, and install. The Contractor assumes all risks for construction commenced or obligations to purchase facilities incurred prior to receipt of approval from Western. Western review and approval of designs and construction work in no way implies that Western is certifying that the designs meet the Contractor's needs.

21. Inspection and Acceptance.

Western shall have the right to inspect the materials and work furnished by the Contractor, its agents, employees, and subcontractors pursuant to the contract. Such inspections shall be at reasonable times at the work site. Any materials or work that Western determines is defective or not in accordance with designs, drawings, and specifications, as approved by Western, shall be replaced or modified, as directed by Western, at the sole expense of the Contractor before the new facilities are energized.

22. As-Built Drawings.

Within a reasonable time, as determined by Western, after the completion of construction and installation of facilities pursuant to the contract, the Contractor shall submit to Western marked as-built prints of all Western drawings affected by changes made pursuant to the contract and reproducible drawings the Contractor has prepared showing facilities of Western. The Contractor's drawings of Western facilities shall use drawing title blocks, drawing numbers, and shall be prepared in accordance with drafting standards all as approved by Western. Western may prepare, revise, or complete said drawings and bill the Contractor if the Contractor fails to provide such drawings to Western within a reasonable time as determined by Western.

23. Equipment Ownership Markers.

23.1 The Contractor shall identify all movable equipment and, to the extent agreed upon by the parties, all other salvageable facilities constructed or installed on the United States right-of-way or in Western substations pursuant to the contract which are owned by the Contractor, by permanently affixing thereto suitable markers clearly identifying the Contractor as the owner of said equipment and facilities.

23.2 If requested by the Contractor, Western shall identify all movable equipment and, to the extent agreed upon by the parties, all other salvageable facilities constructed or installed on the Contractor's right-of-way or in the Contractor's substations pursuant to the contract which are owned by the United States, by permanently affixing thereto suitable markers clearly identifying the United States as the owner of said equipment and facilities.

24. Third-Party Use of Facilities.

The Contractor shall notify Western of any proposed system change relating to the facilities governed by the contract or allowing third-party use of the facilities governed by the contract. If Western notifies the Contractor that said system change will, as solely determined by Western, adversely affect the operation of Western's system the Contractor shall, at no cost to Western, provide a solution to said adverse effect acceptable to Western.

25. Changes to Western Control Facilities.

If at any time during the term of the contract, Western determines that changes or additions to control, relay, or communications facilities are necessary to maintain the reliability or control of Western's transmission system, and said changes or additions are entirely or partially required because of the Contractor's equipment installed under the contract, such changes or additions shall, after consultation with the Contractor, be made by Western with all costs or a proportionate share of all costs, as determined by Western, to be paid by the Contractor. Western shall notify the Contractor in writing of the necessary changes or additions and the estimated costs to be paid by the Contractor. If the Contractor fails to pay its share of said estimated costs, Western shall have the right, after giving sixty (60) days' written notice to the Contractor, to terminate the applicable facility installation provisions to the contract and require the removal of the Contractor's facilities.

26. Modification of Western Facilities.

Western reserves the right, at any time, to modify its facilities. Western shall keep the Contractor informed of all planned modifications to Western facilities which impact the facilities installation pursuant to the contract. Western shall permit the Contractor to change or modify its facilities, in a manner satisfactory to and at no cost or expense to Western, to retain the facilities interconnection pursuant to the contract. At the Contractor's option, Western shall cooperate with the Contractor in planning alternate arrangements for service which shall be implemented at no cost or expense to Western. The Contractor and Western shall modify the contract, as necessary, to conform to the new facilities arrangements.

27. Transmission Rights.

If the contract involves an installation which sectionalizes a Western transmission line, the Contractor hereby agrees to provide a transmission path to Western across such sectionalizing facilities at no cost or expense to Western. Said transmission path shall be at least equal, in terms of capacity and reliability, to the path in the Western transmission line prior to the installation pursuant to the contract.

28. Construction and Safety Procedures.

28.1 The Contractor hereby acknowledges that it is aware of the hazards inherent in high-voltage electric lines and substations, and hereby assumes full responsibility at all times for the adoption and use of necessary safety measures required to prevent accidental harm to personnel engaged in the construction, inspection, testing, operation, maintenance, replacement, or removal activities of the Contractor pursuant to the contract. The Contractor and the authorized employees, agents, and subcontractors of the Contractor shall comply with all applicable safety laws and building and construction codes, including the provisions of Chapter 1 of the Power System Operations Manual, entitled Power System Switching Procedure, and the Occupational Safety and Health Administration regulations, Title 29 C.F.R. §§ 1910 and 1926, as amended or supplemented. In addition to the safety program required herein, upon request of the United States, the Contractor shall provide sufficient information to demonstrate that the Contractor's safety program is satisfactory to the United States.

28.2 The Contractor and its authorized employees, agents, and subcontractors shall familiarize themselves with the location and character of all the transmission facilities of Western and interconnections of others relating to the work performed by the Contractor under the contract. Prior to starting any construction, installation, or removal work, the Contractor shall submit a plan of procedure to Western which shall indicate the sequence and method of performing the work in a safe manner. No work shall be performed by the Contractor, its employees, agents, or subcontractors until written authorization to proceed is obtained from Western.

28.3 At all times when the Contractor, its employees, agents, or subcontractors are performing activities of any type pursuant to the contract, such activities shall be under supervision of a qualified employee, agent, or subcontractor of the Contractor who shall be authorized to represent the Contractor in all matters pertaining to the activity being performed. The Contractor and Western will keep each other informed of the names of their designated representatives at the site.

28.4 Upon completion of its work, the Contractor shall remove from the vicinity of the right-of-way of the United States all buildings, rubbish, used materials, concrete forms, and other like material belonging to the Contractor or used under the Contractor's direction, and in the event of failure to do so the same may be removed by Western at the expense of the Contractor.

28.5 In the event the Contractor, its employees, agents, or subcontractors fail to comply with any requirement of this Provision, or Provision 21 (Inspection and Acceptance) herein, Western or an authorized representative may issue an order to stop all or any part of the work until such time as the Contractor demonstrates

compliance with the provision at issue. The Contractor, its employees, agents, or subcontractors shall make no claim for compensation or damages resulting from such work stoppage.

29. Environmental Compliance.

Facilities installed under the contract by any party shall be constructed, operated, maintained, replaced, transported, and removed subject to compliance with all applicable laws, including but not limited to the National Historic Preservation Act of 1966, 16 U.S.C. §§ 470x-6, the National Environmental Policy Act of 1969, 42 U.S.C. §§ 4321-4347, the Endangered Species Act of 1973, 16 U.S.C. §§ 1531-1544, and the Archaeological Resources Protection Act of 1979, 16 U.S.C. §§ 470aa-470mm, and the regulations and executive orders implementing these laws, as they may be amended or supplemented, as well as any other existing or subsequent applicable laws, regulations, and executive orders.

30. Responsibility for Regulated Materials.

When either party owns equipment containing regulated material located on the other party's substation, switchyard, right-of-way, or other property, the equipment owner shall be responsible for all activities related to regulated materials in such equipment that are necessary to meet the requirements of the Toxic Substances Control Act, 15 U.S.C. §§ 2601-2692, the Resource Conservation and Recovery Act, 42 U.S.C. §§ 6901-6992k, the Comprehensive Environmental Response, Compensation, and Liability Act of 1980, 42 U.S.C. §§ 9601-9675, the Oil Pollution Act of 1990, 33 U.S.C. §§ 2702-2761, the Clean Water Act, 33 U.S.C. §§ 1251-1387, the Safe Drinking Water Act, 42 U.S.C. §§ 300f-j26, and the regulations and executive orders implementing these laws, as they may be amended or supplemented, and any other existing or subsequent applicable laws, regulations, and executive orders. Each party shall label its equipment containing regulated material in accordance with appropriate laws and regulations. If the party owning the equipment does not perform activities required under appropriate laws and regulations within the time frame specified therein, the other party may perform or cause to be performed the required activities after notice to and at the sole expense of the party owning the equipment.

VI. OTHER PROVISIONS.

31. Authorized Representatives of the Parties.

Each party to the contract, by written notice to the other, shall designate the representative(s) who is (are) authorized to act in its behalf with respect to those matters contained in the contract which are the functions and responsibilities of the authorized representatives of the parties. Each party may change the designation of its authorized representative(s) upon oral notice given to the other, confirmed promptly by written notice.

32. Effect of Section Headings.

Section headings or Provision titles appearing in the contract or these General Power Contract Provisions are inserted for convenience only and shall not be construed as interpretations of text.

33. Operating Guidelines and Procedures.

The parties to the contract may agree upon and put into effect from time to time, such other written guidelines and procedures as may be required in order to establish the methods of operation of the power system to be followed in the performance of the contract.

34. Uncontrollable Forces.

Neither party to the contract shall be considered to be in default in performance of any of its obligations under the contract, except to make payment as specified in Provision 13 (Billing and Payment) herein, when a failure of performance shall be due to an uncontrollable force. The term “uncontrollable force” means any cause beyond the control of the party affected, including but not restricted to, failure of or threat of failure of facilities, flood, earthquake, storm, fire, lightning, epidemic, war, riot, civil disturbance or disobedience, labor dispute, labor or material shortage, sabotage, restraint by court order or public authority and action or nonaction by, or failure to obtain the necessary authorizations or approvals from, any governmental agency or authority, which by exercise of due diligence such party could not reasonably have been expected to avoid and which by exercise of due diligence it shall be unable to overcome. Nothing contained herein shall be construed to require a party to settle any strike or labor dispute in which it may be involved. Either party rendered unable to fulfill any of its obligations under the contract by reason of an uncontrollable force shall give prompt written notice of such fact to the other party and shall exercise due diligence to remove such inability with all reasonable dispatch.

35. Liability.

35.1 The Contractor hereby agrees to indemnify and hold harmless the United States, its employees, agents, or contractors from any loss or damage and from any liability on account of personal injury, death, or property damage, or claims for personal injury, death, or property damage of any nature whatsoever and by whomsoever made arising out of the Contractors’, its employees’, agents’, or subcontractors’ construction, operation, maintenance, or replacement activities under the contract.

35.2 The United States is liable only for negligence on the part of its officers and employees in accordance with the Federal Tort Claims Act, 28 U.S.C. §§ 1346(b), 1346(c), 2401(b), 2402, 2671, 2672, 2674-2680, as amended or supplemented.

36. Cooperation of Contracting Parties.

If, in the operation and maintenance of their respective power systems or electrical equipment and the utilization thereof for the purposes of the contract, it becomes necessary by reason of any emergency or extraordinary condition for either party to request the other to furnish personnel, materials, tools, and equipment for the accomplishment thereof, the party so requested shall cooperate with the other and render such assistance as the party so requested may determine to be available. The party making such request, upon receipt of properly itemized bills from the other party, shall reimburse the party rendering such assistance for all costs properly and reasonably incurred by it in such performance, including administrative and general expenses, such costs to be determined on the basis of current charges or rates used in its own operations by the party rendering assistance. Issuance and payment of bills for services provided by Western shall be in accordance with Provisions 13 (Billing and Payment) and 14 (Nonpayment of Bills in Full When Due) herein. Western shall pay bills issued by the Contractor for services provided as soon as the necessary vouchers can be prepared which shall normally be within twenty (20) days.

37. Transfer of Interest in Contract or Change in Preference Status.

37.1 No voluntary transfer of the contract or of the rights of the Contractor under the contract shall be made without the prior written approval of the Administrator of Western. Any voluntary transfer of the contract or of the rights of the Contractor under the contract made without the prior written approval of the Administrator of Western may result in the termination of the contract; Provided, That the written approval of the Administrator shall not be unreasonably withheld; Provided further, That if the Contractor operates a project financed in whole or in part by the Rural Utilities Service, the Contractor may transfer or assign its interest in the contract to the Rural Utilities Service or any other department or agency of the Federal Government without such prior written approval; Provided further, That any successor to or assignee of the rights of the Contractor, whether by voluntary transfer, judicial sale,

foreclosure sale, or otherwise, shall be subject to all the provisions and conditions of the contract to the same extent as though such successor or assignee were the original Contractor under the contract; and, Provided further, That the execution of a mortgage or trust deed, or judicial or foreclosure sales made thereunder, shall not be deemed voluntary transfers within the meaning of this Provision.

37.2 The Contractor shall maintain its status as an entity eligible for preference in Western's sale of Federal power pursuant to Reclamation law, as amended and supplemented.

37.3 Western shall give the Contractor written notice of Western's proposed determination that the Contractor has violated Provision 37.1 and Western's proposed action in response to the violation.

37.4 The Contractor shall have 120 days after receipt of Western's notice provided under Provision 37.3 to submit a written response to Western. The Contractor may also make an oral presentation to the Administrator during this 120-day period.

37.5 At any time during this process, the Contractor and Western may agree upon corrective action to resolve Western's proposed determination that the Contractor is in violation of Provision 37.1.

37.6 Within 30 days of receipt of the Contractor's written response provided under Provision 37.4, Western will notify the Contractor in writing of its final decision. The Administrator's written notice will include the intended action, the effective date thereof, and the reasons for taking the intended action. Implementation of the Administrator's action shall take place no earlier than 60 days from the Contractor's receipt of such notice.

37.7 Any successor to Western shall be subject to all the provisions and conditions of the contract to the same extent as though such successor were an original signatory to the contract.

37.8 Nothing in this Provision shall preclude any right to judicial review available to the Contractor under Federal law.

38. Choice of Law and Forum.

Federal law shall control the obligations and procedures established by this contract and the performance and enforcement thereof. The forum for litigation arising from this contract shall exclusively be a Federal court of the United States, unless the parties agree to pursue alternative dispute resolution.

39. Waivers.

Any waivers at any time by either party to the contract of its rights with respect to a default or any other matter arising under or in connection with the contract shall not be deemed a waiver with respect to any subsequent default or matter.

40. Notices.

Any notice, demand, or request specifically required by the contract or these Provisions to be in writing shall be considered properly given when delivered in person or sent by postage prepaid registered or certified mail, commercial delivery service, facsimile, electronic, prepaid telegram, or by other means with prior agreement of the parties, to each party's authorized representative at the principal offices of the party. The designation of the person to be notified may be changed at any time by similar notice. Where facsimile or electronic means are utilized for any communication covered by this Provision, the sending party shall keep a contemporaneous record of such communications and shall verify receipt by the other party.

41. Contingent Upon Appropriations and Authorization.

41.1 Where activities provided for in the contract extend beyond the current fiscal year, continued expenditures by the United States are contingent upon Congress making the necessary appropriations required for the continued performance of the United States' obligations under the contract. In case such appropriation is not made, the Contractor hereby releases the United States from its contractual obligations and from all liability due to the failure of Congress to make such appropriation.

41.2 In order to receive and expend funds advanced from the Contractor necessary for the continued performance of the obligations of the United States under the contract, additional authorization may be required. In case such authorization is not received, the Contractor hereby releases the United States from those contractual obligations and from all liability due to the lack of such authorization.

42. Covenant Against Contingent Fees.

The Contractor warrants that no person or selling agency has been employed or retained to solicit or secure the contract upon an agreement or understanding for a commission, percentage, brokerage, or contingent fee, excepting bona fide employees or bona fide established commercial or selling agencies maintained by the Contractor for the purpose of securing business. For breach or violation of this warranty, Western shall have the right to annul the contract without liability or in its discretion to deduct from the contract price or consideration the full amount of such commission, percentage, brokerage, or contingent fee.

43. Contract Work Hours and Safety Standards.

The contract, to the extent that it is of a character specified in Section 103 of the Contract Work Hours and Safety Standards Act (Act), 40 U.S.C. § 3701, as amended or supplemented, is subject to the provisions of the Act, 40 U.S.C. §§ 3701-3708, as amended or supplemented, and to regulations promulgated by the Secretary of Labor pursuant to the Act.

44. Compliance with Federal Anti-Discrimination Laws.

44.1 The Contractor shall comply with all applicable Federal anti-discrimination laws. Compliance with applicable Federal anti-discrimination laws is material to eligibility for and payment under this contract for purposes of 31 U.S.C. 3729(b)(4).

44.2 By executing this agreement, the Contractor certifies that, to the best of its knowledge and belief, it does not operate programs promoting diversity, equity, and inclusion that violate any applicable Federal anti-discrimination laws. "Program promoting diversity, equity, and inclusion" means a program whose purpose is to promote preferences based on race, color, religion, sex, or national origins, such as in training or hiring.

44.3 Indian Tribes and tribal organizations may apply Indian preference to the extent permitted by Federal law.

45. Use of Convict Labor.

The Contractor agrees not to employ any person undergoing sentence of imprisonment in performing the contract except as provided by 18 U.S.C. § 3622(c), as amended or supplemented, and Executive Order No. 11755, 39 Fed. Reg. 779 (1973), as amended or supplemented.

Contract No. [2325-UGPR-15495](#)
City of Valley City, North Dakota
Missouri Basin Municipal Power
Agency d.b.a. Missouri River
Energy Services

UNITED STATES
DEPARTMENT OF ENERGY
WESTERN AREA POWER ADMINISTRATION

Pick-Sloan Missouri Basin Program--Eastern Division

CONTRACT FOR MISSOURI BASIN MUNICIPAL POWER AGENCY ~~D.B.A.~~
~~MISSOURI RIVER ENERGY SERVICES~~ [TO ADMINISTER](#)
[D.B.A. MISSOURI RIVER ENERGY SERVICES](#)
[TO ADMINISTER](#) RENEWABLE ENERGY CERTIFICATES
FOR THE CITY OF VALLEY CITY, NORTH DAKOTA
(Designated Entity)

UNITED STATES
DEPARTMENT OF ENERGY
WESTERN AREA POWER ADMINISTRATION

Pick-Sloan Missouri Basin Program--Eastern Division

CONTRACT FOR MISSOURI BASIN MUNICIPAL POWER AGENCY ~~D.B.A. MISSOURI~~
~~RIVER ENERGY SERVICES TO ADMINISTER~~
~~D.B.A. MISSOURI RIVER ENERGY SERVICES~~
TO ADMINISTER RENEWABLE ENERGY CERTIFICATES
FOR THE CITY OF VALLEY CITY, NORTH DAKOTA
(Designated Entity)

<u>Section</u>	<u>Title</u>	<u>Page</u>
1.	Preamble.....	1
2.	Explanatory Recitals.....	2
3.	Definitions.....	23
4.	Agreement.....	3
5.	Term.....	4
6.	Existing Firm Electric Service Contract.....	45
7.	Designated Entity Arrangements.....	5
8.	Billing and Payment Provisions.....	67
9.	General Power Contract Provisions.....	7
10.	No Third-Party Beneficiaries.....	78
11.	Use of Digital Signatures.....	78
12.	Execution in Counterparts.....	78
	Signatures.....	9

Certificate
General Power Contract Provisions dated ~~September 1, 2007~~ [July 17, 2025](#)

Contract No. [2325-UGPR-15495](#)
City of Valley City, North Dakota
Missouri Basin Municipal Power
Agency d.b.a. Missouri River
Energy Services

UNITED STATES
DEPARTMENT OF ENERGY
WESTERN AREA POWER ADMINISTRATION

Pick-Sloan Missouri Basin Program--Eastern Division

CONTRACT FOR MISSOURI BASIN MUNICIPAL POWER AGENCY ~~D.B.A. MISSOURI~~
~~RIVER ENERGY SERVICES TO ADMINISTER~~
~~D.B.A. MISSOURI RIVER ENERGY SERVICES~~
TO ADMINISTER RENEWABLE ENERGY CERTIFICATES
FOR THE CITY OF VALLEY CITY, NORTH DAKOTA
(Designated Entity)

1. PREAMBLE: This Contract is made on _____
_____, pursuant to the Acts of Congress approved June 17,
1902 (32 Stat. 388), December 22, 1944 (58 Stat. 887), August 4, 1977 (91 Stat. 565),
and Acts amendatory or supplementary to the foregoing Acts between the UNITED
STATES OF AMERICA, acting by and through the Administrator, Western Area Power
Administration, Department of Energy, hereinafter called WAPA, represented by the
officer executing this Contract, a duly appointed successor, or a duly authorized
representative, hereinafter called the Contracting Officer, the CITY OF VALLEY CITY,
NORTH DAKOTA, a municipal corporation duly organized under and by virtue of the
laws of the State of North Dakota, hereinafter called Valley City or Contractor, ~~their~~
~~successor and assigns,~~ and MISSOURI BASIN MUNICIPAL POWER AGENCY, a body
corporate and politic duly organized under and by virtue of the laws of the State of Iowa,
doing business as Missouri River Energy Services, hereinafter called MRES or

Contractor, their successors ~~or~~ and assigns, each sometimes hereinafter called the Party or all sometimes hereinafter collectively called the Parties.

2. EXPLANATORY RECITALS:

2.1 WAPA's Upper Great Plains Region (WAPA-UGPR) implemented a ~~new~~ Renewable Energy Certificate (REC) Program in 2022.

2.2 This REC Designated Entity Contract (Contract) was developed in accordance with the WAPA-UGPR REC Program Principles, effective ~~September 27, 2022, as amended~~ August 7, 2025, as amended or superseded, and provides for WAPA to allocate RECs to its customers.

2.3 Valley City entered into Firm Electric Service Contract No. 14-UGPR-1004 (FES Contract), dated April 9, 2015, with WAPA for the sale of firm electric power and energy to Valley City.

2.4 RECs are considered an environmental attribute of the energy received under the FES Contract. Valley City is eligible to receive RECs in accordance with the WAPA-UGPR REC Program Principles.

2.5 Valley City selected MRES to be Valley City's Designated Entity and provide REC Management Services ~~for~~to Valley City.

~~2.6~~ 2.6 The Parties want to terminate REC Designated Entity Contract No. 23-UGPR-154 and enter into this Contract that allows for resale of RECs.

2.7 This Contract provides the terms and conditions MRES shall follow in providing REC Management Services to Valley City, consistent with the WAPA-UGPR REC

Program Principles and the applicable General Power Contract Provisions dated
[September 1, 2007. July 17, 2025.](#)

3. DEFINITIONS:

3.1 Designated Entity: The entity designated by Valley City to provide REC Management Services ~~for~~[to](#) Valley City.

3.2 Export: The electronic movement of RECs from a Midwest Renewable Energy Tracking System (M-RETS) account to an account in another tracking system compatible with M-RETS.

3.3 Midwest Renewable Energy Tracking System (M-RETS): An online tracking system which issues, stores, retires, transfers, and exports RECs.

3.4 Renewable Energy Certificate (REC): A digital certificate which represents the generation of renewable electricity. One megawatt hour of renewable energy is equal to one REC.

3.5 REC Management Services: ~~The~~[MRES's](#) acceptance of the transfer [or export](#) of RECs on behalf of Valley City from WAPA and the ~~retirement~~[management \(e.g., retiring, transferring, exporting, or resale\)](#) of such RECs on behalf of Valley City.

3.6 Retirement: The removal of a REC from circulation for voluntary or compliance purposes. A REC cannot be transferred or sold once retired.

3.7 Transfer: The electronic movement of RECs from an M-RETS account to another M-RETS account.

~~3.8 WAPA UGPR Marketing Area: Montana (east of the Continental Divide), all of North Dakota and South Dakota, Nebraska east of the 101° meridian, Iowa west of the 94½° meridian, and Minnesota west of a line on the 94½° meridian from the southern boundary of the state to the 46° parallel and then northwesterly to the northern boundary of the state at the 96½° meridian.~~

4. AGREEMENT: The Parties agree to the terms and conditions set forth herein.

5. TERM:

5.1 This Contract shall become effective on its date of execution, and subject to prior termination as otherwise provided for herein, shall remain in effect until expiration or termination of the FES Contract.

5.2 Any Party may terminate this Contract, with termination effective at the end of any calendar year, upon at least 90 days' prior written notice to the other Parties. Following a material breach of this Contract by MRES and/or Valley City, any Party shall have the right to terminate this Contract, in addition to all other rights and remedies under law for damages, before the annual transfer [and/or export](#) of RECs. Such termination shall be effective immediately upon receipt of written notification to the other Parties.

5.3 WAPA may suspend or terminate the [WAPA-UGPR](#) REC Program upon 90 days' advance written notice to [UGPR customers Valley City and MRES](#). If this occurs, this

Contract will suspend or terminate upon the suspension or termination date of the [WAPA-UGPR REC Program](#).

[5.4 Though WAPA may solicit input, WAPA can change the WAPA-UGPR REC Program Principles, without notice, at its discretion, at which time Valley City and MRES must agree to the updated WAPA-UGPR REC Program Principles within 90 days or WAPA may terminate this Contract.](#)

[5.5 WAPA will distribute RECs in 2051 for RECs generated up to December 31, 2050, in accordance with this Contract.](#)

[5.6 TERMINATION: Contract No. 23-UGPR-154, dated November 30, 2023, between the Parties is hereby terminated as of the effective date of this Contract No. 25-UGPR-95.](#)

6. EXISTING FIRM ELECTRIC SERVICE CONTRACT:

6.1 WAPA and Valley City entered into the FES Contract which provides for firm electric service to Valley City through December 31, 2050.

6.2 The Parties agree that by entering into this Contract, the rights, duties, and obligations contained in the FES Contract between WAPA and Valley [CityareCity are](#) unchanged.

6.3 RECs are subject to the same terms and conditions contained in Valley City's FES Contract.

7. DESIGNATED ENTITY ARRANGEMENTS: In accordance with the WAPA-
UGPR'sUGPR REC Program:

7.1 Valley City selected MRES to be their Designated Entity, and MRES agrees to manage Valley City's RECs on Valley City's behalf.

7.2 WAPA uses M-RETS to track the RECs initially designated for Valley City.

7.3 WAPA shall transfer and/or export Valley City's RECs to MRES from M-RETS on an annual basis for MRES to manage the RECs on Valley City's behalf. WAPA shall transfer to MRES's M-RETS account unless MRES notifies WAPA of a change in MRES's tracking system account before February 1 of each year.

7.34 MRES shall provide REC Management Services to Valley City.

7.45 All transfer, export, retirement, and M-RETS, and/or other tracking system account fees are the sole responsibility of MRES and/or Valley City. As of the execution date Valley City and/or MRES are responsible for paying applicable fees before receiving RECs from WAPA. Billing and payment for such transactions shall be in accordance with Section 8 of this Contract, there are no fees for transfers between M-RETS accounts. This is subject to change should M-RETS begin charging for transfers.

7.5-7.6 Any WAPA administrative fees associated with the transfer and/or export of RECs are the responsibility of Valley City.

7.7 WAPA will not sell or retire RECs on behalf of Valley City or MRES.

7.6 Upon WAPA's receipt of any required payment, WAPA will transfer or export RECs to MRES.

~~7.7 RECs issued to Valley City cannot be resold. This includes RECs transferred or exported to MRES on behalf of Valley City.~~

7.8 MRES may charge a fee to recover the costs of REC Management Services provided, as agreed to by Valley City and MRES.

~~7.9 If MRES transfers must receive electronic or exports RECs to another entity, MRES must ensure the transferred and/or exported RECs are not sold. MRES may charge a fee to recover the costs of written approval from Valley City before transferring and/or, exporting RECs to, or selling Valley City's members and/or end use customers. RECs to an entity not party to this Contract. MRES must provide WAPA proof of Valley City's members or end use customers must be located within the WAPA-UGPR Marketing Area approval upon request.~~

7.10 WAPA is not liable for damages related to ~~MRES'~~MRES's management of Valley City's RECs. MRES and Valley City shall hold harmless and indemnify WAPA for any and all claims, liability, and damages related to the use, management, or resale of RECs.

7.11 In no event shall a Party be liable to any other Party for incidental, consequential, or indirect damages arising out of or resulting from the performance under, or brought in connection with, this Contract whether arising in contract, tort, or otherwise.

7.12 All WAPA transfers and exports of RECs are final and cannot be reversed.

7.13 Valley City and MRES are responsible for ensuring RECs transferred or exported pursuant to this Contract are not double counted, and WAPA disclaims any responsibility therefor.

7.14 WAPA makes no warranties or guarantees that the RECs associated with Federal hydropower meet any Federal, state, or local standards.

7.15 Valley City's and MRES's right to claim, hold, resell, or otherwise use RECs is only for the term of the FES Contract.

8. BILLING AND PAYMENT PROVISIONS:

8.1 Prior to the transfer and/or export of RECs, WAPA shall bill MRES/Valley City, and MRES/Valley City shall make electronic payment annually, in advance, as instructed on the Bill for Collection, pay for any tracking system costs assessed to WAPA associated with the transfer or export of RECs to MRES on Valley City's behalf, as applicable. As stated above in Subsection 7.4, as of the execution date of this Contract, there are no fees for transfers between M-RETS accounts.

8.2 Actual cost accounting shall be utilized in this Contract. WAPA shall keep detailed records of actual costs incurred by WAPA to transfer and/or export of RECs. If costs are projected to exceed the amount of advanced funds, WAPA will inform MRES of the additional cost and provide a written revised estimate, together with a Bill for Collection, for the difference. MRES shall then pay WAPA the additional amount by the due date specified on the Bill for Collection. If, upon completion of the transfer or export, costs incurred by WAPA are less than the sum of the payments made to WAPA by MRES, WAPA shall refund the difference to MRES, without interest, as soon as the necessary vouchers can be processed.

8.32 WAPA will not transfer and/or export RECs until advance ~~annual~~ payment is received.

8.3 WAPA reserves the right to charge an additional administrative fee at its own discretion. WAPA shall notify Valley City before charging an administrative fee associated with the transfer and/or export of RECs.

9. GENERAL POWER CONTRACT PROVISIONS: The GPCP, effective ~~September 1, 2007~~ July 17, 2025, attached hereto, are made part of this Contract the same as if they had been expressly set forth herein except that Provisions 2 through 16, 18 through 30, 33, and 36 shall not apply.

10. NO THIRD-PARTY BENEFICIARIES: There are no intended third-party beneficiaries of this Contract. Nothing in this Contract shall be construed to create any duty to, any standard of care with reference to, or any liability to, any person or entity not a Party to this Contract.

11. USE OF DIGITAL SIGNATURES: The Parties agree that this Contract may be signed and executed by digital signature in accordance with WAPA's policy. A digital signature is the same as a handwritten signature and shall be considered valid and acceptable.

12. EXECUTION IN COUNTERPARTS: This Contract may be executed in any number of counterparts and, upon execution and delivery by each Party, the executed and delivered counterparts together shall have the same force and effect as an original instrument as if all Parties had signed the same instrument. Any signature page of this Contract may be detached by any counterpart of this Contract without impairing the legal effect of any signatures thereon, and may be attached to another counterpart of this Contract identical in form hereto, by having attached to it one or more signature pages.

IN WITNESS WHEREOF, the Parties have caused this Contract to be executed the day and year first above written.

WESTERN AREA POWER ADMINISTRATION

By _____

Title Vice President of Power Marketing

for Upper Great Plains Region

Address P.O. Box 35800

Billings, MT 59107-5800

(SEAL)

CITY OF VALLEY CITY, NORTH DAKOTA

Contract No. [2325-UGPR-15495](#)
City of Valley City, North Dakota
Missouri Basin Municipal Power
Agency d.b.a. Missouri River
Energy Services

By _____

Attest: Title _____

By _____ Address [P.O. Box 390220 3rd St. NE](#)

Title _____ Valley City, ND 58072-0390

(SEAL)

MISSOURI BASIN MUNICIPAL POWER AGENCY
D.B.A. MISSOURI RIVER ENERGY SERVICES

By _____

Attest: Title _____

By _____ Address P.O. Box 88920

Title _____ Sioux Falls, SD 57109-8920

DRAFT

CERTIFICATE

I, _____, certify that I am the _____
of the Missouri Basin Municipal Power Agency d.b.a. Missouri River Energy Services,
the corporation named as Contractor or MRES herein; that _____,
who signed the above Contract on behalf of MRES, was then its
_____; that such Contract was duly signed for and on
behalf of MRES by authority of its governing body and is within the scope of its
governmental powers.

Signature

(SEAL)



STATE OF NORTH DAKOTA
DEPARTMENT OF EMERGENCY SERVICES

Kelly Armstrong

Governor

Brigadier General Mitchell Johnson

Adjutant General - Director Department of Emergency Services

Darin Hanson

Director - Division of Homeland Security

Justin Messner

Disaster Recovery Chief

CFDA Title and Number: Disaster Grants – Public Assistance, 97.036

Disaster Declaration Number: FEMA-4888-DR

Subgrantee: City of Valley City

**Public Assistance Grant Program Subgrant Agreement
for
FEMA-4888-DR**

This Agreement is between the State of North Dakota, Department of Emergency Services (Grantee) and, the undersigned state agency, political subdivision of the state, private nonprofit organization, or federally recognized Tribal Nation or authorized tribal organization (Subgrantee). This Agreement is based on the existence of the following facts and conditions:

- A. WHEREAS, President Donald Trump issued a major disaster declaration (FEMA-4888-DR) for the State of North Dakota. The declaration authorized Public Assistance, as well as federal monies under the Hazard Mitigation Grant Program for counties designated eligible in the Federal Emergency Management Agency (FEMA)-State Agreement; and
- B. WHEREAS, the Grantee represents that it is fully qualified and eligible to receive these grant funds to provide the services identified herein and agrees to comply with all the requirements of this Agreement; and

- C. WHEREAS, pursuant to the North Dakota Disaster Act of 1985 as amended, the Grantee has authority to administer federal financial assistance from the FEMA consequent to a presidential declaration of disaster.
- D. WHEREAS, Subgrantee has the legal authority to accept public assistance funds and shall provide all necessary financial and managerial resources to meet the terms and conditions of receiving federal and state public assistance funds.

NOW, THEREFORE, the Grantee and Subgrantee, based upon the existence of the foregoing conditions, do further agree to the following:

ARTICLE I. Definitions. As used in this Agreement, the following terms shall have the following meanings unless another meaning is specified elsewhere:

- A. "Eligible activities" are those activities authorized in the FEMA-State Agreement, and in the Robert T. Stafford Disaster Relief and Emergency Assistance Act, Public Law 93-288, as amended, 42 U.S.C §§ 5121-5207 (Stafford Act); in accordance with 44 CFR § 206.44; and applicable policies of the FEMA.
- B. "FEMA-State Agreement" is the agreement between the FEMA and the State of North Dakota, for a presidential major disaster declaration designated FEMA-4888-DR.

ARTICLE II. Applicable Law. The parties agree to all the conditions, obligations, and duties imposed by the FEMA-State Agreement and all applicable state and federal legal requirements including, without any limitation on the generality of the foregoing, the requirements of Title 2 of the Code of Federal Regulations (CFR) Part 200, 44 CFR Part(s) 13 and 206, and the policies of the FEMA. The Subgrantee further agrees to comply with the Statement of Assurances attached hereto as Attachment A.

ARTICLE III. Funding and Insurance. Grantee shall provide funds to the Subgrantee for eligible activities for the projects approved by the Grantee and the FEMA, as specified in the approved Project Worksheets. The federal allowable costs shall be determined as per 2 CFR Part 200, which shall be seventy-five percent of all eligible costs unless a higher percentage is approved.

- A. The approved Project Worksheets shall be transmitted to Subgrantee, and shall state the cumulative funding allowed, the scope of the eligible project, and the costs eligible under this Agreement. Project Worksheets may obligate or deobligate funding, thereby amending the total funding for the project. The approved Project Worksheets shall document the total eligible costs and the total federal share of those costs, which shall be seventy-five percent of all eligible costs, unless a higher percentage is approved. Contingent upon an appropriation by the State Legislature, the Grantee may provide some portion of any nonfederal share for some subgrantees. As a condition of receipt of the federal funding, the Subgrantee agrees to provide any nonfederal share not paid by the Grantee.
- B. If the Subgrantee is required to repay the Grantee funds already disbursed by the Grantee, the Subgrantee will have 60 days to reimburse the full amount. If Subgrantee has not reimbursed the grantee the full amount within the 60 days, the Grantee will have all the rights and remedies available to them by law; including, but not limited to, the withhold of future fund disbursement to off-set amount due to Grantee.
- C. As a further condition to funding under this Agreement, the Subgrantee agrees to procure insurance sufficient for the type or types of hazards for which the disaster was declared to cover any and all projects to be funded under this Agreement where insurance is available and reasonable. Subgrantee shall provide Grantee with a certificate of such insurance as a condition to funding under this Agreement.

ARTICLE IV. Duplication of Benefits Prohibition. Subgrantee may not receive funding under this Agreement to pay for damage covered by insurance, nor may Subgrantee receive any other duplicate benefits under this Agreement.

- A. Without delay, Subgrantee shall advise Grantee of any insurance coverage for the damage identified on the applicable Project Worksheets and of any entitlement to compensation or indemnification from such insurance. All such duplicate benefits are “ineligible costs” which the Subgrantee shall reimburse to the Grantee without delay. The Subgrantee shall also reimburse the Grantee if the Subgrantee receives any duplicate benefits from any other source for any damage identified on the applicable Project Worksheets for which Subgrantee has received payment from Grantee.
- B. In the event that Grantee should determine that Subgrantee has received duplicate benefits, by its execution of this Agreement the Subgrantee gives Grantee the authority to set off the sum of any such duplicate benefits by withholding it from any other funds otherwise due and owing to Subgrantee, or to use such remedies available at law or equity to the repayment of said sums to Grantee.

ARTICLE V. Compliance with Environmental, Planning and Permitting Laws. Subgrantee shall be responsible for the implementation and completion of the approved projects described in the Project Worksheets in a manner acceptable to Grantee, and in accordance with applicable legal requirements. The contract documents for any project undertaken by Subgrantee, and any land use permitted by or engaged in by Subgrantee, shall be consistent with the local ordinances and State law. Subgrantee shall ensure that any development or development order complies with all applicable planning, permitting and building requirements. Subgrantee shall engage such competent, properly licensed engineering, building, and other technical and professional assistance at all project sites as may be needed to ensure that the project complies with the contract documents.

ARTICLE VI. Subgrantee Risk Assessment. As required by 2 CFR § 200.331 NDDDES will complete a Financial Assistance Recipient Risk Assessment rating form for every subgrantee receiving an award, to evaluate their potential risk of non-compliance. Subgrantees will be evaluated on factors such as their prior experience with the same or similar subawards, results of previous audits including whether or not they received a Single Audit and the extent to which the same or similar subaward has been audited as a major program; if they have new personnel or new or substantially changed systems, and the extent and results of Federal awarding agency monitoring.

A Risk Assessment will be completed immediately prior to executing this Subgrant Agreement. All new and existing active subgrantees will be rated upon new disaster and program funding opportunities. The Business Manager will work with the PA Officer, or assigned staff, to jointly complete the risk assessment and score subgrantees, as applicable. Results of the Risk Assessment may result in the imposition of specific conditions as allowed in 2 CFR § 200.207 and will be identified within Attachment B of this Subgrant Agreement.

Every January NDDDES will re-evaluate subgrantees that are designated medium or high risk. Based on compliance with special conditions and an updated Financial Assistance Recipient Risk Assessment, subgrantees may be upgraded or removed from medium or high-risk status. If a subgrantee is non-compliant with the additional requirements of a subaward due to being considered medium or high risk, the subaward and all federal and state monies can be deobligated at the request of NDDDES. Upon deobligation due to non-compliance, a subgrantee will be considered high risk in perpetuity.

ARTICLE VII. Required Documentation, Reviews, and Inspections. Subgrantee shall create and maintain documentation of work performed and costs incurred sufficient to permit a formal audit

comporting with ordinary, customary and prudent public accounting requirements. Upon the failure of Subgrantee to create and maintain such documentation, Grantee may terminate further funding under this Agreement, and Subgrantee shall reimburse to Grantee (within 60 days) all payments disbursed earlier to Subgrantee, together with any and all accrued interest.

- A. For all Small Projects and in accordance with the NDDDES Public Assistance Small Project Monitoring Policy, Grantee will inspect Small Projects by random selection. After inspection Subgrantee shall submit a signed "Public Assistance Small Project Funding Certification".
- B. For all Large Projects, as identified by NDDDES, the Grantee will conduct final inspections to ensure that all work has been performed within the scope of work specified on the Project Worksheets. Costs not within the approved scope of work shall not be reimbursed.
- C. Subgrantee shall submit the following documentation for Large Projects as identified by NDDDES (For this declaration, any project worksheets written for a single, complex "Work to be Completed" site that is estimated to cost more than \$200,000 will be considered a Large Project. Any projects written for numerous, smaller disaster sites will be viewed as small projects until they exceed the federal Large Project threshold of \$1,062,900).
 1. a request for reimbursement;
 2. a summary of documentation, which shall be supported by original documents such as contract documents, invoices, purchase orders, change orders, and proof of payment;
 3. a request for project closeout;

ARTICLE VIII. Cost Sharing. The federal share of the eligible costs specified in the Project Worksheets under this Agreement shall be seventy-five (75) percent of such costs, unless a higher percentage is approved, and the nonfederal share shall be the remaining amount. Payment of all or a specified portion of the nonfederal share of such costs is contingent upon a potential future State appropriation defining the apportionment of the nonfederal share. Subgrantee commits to meet any local matching funds required for successful project completion. Subgrantee also certifies that any matching funds borne by the Subgrantee will come from a nonfederal source as required by 2 CFR 200.306

ARTICLE IX. Payment of Costs. Grantee shall disburse the eligible costs to Subgrantee in accordance with the following procedures:

- A. Grantee shall disburse the federal and nonfederal shares of the eligible costs for Small Projects to Subgrantee as soon as practicable after execution of this Agreement and formal notification by FEMA of its approval of the pertinent Project Worksheet.
- B. Grantee shall reimburse Subgrantee for the full federal share of the eligible costs for Large Projects as soon as practicable after Subgrantee has delivered the following documents to Grantee:
 1. a Request for Reimbursement
 2. a summary of documentation, which shall be supported by original documents such as contract documents, invoices, purchase orders, change orders, and proof of payment;
 3. Certification that the reported costs were incurred in the performance of eligible work.
- C. Grantee may advance funds under this Agreement to Subgrantee not exceeding the federal share if Subgrantee meets the following conditions:
 1. Subgrantee shall certify to Grantee that Subgrantee has procedures in place to ensure that funds are disbursed to project vendors, contractors, and subcontractors without unnecessary delay;
 2. Subgrantee shall submit to Grantee the budget supporting the request;
 3. Subgrantee shall submit a statement justifying the advance and the proposed use of the funds and specifying the amount of funds requested; and

4. Subgrantee shall pay over to Grantee any interest earned on advances for remittance to the FEMA as often as practicable, but not later than ten (10) business days after the close of each calendar quarter.
- D. Grantee may, in its discretion, pay some or its entire portion of the nonfederal share when the NDDDES Director, Division of Homeland Security, authorizes such payments.
- E. Grantee may, in its discretion, withhold its portion of the nonfederal share of funding under this Agreement from Subgrantee if Grantee has reason to expect a subsequent unfavorable determination by the FEMA that a previous disbursement of funds under this Agreement was improper.

ARTICLE X. Final Payment. Grantee shall disburse the final payment to Subgrantee upon the performance of the following conditions:

- A. Subgrantee shall have requested final reimbursement;
- B. Subgrantee shall have submitted the documentation specified in Articles VII and IX of this Agreement;
- C. Subgrantee shall have completed the project to the satisfaction of the Grantee;
- D. In the case of Large Projects, the Grantee shall have performed the final inspection; or
- E. In the case of Small Projects, the NDDDES Small Project Monitoring Team shall have performed a compliance review; and
- F. When necessary, FEMA Closeout shall be completed.

ARTICLE XI. Records Maintenance. The funding of eligible costs under this Agreement and the performance of all other conditions shall be subject to the following requirements, in addition to such other and further requirements as may be imposed by operation of law:

- A. The "Uniform Administrative Requirements for Grants and Cooperative Agreements to State and Local Governments," as codified in 2 Code of Federal Regulations Part 200.333.
- B. Subgrantee shall retain sufficient records to show its compliance with the terms of this Agreement, as well as the compliance of all subcontractors or consultants paid from funds under this Agreement for a period of three years from the date of formal notification from the Grantee that FEMA has officially closed the disaster program. The Subgrantee shall allow the Grantee or its designee, the Comptroller General of the United States, FEMA, and the North Dakota State Auditor's Office, access to records upon request. The three year period may be extended for the following exceptions:
 1. If any litigation, claim or audit is started before the three year period expires, and extend beyond the three year period, the records shall be retained until all litigation, claims or audit findings involving the records have been resolved.
 2. Records for the disposition of non-expendable personal property valued at \$5,000 or more at the time it is acquired shall be retained for five years after final disposition.
 3. Records relating to real property acquired shall be retained for five years after the closing on the transfer of title.
- C. The Subgrantee shall maintain all records for the Subgrantee and for all subcontractors or consultants to be paid from funds provided under this Agreement, including documentation of all program costs, in a form sufficient to determine compliance with the requirements and objectives under this Agreement and all other applicable laws and regulations.
- D. The Subgrantee, its employees or agents, including all subcontractors or consultants to be paid from funds provided under this Agreement, shall allow access to its records at reasonable times to the Grantee, its employees, and agents. "Reasonable" shall ordinarily mean during normal business hours of 8:00 a.m. to 5:00 p.m., local time, on Monday through Friday. "Agents" shall include, but not be limited to, auditors retained by the Grantee.

ARTICLE XII. Reimbursement of Funds. If upon final inspection, final audit, or other review by Grantee, the FEMA or other authority determines that the disbursements to Subgrantee under this Agreement exceed the eligible costs, Subgrantee shall reimburse to Grantee the sum by which the total disbursements exceed the eligible costs within sixty (60) days from the date Subgrantee is notified of such determination. If Subgrantee has not reimbursed the grantee the full amount within the 60 days, the Grantee will have all the rights and remedies available to them by law; including, but not limited to, the withhold of future fund disbursement to off-set amount due to Grantee.

ARTICLE XIII. Repayment by Subgrantee. All refunds or repayments due to the Grantee under this Agreement are to be made payable to the order of “**North Dakota Department of Emergency Services**” and mailed directly to the following address: **PO Box 5511, Bismarck, ND, 58506.**

ARTICLE XIV. Audit.

- A. The Subgrantee agrees to maintain financial procedures and support documents, in accordance with generally accepted accounting principles, to account for the receipt and expenditure of funds under this Agreement.
- B. These records shall be available at all reasonable times for inspection, review, or audit by state personnel and other personnel duly authorized by the Grantee. "Reasonable" shall be construed according to circumstances, but ordinarily shall mean normal business hours of 8:00 a.m. to 5:00 p.m., local time, Monday through Friday.
- C. The Subgrantee shall also provide the Grantee or its designee with the records, reports or financial statements upon request for the purposes of auditing and monitoring the funds awarded under this Agreement.
- D. If the Subgrantee expends \$1,000,000 or more in federal funds during their fiscal year, then the Subgrantee shall have a single or program specific audit conducted which meets the requirements of the 2 CFR Part 200, Subpart F for the purposes of auditing and monitoring the funds awarded under this Agreement. In connection with the aforementioned audit requirement, the Subgrantee shall fulfill for auditee responsibilities as provided in Subpart F of 2 CFR Part 200.
- E. If the Subgrantee spends less than \$1,000,000 in federal awards in its fiscal year, an audit conducted in accordance with the provision of 2 CFR Part 200 Subpart F is not required. In the event the Subgrantee expends less than \$1,000,000 in federal awards in its fiscal year and chooses to have an audit conducted in accordance with 2 CFR Part 200 Subpart F, the cost of the audit must be paid from nonfederal funds.
- F. In the event the audit shows that the entire funds disbursed hereunder, or any portion thereof, were not spent in accordance with the conditions of this Agreement, the Subgrantee shall be held liable for reimbursement to the Grantee of all funds not spent in accordance with these applicable regulations and Agreement provisions within sixty (60) days after the Grantee has notified the Subgrantee of such non-compliance.
- G. If required, the audit is due nine (9) months after the end of the fiscal year of Subgrantee.
- H. If audit is conducted as required, the Subgrantee shall submit the single audit reporting package to the Federal Audit Clearinghouse at <https://harvester.census.gov/facweb/>. If the audit documents any finding or questioned costs, Subgrantee shall submit a copy of the reporting package to the State at the following address:

ND Department of Emergency Services
PO Box 5511
Bismarck ND 58506

ARTICLE XV. Noncompliance. If the Subgrantee violates this Agreement or any legislation, regulation, statute, rule or other legal requirement applicable to the performance of this Agreement, the Grantee may withhold any disbursement otherwise due Subgrantee for the project with respect to which the violation has occurred until the violation is cured or has otherwise come to final resolution. If the violation is not cured, Grantee may terminate this Agreement and invoke its remedies under the Agreement as per the Articles of this Agreement.

ARTICLE XVI. Nondiscrimination by Contractors. Pursuant to 44 CFR Parts 7 and 16, and 44 CFR Part 206.36, the Subgrantee shall undertake an active program of nondiscrimination in its administration of disaster assistance under this Agreement. Subgrantee shall also be subject to the requirements in the General Services Administrative Consolidated List of Debarred, Suspended and Ineligible Contractors, in accordance with 44 CFR Part 17.

ARTICLE XVII. Modification. A modification extending the time for completion of the project and any other modification shall be in writing and shall take effect only upon execution by both parties. Modifications to any Project Worksheet to be funded under this Agreement may be requested by Subgrantee through Grantee, but the approval of any such modifications shall reside in the sole discretion of the Federal Emergency Management Agency. Any approved modification to a Project Worksheet shall be noted in an additional Project Worksheet version for the project and in any amendment to this Agreement. If otherwise allowed under this Agreement, any extension shall be in writing and shall be subject to the same terms and conditions as those set out in the initial Agreement.

ARTICLE XVIII. Time for Performance. Subject to any modification extending the time for the performance of this Agreement approved by Grantee or the FEMA, the time for the performance of emergency work shall be six (6) months from the date of the Presidential Declaration. The time for the performance of permanent work shall be eighteen (18) months from the date of the Presidential Declaration. The time for the performance of this Agreement may be extended for cause by Grantee. Extensions shall not be approved for delays caused by lack of cost-share funding. If any extension request is denied, Subgrantee shall be reimbursed for eligible project costs incurred up to the latest approved date for timely completion. Failure to complete any project will be adequate cause for the termination of funding for that project.

ARTICLE XIX. Contracts with Others. If the Subgrantee contracts with any other contractor or vendor for performance of all or any portion of the work required under this Agreement, the Subgrantee shall incorporate into its contract with such contractor or vendor an indemnification clause holding Grantee and Subgrantee harmless from liability to third parties for claims asserted under such contract.

ARTICLE XX. Termination. Either of the parties may terminate this Agreement by notice in writing. Such termination shall take effect thirty (30) days after the date of such notice. Such termination shall not affect the rights, interests, duties or responsibilities of either of the parties or any allowable costs that have accrued as of the date of the notice of termination.

ARTICLE XXI. Liability. Grantee assumes no liability to third parties in connection with this agreement. The Subrecipient shall be solely responsible to any and all contractors, vendors, and other parties with whom it contracts in performing this Agreement. Unless the Subrecipient is a political subdivision under NDCC 32-12.2-13, or a North Dakota State Agency, the Subrecipient shall defend, indemnify and hold harmless Grantee from claims asserted by third parties in connection with the performance of this Agreement. The ND Department of Emergency Services and the Political Subdivision or State Agency, who are the parties to this agreement, each agree to assume its own liability for any and all claims of any nature including all costs, expenses and

attorneys' fees which may in any manner result from or arise out this agreement and the project that is the subject of this agreement. Contractors hired by a Subrecipient, including political subdivisions, shall be required to agree in writing to defend, indemnify and hold the State of North Dakota harmless for any claims arising out the contractor's or any subcontractor's performance under the agreement. For the purposes of this Agreement, the Grantee and Subrecipient agree that neither one is an employee or agent of the other, but that each one stands as an independent entity in relation to one another. Nothing in this Agreement shall be construed as a waiver by the Grantee or Subrecipient of any legal immunity, nor shall anything in this Agreement be construed as consent by either of the parties to be sued by third parties in connection with any matter arising from the performance of this Agreement. Subrecipient represents to the best of its knowledge any hazardous substances at its projected site or sites are present in quantities within statutory and regulatory limitations, and do not require remedial action under any federal, state or local legal requirements concerning such substances, Subrecipient further represents that the presence of any such substance or any condition at the site caused by the presence of any such substance shall be addressed in accordance with all applicable legal requirements.

ARTICLE XXII. Reports. Grantee is required to submit a Large Project Quarterly Report to FEMA for Large Projects for which a FEMA Large Project Closeout has not been completed. The progress report will include: the status of the project, such as "in design" or "percentage of construction completed"; time extensions granted, if any; a projected completion date; the amount of expenditures and amount of payment for each project; and any problems or circumstances that could delay the project or result in noncompliance with the conditions of the FEMA approval. When the FEMA Large Project Closeout for each large project is complete, the project may be dropped from the report. Periodically, Grantee may request information or reports from the Subgrantee for inclusion in the Large Project Quarterly Report. Subgrantee is required to provide information or reports as soon as practicable after requested. Interim inspections may be scheduled by Subgrantee before the final inspection and may be required by Grantee. Grantee may require additional reports as needed, and Subgrantee shall provide any additional reports requested by Grantee as soon as practicable.

ARTICLE XXIII. Monitoring. The Subgrantee shall monitor its performance under this Agreement, as well as that of its subcontractors, Subgrantees and consultants who are paid from funds provided under this Agreement, to ensure that performance under this Agreement are achieved and satisfactorily performed and in compliance with applicable state and federal laws and rules.

In addition to reviews of audits conducted in accordance with 2 CFR Part 200 Subpart F, monitoring procedures may include, but not be limited to, on-site visits by Grantee staff, limited scope audits as defined by 2 CFR Part 200 Subpart F, and/or other procedures. By entering into this Agreement, the Subgrantee agrees to comply and cooperate with all monitoring procedures/processes deemed appropriate by the Grantee. In the event that the Grantee determines that a limited scope audit of the Subgrantee is appropriate, the Subgrantee agrees to comply with any additional instructions provided by the Grantee to the Subgrantee regarding such audit. The Subgrantee further agrees to comply and cooperate with any inspections, reviews, investigations or audits deemed necessary by the Comptroller or Auditor General. In addition, the Grantee will monitor the performance and financial management by the Subgrantee throughout the contract term to ensure timely completion of all tasks.

ARTICLE XXIV. Mandated Conditions. Subgrantee agrees to the following conditions:

- A. The performance and obligation of Grantee to pay under this Agreement is contingent upon an annual appropriation by the Legislature.

- B. Bills for fees or other compensation for services or expenses must be submitted in detail sufficient for a proper pre-audit and post-audit.
- C. Grantee may unilaterally terminate this Agreement for refusal by the Subgrantee or its contractors or subcontractors to allow public access to all documents, papers, letters or other material, that are made or received by Subgrantee or its contractors and subcontractors in connection with this Agreement.
- D. Subgrantee agrees that no funds or other resources received from the Grantee disbursed to it under this Agreement will be used directly or indirectly to influence legislation or any other official action by the North Dakota Legislature or any state agency.
- E. Subgrantee certifies that it possesses the legal authority to receive the funds under this Agreement and that it's governing body (if applicable) has authorized the execution and acceptance of this Agreement. The Subgrantee also certifies that the undersigned person has the authority to legally execute and bind Subgrantee to the terms of this Agreement.
- F. Subgrantee agrees that responsibility for compliance with this Agreement rests with Subgrantee, and further agrees that noncompliance with this Agreement shall be cause for the rescission, suspension or termination of funding under this Agreement, and may affect eligibility for funding under future Subgrantee Agreements.
- G. The Grantee will not intentionally award publicly funded contracts to any contractor who knowingly employs unauthorized alien workers, constituting a violation of the employment provisions contained in 8 U.S.C. Section 1324a(e) [Section 274A(e) of the Immigration and Nationality Act ("INA")]. The Department shall consider the employment by any contractor of unauthorized aliens a violation of Section 274A(e) of the INA. Such violation by the Subgrantee of the employment provisions contained in Section 274A(e) of the INA shall be grounds for unilateral cancellation of this Agreement by the Department.
- H. A person or affiliate who has been placed on the convicted vendor list following a conviction for a public entity crime or on the discriminatory vendor list may not submit a bid on a contract to provide any goods or services to a public entity, may not submit a bid on a contract with a public entity for the construction or repair of a public building or public work, may not submit bids on leases of real property to a public entity, may not be awarded or perform work as a contractor, supplier, subcontractor, or consultant under a contract with a public entity, and may not transact business with any public entity in excess of Category Two for a period of 36 months from the date of being placed on the convicted vendor list or on the discriminatory vendor list.
- I. The Subgrantee agrees to comply with the Americans With Disabilities Act (Public Law 101-336, 42 U.S.C. Section 12101 et seq.), if applicable, which prohibits discrimination by public and private entities on the basis of disability in the areas of employment, public accommodations, transportation, State and local government services, and in telecommunications.
- J. With respect to any Subgrantee which is not a local government or state agency, and which receives funds under this Agreement from the federal government, by signing this Agreement, the Subgrantee certifies, to the best of its knowledge and belief, that it and its principals:
 - 1. are not presently debarred, suspended, proposed for debarment, declared ineligible, or voluntarily excluded from covered transactions by a federal department or agency;
 - 2. have not, within a five-year period preceding this proposal been convicted of or had a civil judgment rendered against them for:
 - a) The commission of fraud or a criminal offense in connection with obtaining, attempting to obtain, or performing a public (federal, state or local) transaction or contract under public transaction.
 - b) Violation of federal or state antitrust statutes or commission of embezzlement, theft, forgery, bribery, falsification or destruction of records, making false statements, or receiving stolen property.

- c) Have not within a five-year period preceding this Agreement had one or more public transactions (federal, state or local) terminated for cause or default.

Where the Subgrantee is unable to certify to any of the statements in this certification, such Subgrantee shall attach an explanation to this Agreement. In addition, the Subgrantee shall submit to the Grantee (by email or facsimile) the completed "Certification Regarding Debarment, Suspension, Ineligibility and Voluntary Exclusion" for each prospective subcontractor which Subgrantee intends to fund under this Agreement. See Attachment B. Such form must be received by the Grantee prior to the Subgrantee entering into a contract with any prospective subcontractor.

- K. The validity of this Agreement is subject to the truth and accuracy of all the information, representations, and materials submitted or provided by the Subgrantee in this Agreement, in any subsequent submission or response to Grantee request, or in any submission or response to fulfill the requirements of this Agreement, and such information, representations, and materials are incorporated by reference. The lack of accuracy thereof or any material changes shall, at the option of the Department and with thirty (30) days written notice to the Subgrantee, cause the termination of this Agreement and the release of the Grantee from all its obligations to the Subgrantee.
- L. This Agreement shall be construed under the laws of the State of North Dakota, and venue for any actions arising out of this Agreement shall lie in Burleigh County. If any provision hereof is in conflict with any applicable statute or rule, or is otherwise unenforceable, then such provision shall be deemed null and void to the extent of such conflict, and shall be deemed severable, but shall not invalidate any other provision of this Agreement.
- M. The Subgrantee certifies, by its signature to this Agreement, that to the best of his or her knowledge and belief:
 - 1. No federal appropriated funds have been paid or will be paid, by or on behalf of the undersigned, to any person for influencing or attempting to influence an officer or employee of any agency, a Member of Congress, an officer or employee of Congress, or an employee of a Member of Congress in connection with the awarding of any federal contract, the making of any federal grant, the making of any federal loan, the entering into of any cooperative agreement, and the extension, continuation, renewal, amendment or modification of any federal contract, grant, loan or cooperative agreement.
 - 2. If any funds other than federal appropriated funds have been paid or will be paid to any person for influencing or attempting to influence an officer or employee of any agency, a Member of Congress, an officer or employee of Congress, or an employee of a Member of Congress in connection with this federal contract, grant, loan or cooperative agreement, the undersigned shall complete and submit Standard Form-LLL, "Disclosure Form to Report Lobbying," in accordance with its instructions.
 - 3. The undersigned shall require that the language of this certification be included in the award documents for all sub awards at all tiers (including subcontracts, sub grants, and contracts under grants, loans, and cooperative agreements) and that all sub grantees shall certify and disclose accordingly. This certification is a material representation of fact upon which reliance was placed when this transaction was made or entered into. Submission of this certification is a prerequisite for making or entering into this transaction imposed by Section 1352, Title 31, U.S. Code. Any person who fails to file the required certification shall be subject to a civil penalty of not less than \$10,000 and not more than \$100,000 for each such failure.
- O. All unmanufactured and manufactured articles, materials and supplies which are acquired for public use under this Agreement have been produced in the United States as required 41 U.S.C. 10a, unless it would not be in the public interest or unreasonable in cost.

ARTICLE XXV. Term. This Agreement shall take effect upon its execution by both parties and shall terminate upon approval of closeout by the FEMA, unless terminated earlier as specified elsewhere in this Agreement. Subgrantee shall commence approved project(s) specified by this Agreement without delay.

ARTICLE XXVI. Events of Default, Remedies, and Termination.

- A. Upon the occurrence of any one or more of the following events, all obligations of Grantee to disburse further funds under this Agreement shall terminate at the option of Grantee. Notwithstanding the preceding sentence, Grantee may at its option continue to make payments or portions of payments after the occurrence of any one or more such events without waiving the right to exercise such remedies and without incurring liability for further payment. Grantee may at its option terminate this Agreement and any and all funding under this Agreement upon the occurrence of any one or more of the following:
1. Any representation by Subgrantee in this Agreement is inaccurate or incomplete in any material respect, or Subgrantee has breached any condition of this Agreement with Grantee and has not cured in timely fashion or is unable or unwilling to meet its obligations under this Agreement.
 2. Subgrantee suffers any material adverse change in its financial condition while this Agreement is in effect, as compared to its financial condition as represented in any reports or other documents submitted to Grantee, if Subgrantee has not cured the condition within thirty (30) days after notice in writing from Grantee.
 3. Any reports required by this Agreement have not been submitted to Grantee or have been submitted with inaccurate, incomplete, or inadequate information.
 4. The monies necessary to fund this Agreement are unavailable due to any failure to appropriate or other action or inaction by the State Legislature, Congress or Office of Management and Budget.
- B. Upon the occurrence of any one or more of the foregoing events, Grantee may at its option give notice in writing to Subgrantee to cure its failure of performance if such failure may be cured. Upon the failure of Subgrantee to cure, Grantee may exercise any one or more of the following remedies:
1. Terminate this Agreement upon not less than fifteen (15) days notice of such termination by certified letter to the Subgrantee, such notice to take effect when delivered to Subgrantee;
 2. Commence a legal action for the judicial enforcement of this Agreement;
 3. Withhold the disbursement of any payment or any portion of a payment otherwise due and payable under this agreement or any other agreement with Subgrantee; and
 4. Take any other remedial actions that may otherwise be available under law.
- C. Grantee may terminate this Agreement for any misrepresentation of material fact, for failure or nonperformance of any Agreement condition or obligation, or for noncompliance with any applicable legal requirement.
- D. Any deobligation of funds or other determination by the FEMA shall be addressed in accordance with the regulations of that Agency.
- E. Upon the rescission, suspension or termination of this Agreement, the Subgrantee shall refund to Grantee all funds disbursed to Subgrantee under this Agreement.
- F. The venue of any action or proceeding by either Grantee or Subgrantee for enforcement of this Agreement or for adjudication rights, interest, or duties of the parties to it shall lie in South Central District Court, Burleigh County, North Dakota.
- G. Notwithstanding anything to the contrary elsewhere in this Agreement, the rescission, suspension or termination of this Agreement by Grantee shall not relieve Subgrantee of liability to Grantee for the restitution of funds advanced to Subgrantee under this Agreement, and Grantee may set off any such funds by withholding future disbursements otherwise due Subgrantee under this

Agreement or any other Agreement until such time as the exact amount of restitution due Grantee from Subgrantee is determined. In the event the FEMA should deobligate funds formerly allowed under this Agreement or under any other Agreement funded by the Agency and administered by Grantee, then Subgrantee shall immediately repay such funds to Grantee. If the Subgrantee fails to repay any such funds, then Grantee may recover the same from funding otherwise due Subgrantee.

ARTICLE XXVII. Attachments.

- A. All attachments to this Agreement are incorporated into this Agreement by reference as if set out fully in the text of the Agreement itself.
- B. In the event of any inconsistencies between the language of this Agreement and the Attachments to it if any, the language of the Attachments shall be controlling, but only to the extent of such inconsistencies.

Note: All other grant administrative and electronic forms will be provided by Grantee as necessary or posted on the North Dakota Department of Emergency Services website: <http://www.nd.gov/des/>.

ARTICLE XXVIII. Notice and Contact. All notices under this Agreement shall be in writing and shall be delivered by email, by facsimile, by hand, or by letter to the following respective addresses:

Grantee:

Justin Messner, Disaster Recovery Chief
Department of Emergency Services
PO Box 5511
Bismarck, ND 58506
Email: jmessner@nd.gov

Subgrantee:

Brenda Klein, Deputy Auditor
City of Valley City
254 2nd Ave NE
Valley City, ND 58072
Email: bklein@valleycity.us

ARTICLE XXIX. Designation of Agent. Subgrantee hereby designates the following agents to execute any Request for Advance or Reimbursement, certification, or other necessary documentation:

Primary Agent

Alternate Agent

Name and Title

Name and Title

Phone Number

Phone Number

E-mail

E-mail

**STATE OF NORTH DAKOTA
DEPARTMENT OF EMERGENCY SERVICES**

SIGNATURE PAGE

**PUBLIC ASSISTANCE GRANT PROGRAM SUBGRANT AGREEMENT
FOR
(FEMA-4888-DR)**

IN WITNESS HEREOF, the Grantee and Subgrantee have executed this Agreement:

FOR THE SUBGRANTEE:

Name and Title

Signature

Date

Federal Employer Identification Number (FEIN): _____

UEI Number: _____

ATTACHMENT A

Statement of Assurances

To the extent the following provisions apply to this Agreement, the Subgrantee agrees to comply with the following:

1. Contract Work Hours and Safety Standards Act of 1962, 40 U.S.C. 327 et seq., requiring that mechanics and laborers (including watchmen and guards) employed on federally assisted contracts be paid wages of not less than one and one-half times their basic wage rates for all hours worked in excess of forty hours in a work week.
2. Federal Fair Labor Standards Act, 29 U.S.C. Section 201 et seq., requiring that covered employees be paid at least the minimum prescribed wage, and also that they be paid one and one-half times their basic wage rates for all hours worked in excess of the prescribed work-week.
3. Title VI of the Civil Rights Act of 1964 (P.L. 88-352), and the regulations issued pursuant thereto, which provides that no person in the United States shall on the grounds of race, color, or national origin, (including limited English proficiency per Executive Order 13166) be excluded from participation in, be denied the benefits of, or be otherwise subjected to discrimination under any program or activity for which the Subgrantee receives federal financial assistance and will immediately take any measures necessary to effectuate this assurance. If any real property or structure thereon is provided or improved with the aid of federal financial assistance extended to the Subgrantee, this assurance shall obligate the Subgrantee, or in the case of any transfer of such property, any transferee, for the period during which the real property or structure is used for a purpose for which the federal financial assistance is extended, or for another purpose involving the provision of similar services or benefits.
4. Any prohibition against discrimination on the basis of age under the Age Discrimination Act of 1975, as amended (42 U.S.C.: 6101-6107) which prohibits discrimination on the basis of age or with respect to otherwise qualified handicapped individuals as provided in Section 504 of the Rehabilitation Act of 1973.
5. Executive Order 11246 as amended by Executive Orders 11375 and 12086, and the regulations issued pursuant thereto, which provide that no person shall be discriminated against on the basis of race, color, religion, sex or national origin in all phases of employment during the performance of federal or federally assisted construction contracts; affirmative action to insure fair treatment in employment, upgrading, demotion, or transfer; recruitment or recruitment advertising; layoff/termination, rates of pay or other forms of compensation; and election for training and apprenticeship.
6. It will comply with the Anti-Kickback Act of 1986, 41 U.S.C. Section 51 which outlaws and prescribes penalties for "kickbacks" of wages in federally financed or assisted construction activities.
7. It will comply with the provisions of 18 USC 594, 598, 600-605 (further known as the Hatch Act) which limits the political activities of employees.
8. It will comply with the flood insurance purchase and other requirements of the Flood Disaster Protection Act of 1973 as amended, 42 USC 4002-4107, including requirements regarding the purchase of flood insurance in communities where such insurance is available as a condition for the receipt of any federal financial assistance for construction or acquisition purposes for use in any area having special flood hazards. The phrase "Federal financial assistance" includes any form of loan, grant, guaranty, insurance payment, rebate, subsidy, disaster assistance loan or grant, or any other form of direct or indirect federal assistance.

9. It will require every building or facility (other than a privately owned residential structure) designed, constructed, or altered with funds provided under this Agreement to comply with the "Uniform Federal Accessibility Standards," (AS) which is Appendix A to 41 CFR Section 101-19.6 for general type buildings and Appendix A to 24 CFR Part 40 for residential structures. The Subgrantee will be responsible for conducting inspections to ensure compliance with these specifications by the contractor.
10. It will, in connection with its performance of environmental assessments under the National Environmental Policy Act of 1969, comply with Section 106 of the National Historic Preservation Act of 1966 (U.S.C. 470), Executive Order 11593, 24 CFR Part 800, and the Preservation of Archaeological and Historical Data Act of 1966 (16 U.S.C. 469a-1, et seq.) by:
 - a) Consulting with the State Historic Preservation Office to identify properties listed in or eligible for inclusion in the National Register of Historic Places that are subject to adverse effects (see 36 CFR Section 800.8) by the proposed activity.
 - b) Complying with all requirements established by the state to avoid or mitigate adverse effects upon such properties.
 - c) When any of Subgrantee's projects funded under this Agreement may affect a historic property, as defined in 36 CFR 800. (2)(e), the FEMA may require Subgrantee to review the eligible scope of work in consultation with the State Historic Preservation Office (SHPO) and suggest methods of repair or construction that will conform with the recommended approaches set out in the "Secretary of Interior's Standards for Rehabilitation and Guidelines for Rehabilitating Historic Buildings 1992 (Standards), the Secretary of the Interior's Guidelines for Archeological Documentation (Guidelines) (48 Federal Register 44734-37)," or any other applicable Secretary of Interior standards. If FEMA determines that the eligible scope of work will not conform with the Standards, Subgrantee agrees to participate in consultations to develop, and, after execution by all parties, to abide by, a written agreement that establishes mitigation and recondition measures, including but not limited to, impacts to archeological sites, and the salvage, storage, and reuse of any significant architectural features that may otherwise be demolished.
 - d) Subgrantee agrees to notify FEMA and the Grantee if any project funded under this Agreement will involve ground disturbing activities, including, but not limited to: subsurface disturbance; removal of trees; excavation for footings and foundations; and installation of utilities (such as water, sewer, storm drains, electrical, gas, leach lines and septic tanks) except where these activities are restricted solely to areas previously disturbed by the installation, replacement or maintenance of such utilities. FEMA will request the SHPO's opinion on the potential that archeological properties may be present and be affected by such activities. The SHPO will advise Subgrantee on any feasible steps to be accomplished to avoid any National Register eligible archeological property or will make recommendations for the development of a treatment plan for the recovery of archeological data from the property. If Subgrantee is unable to avoid the archeological property, develop, in consultation with the SHPO, a treatment plan consistent with the Guidelines and take into account the Advisory Council on Historic Preservation (Council) publication "Treatment of Archeological Properties." Subgrantee shall forward information regarding the treatment plan to FEMA, the SHPO and the Council for review. If the SHPO and the Council do not object within 15 calendar days of receipt of the treatment plan, FEMA may direct Subgrantee to implement the treatment plan. If either the Council or the SHPO object, Subgrantee shall not proceed with the project until the objection is resolved.
 - e) Subgrantee shall notify the Grantee and FEMA as soon as practicable: (i) of any changes in the approved scope of work for a National Register eligible or listed property; (ii) of all

changes to a project that may result in a supplemental DSR or modify an HMGP project for a National Register eligible or listed property; (iii) if it appears that a project funded under this Agreement will affect a previously unidentified property that may be eligible for inclusion in the National Register or affect a known historic property in an unanticipated manner. Subgrantee acknowledges that FEMA may require Subgrantee to stop construction in the vicinity of the discovery of a previously unidentified property that may be eligible for inclusion in the National Register or upon learning that construction may affect a known historic property in an unanticipated manner. Subgrantee further acknowledges that FEMA may require Subgrantee to take all reasonable measures to avoid or minimize harm to such property until FEMA concludes consultation with the SHPO. Subgrantee also acknowledges that FEMA will require, and Subgrantee shall comply with, modifications to the project scope of work necessary to implement recommendations to address the project and the property.

- f) Subgrantee acknowledges that, unless FEMA specifically stipulates otherwise, it shall not receive funding for projects when, with intent to avoid the requirements of the NHPA, Subgrantee intentionally and significantly adversely affects a historic property, or having the legal power to prevent it, allowed such significant adverse affect to occur.
11. It will comply with Title IX of the Education Amendments of 1972, as amended (20 U.S.C.: 1681-1683 and 1685 - 1686) which prohibits discrimination on the basis of sex.
12. It will comply with the Comprehensive Alcohol Abuse and Alcoholism Prevention, Treatment and Rehabilitation Act of 1970, (42 U.S.C. 4521-45-94) relating to nondiscrimination on the basis of alcohol abuse or alcoholism.
13. It will comply with 523 and 527 of the Public Health Service Act of 1912 (42 U.S.C. 290 dd-3 and 290 ee-3), as amended, relating to confidentiality of alcohol and drug abuse patient records.
14. It will comply with Lead-Based Paint Poison Prevention Act (42 U.S.C.: 4821 et seq.) which prohibits the use of lead based paint in construction of rehabilitation or residential structures.
15. It will comply with the Energy Policy and Conservation Act (P.L. 94-163; 42 U.S.C. 6201-6422), and the provisions of the state Energy Conservation Plan adopted pursuant thereto.
16. It will comply with the Laboratory Animal Welfare Act of 1966, 7 U.S.C. 2131-2159, pertaining to the care, handling, and treatment of warm blooded animals held for research, teaching, or other activities supported by an award of assistance under this agreement.
17. It will comply with Title VIII of the Civil Rights Act of 1968, 42 U.S.C. 2000c and 42 3601-3619, as amended, relating to non-discrimination in the sale, rental, or financing of housing, and Title VI of the Civil Rights Act of 1964 (P.L. 88-352), which prohibits discrimination on the basis of race, color or nation origin.
18. It will comply with the Clean Air Act of 1955, as amended, 42 U.S.C. 7401-7642.
19. It will comply with the Clean Water Act of 1977, as amended, 42 U.S.C. 7419-7626.
20. It will comply with the Endangered Species Act of 1973, 16 U.S.C. 1531-1544.
21. It will comply with the Intergovernmental Personnel Act of 1970, 42 U.S.C. 4728-4763.
22. It will assist the awarding agency in assuring compliance with the National Historic Preservation Act of 1966, as amended, 16 U.S.C. 270.
23. It will comply with environmental standards which may be prescribed pursuant to the National Environmental Policy Act of 1969, 42 U.S.C. 4321-4347.
24. It will assist the awarding agency in assuring compliance with the Preservation of Archeological and Historical Preservation Act of 1966, 16 U.S.C. 469a, et seq.
25. It will comply with the Rehabilitation Act of 1973, Section 504, 29 U.S.C. 794, regarding non-discrimination.
26. It will comply with the environmental standards which may be prescribed pursuant to the Safe Drinking Water Act of 1974, 42 U.S.C. 300f-300j, regarding the protection of underground water sources.

27. It will comply with the requirements of Titles II and III of the Uniform Relocation Assistance and Property Acquisition Policies Act of 1970, 42 U.S.C. 4621-4638, which provide for fair and equitable treatment of persons displaced or whose property is acquired as a result of federal or federally assisted programs.
28. It will comply with the Wild and Scenic Rivers Act of 1968, 16 U.S.C. 1271-1287, related to protecting components or potential components of the national wild and scenic rivers system.
29. It will comply with the following Executive Orders: EO 11514 (NEPA); EO 11738 (violating facilities); EO 11988 (Floodplain Management); EO 11990 (Wetlands); and EO 12898 (Environmental Justice).
30. It will comply with the Coastal Barrier Resources Act of 1977, 16 U.S.C. 3510.
31. It will assure project consistency with the approved state program developed under the Coastal Zone Management Act of 1972, 16 U.S.C. 1451-1464.
32. It will comply with the Fish and Wildlife Coordination Act of 1958; 16 U.S.C. 661-666.
33. With respect to demolition activities, it will:
 - a) Create and make available documentation sufficient to demonstrate that the Subgrantee and its demolition contractor have sufficient manpower and equipment to comply with the obligations as outlined in this Agreement.
 - b) Return the property to its natural state as though no improvements had ever been contained thereon.
 - c) Furnish documentation of all qualified personnel, licenses and all equipment necessary to inspect buildings located in Subgrantee's jurisdiction to detect the presence of asbestos and lead in accordance with requirements of the U.S. Environmental Protection Agency, the State health authority and the county health authority.
 - d) Provide documentation of the inspection results for each structure to indicate: safety hazards present; health hazards present; and/or hazardous materials present.
 - e) Provide supervision over contractors or employees employed by Subgrantee to remove asbestos and lead from demolished or otherwise applicable structures.
 - f) Leave the demolished site clean, level and free of debris.
 - g) Notify the Grantee promptly of any unusual existing condition which hampers the contractors work.
 - h) Obtain all required permits.
 - i) Provide addresses and marked maps for each site where water wells and septic tanks are to be closed along with the number of wells and septic tanks located on each site. Provide documentation of closures.
 - j) Comply with mandatory standards and policies relating to energy efficiency which are contained in the state energy conservation plan issued in compliance with the Energy Policy and Conservation Act (Public Law 94-163).
 - k) Comply with all applicable standards, orders, or requirements issued under Section 112 and 306 of the Clean Air Act (42 U.S.C. 1857 (h), Section 508 of the Clean Water Act (33 U.S. 1368), Executive Order 11738, and the U.S. Environmental Protection Agency regulations (40 CFR Part 15 and 61). This clause shall be added to any subcontracts.
 - l) Provide documentation of public notices for demolition activities.

ATTACHMENT B

Risk Assessment Conditions

Per Article VI of this contract, NDDDES is required to complete a Financial Assistance Risk Assessment rating form for every subgrantee receiving an award to evaluate their potential risk of non-compliance. Subgrantees will be evaluated on factors such as their prior experience with the same or similar subawards, results of previous audits including whether or not they received a Single Audit and the extent to which the same or similar subaward has been audited as a major program; if they have new personnel or new or substantially changed systems, and the extent and results of Federal awarding agency monitoring. Results of the Risk Assessment may result in the imposition of specific conditions, as allowed in 2 CFR § 200.207, and contained within this attachment..

Based upon the Risk Assessment completed for DR-4888-ND, City of Valley City has been determined to be Low Risk based upon the above mentioned criteria.

The specific conditions for a subgrantee determined to be Low Risk are the following:

- Subgrantees identified as Low Risk have no further conditions and may continue with their projects as approved by FEMA. This must include the completion of all project specific conditions, to include environmental requirements and/or permitting, placed upon individual projects by FEMA at the time of award or amendment. **Subgrantees that fail to comply with project specific conditions could potentially jeopardize their current and future federal funding.**

Every January, or as needed, NDDDES will re-evaluate all subrecipient Risk Assessments. Based on overall compliance with project requirements and any issues noticed therein, an updated Financial Assistance Recipient Risk Assessment will be completed and subrecipients can be upgraded or removed from low, medium or high risk status. If a subrecipient is non-compliant with the additional requirements of a subaward due to being considered high risk, the subaward and all federal and state monies can be deobligated at the request of NDDDES. Upon deobligation due to non-compliance, a subrecipient will be considered high risk in perpetuity.

ATTACHMENT C
Certification Regarding
Debarment, Suspension, Ineligibility
and
Voluntary Exclusion

Subcontractor Covered Transactions:

1. The prospective subcontractor of the Subgrantee certifies, by submission of this document, that neither it nor its principals is presently debarred, suspended, proposed for debarment, declared ineligible, or voluntarily excluded from participation in this transaction by any federal department or agency.
2. Where the Subgrantee's subcontractor is unable to certify to the above statement, the prospective subcontractor shall attach an explanation to this form.

SUBCONTRACTOR:

Name of Company

Street Address

City, State, Zip

Federal Employer Identification Number (FEIN)

By: _____
Signature Date

Subgrantee's Name

Grantee Agreement Number

Task Order: 2026 Pavement Improvements – Mill & Overlay, Pavement Rehabilitation and Seal Coat

In accordance with Paragraph 1.01 of the Agreement Between Owner and Engineer for Professional Services – Task Order Edition, dated January 1, 2021 ("Agreement"), Owner and Engineer agree as follows:

1. Background Data

- a. Effective Date of Task Order: December 2, 2025
- b. Owner: City of Valley City
- c. Engineer: KLJ Engineering LLC
- d. Specific Project (title): 2026 Pavement Improvements
- e. Specific Project (description): Valley View – Mill & Overlay and Incidentals
Granger’s Addition – Pavement Rehabilitation and Incidentals
Various Locations – Seal Coat and Incidentals

2. Services of Engineer

- A. The specific services to be provided or furnished by Engineer under this Task Order are:
set forth in Exhibit A, Engineer’s Services, and attached to and incorporated as part of this Task Order.
- B. Resident Project Representative (RPR) Services – Not Used
- C. Designing to a Construction Cost Limit – Not Used
- D. Other Services – Not Used
- E. All of the services included above comprise Basic Services for purposes of Engineer’s compensation under this Task Order.

3. Additional Services

- A. Additional Services that may be authorized or necessary under this Task Order are: Not Used

4. Owner's Responsibilities

Owner shall have those responsibilities set forth in Article 2 of the Agreement and in Exhibit B.

5. Task Order Schedule

In addition to any schedule provisions provided in Exhibit A or elsewhere, the parties shall meet the following schedule: Work to be completed by February 28, 2026.

6. Payments to Engineer

A. Owner shall pay Engineer for services rendered under this Task Order as follows:

Description of Service	Amount	Basis of Compensation
1. Basic Services		
a. Preliminary Engineering		Hourly
i. Project Management, Special Assessments and Public Involvement	\$9,500.00	
ii. Preliminary Engineering and Survey	\$17,000.00	
b. Design Engineering		Hourly
i. Preliminary Plans/Plan Review	\$35,500.00	
ii. Final Plans – Revisions and Submittal	\$23,000.00	
iii. Bidding Documents & Bid Opening	\$7,500.00	
TOTAL COMPENSATION (lines 1.a-b)	\$92,500.00	
2. Additional Services	(N/A)	

Compensation items and totals based in whole or in part on Hourly Rates or Direct Labor are estimates only. Estimated totals included in the breakdown by phases incorporate Engineer’s labor, overhead, profit, reimbursable expenses (if any), and Consultants’ charges, if any. Engineer shall not exceed the total compensation amount unless approved in writing by the Owner.

B. The terms of payment are set forth in Article 4 of the Agreement and in the applicable governing provisions of Exhibit C.

7. Consultants retained as of the Effective Date of the Task Order: None

8. Other Modifications to Agreement and Exhibits: None

9. Attachments:

Exhibit A – Engineer’s Services – Preliminary & Design Engineering

10. Other Documents Incorporated by Reference:

January 1, 2021 Agreement between Owner and Engineer for Professional Services

11. Terms and Conditions

Execution of this Task Order by Owner and Engineer shall make it subject to the terms and conditions of the Agreement (as modified above), which Agreement is incorporated by this reference. Engineer is authorized to begin performance upon its receipt of a copy of this Task Order signed by Owner.

OWNER: City of Valley City

ENGINEER: KLJ Engineering LLC

By: _____

By: _____

Print Name: Dave Carlsrud

Print Name: _____

Title: Mayor

Title: _____

Firm's Certificate No. (if required): 061-C

State of: North Dakota

Witness:

Witness:

By: _____

By: _____

Print Name: Brenda Klein

Print Name: _____

Title: Finance Director

Title: _____

DESIGNATED REPRESENTATIVE FOR TASK ORDER:

DESIGNATED REPRESENTATIVE FOR TASK ORDER:

Name: Gwen Crawford

Name: Chad Petersen

Title: City Administrator

Title: Senior Project Manager

Address: 220 3rd St NE
Valley City, ND 58072

Address: 1010 4th Ave SW
Valley City, ND 58072

E-Mail: gcrawford@valleycity.us

E-Mail: chad.petersen@kljeng.com

Phone: (701)845-8120

Phone: (701)845-9446

Task Order Form

**EJCDC® E-505, Agreement Between Owner and Engineer for Professional Services – Task Order Edition.
Copyright © 2014 National Society of Professional Engineers, American Council of Engineering Companies,
and American Society of Civil Engineers. All rights reserved.**



**EXHIBIT A
SCOPE OF SERVICES
PRELIMINARY & DESIGN ENGINEERING**

November 25, 2025

KLJ Engineering, LLC

2026 Pavement Improvements

**Valley View - Mill & Overlay and Incidentals
Granger's Addition - Pavement Rehabilitation and Incidentals
Various Locations - Seal Coat and Incidentals**

PURPOSE

The purpose of this exhibit is to describe the scope of work and responsibilities required to complete Preliminary and Design Engineering services for the proposed project. KLJ Engineering, LLC (KLJ) will provide Project Management, Survey, Preliminary and Design Engineering for the proposed project.

OBJECTIVE

The objective of the preliminary phase is to perform field survey and preliminary engineering. The objective of the design phase is to develop plans and specifications for bidding, including opinion of cost. The project will include Mill & Overlay, Pavement Rehabilitation, Seal Coat and Incidentals.

PROJECT MANAGEMENT & COORDINATION

Project Management

KLJ will manage and coordinate the work completed by the KLJ project team. This work will consist of managing work assignments, internal team meetings, client and agency coordination, project budget, and project schedule. KLJ will also implement a QC/QA plan for the preliminary and design phase which will be documented and overseen by the project manager.

Special Assessment Process

KLJ will assist the City with the Special Assessment process. This work will include preparing the Preliminary Engineering Report, assisting with the Benefit Analysis and attending the Public Informational Meeting.

PRELIMINARY ENGINEERING

Field Survey

KLJ will conduct a field survey for the entire project corridors, collecting the necessary information to design the project. KLJ will download the survey information for use in the design phase of the project.

ENGINEERING, REIMAGINED



DESIGN ENGINEERING

Preliminary Plans/Plan Review

KLJ will perform design calculations and develop all necessary plan sheets. KLJ will distribute one review copy of the preliminary plans at approximately 90% completion and conduct a plan review with the City of Valley City.

It is anticipated that the preliminary plans will include the following plan sections:

- Section 1 Title Sheet
- Section 2 Table of Contents/Standard Drawings
- Section 4 Scope of Work
- Section 6 Plan Notes
- Section 8 Estimate of Quantities
- Section 10 Basis of Estimate
- Section 30 Typical Sections
- Section 40 Removals
- Section 90 Pavement Layouts

Final Plans – Revision and Submittal

Revisions from the Plan Review will be incorporated into the final plans. KLJ will complete and document a final internal QA review.

KLJ will submit one copy of the final plans to the City of Valley City.

Opinion of Cost

KLJ will create the Opinion of Cost at 90% Plans and Final Plans.

Bidding Documents & Bid Opening

KLJ will develop bid documents and specifications for the project. Plans, specifications, and bidding documents will be posted to Quest for advertisement for bid.

KLJ will be available to answer pre-bid questions from the contractors and assist in preparation of bid documents. KLJ will be prepare up to two addenda, if necessary. KLJ will review the bid results and provide a recommendation to award the project.

Deliverable Provided by KLJ

- Preliminary Plans and Preliminary Opinion of Costs
- Final Plans and Opinion of Costs
- Bidding Documents

Work Not Included in This Scope of Work

- NDDOT Coordination
- Aquatic Resource Delineation
- Cultural Resource Survey
- NEPA documentation
- Right of Way acquisition
- Construction Engineering

ENGINEERING, REIMAGINED

PROPOSED 2026 MILL & OVERLAY, REHABILITATION AND SEAL COAT PROJECT CITY OF VALLEY CITY, NORTH DAKOTA

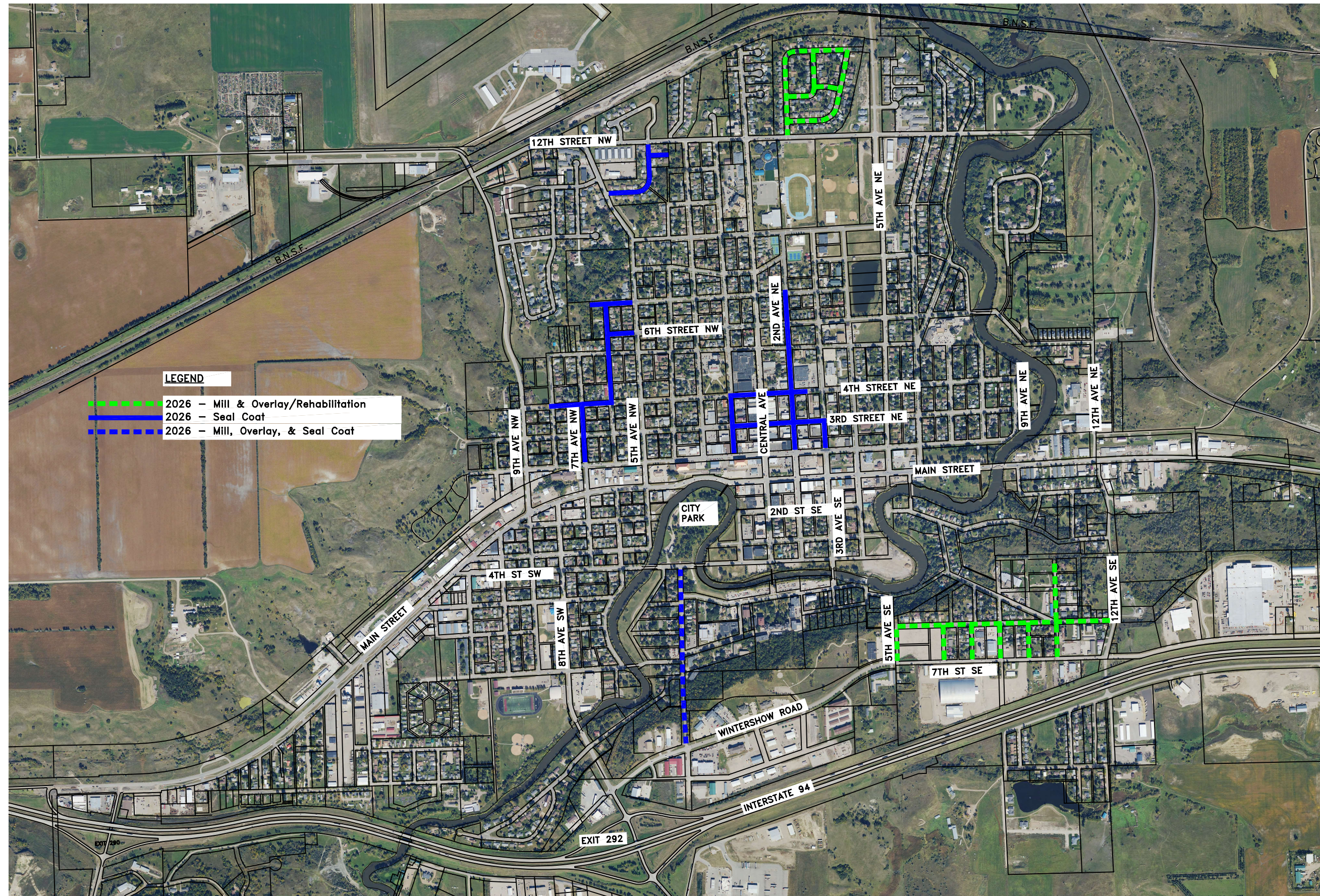

This Agreement is between the State of North Dakota acting by and through its Industrial Commission (Commission) and City of Valley City (Contractor). The effective date of this Agreement is November 26, 2024.

1. Independent Contractor

Contractor will be responsible for any federal or state taxes applicable to this grant made under this Agreement. Contractor is an independent entity and is not a State employee or employee of the Industrial Commission for any purpose, including the application of the Social Security Act, the Fair Labor Standards Act, the Federal Insurance Contribution Act, the North Dakota Unemployment Compensation Law, the North Dakota Workforce Safety and Insurance Act and the Public Employees' Retirement System.

2. Scope of Work

a. The Contractor agrees to perform the work described in Exhibit A, entitled "Transmission Line" (the "Work"), which is attached to this Agreement and made part of it.

b. The Contractor agrees to provide reports (the "Reports") for the Work as follows:

Status Report 1:	January 1, 2026
Status Report 2:	April 1, 2026
Status Report 3:	July 1, 2026
Status Report 4:	October 1, 2026
Status Report 5:	January 1, 2027
Status Report 6:	April 1, 2027
Status Report 7:	July 1, 2027
Final Report:	October 1, 2027

Each Report must provide documentation on expenditures and verification of the receipt and expenditure of the match funding.

Data and the Reports shall be provided to the Commission in an electronic format without restrictions. The electronic version must be in a suitable format for hosting on the Industrial Commission website.

In addition, the Reports will contain information developed within the Work phases, as described in Exhibit A, including summaries of:

- Report documenting progress of bid packet and advertisement
- Report on ordering of materials
- Reports documenting installation of transmission line
- Reports documenting completion of final inspection
- Reports on any deviations from original scope of work, rationale for such deviations, and any lessons learned
- Any other deliverables included in Exhibit A

3. Consideration

a. For performing the Work, the Commission agrees to pay the Contractor an amount not to exceed \$715,468 according to the following schedule:

Upon receipt of documentation showing expenditure of funds for work completed, receipt of match funding and consideration of the Reports, with disbursements to be no more frequent than the schedule in Section 2b	\$643,921
Upon receipt of documentation of expenditures and consideration	\$71,547

of final report	
-----------------	--

- b. If after reviewing the Reports, the Commission believes that the Reports are inadequate or that the Contractor is not complying with the scope of Work or satisfactorily carrying out the Work for any reason in the Commission's sole discretion, the Commission may withhold all or part of a scheduled payment until the Contractor, in the Commission's sole discretion, has remedied any deficiency.

4. Authority to Contract and Subcontract

The Contractor does not have the authority to contract for or incur obligations on behalf of the Commission.

The Contractor may not assign or otherwise transfer or delegate any right or duty related to this Agreement without the Commission's written consent.

After written approval by the Commission, the Contractor may, however, enter into subcontracts provided that any subcontract acknowledges the binding nature of this Agreement and incorporates this Agreement including any non-confidential and applicable attachments, into the subcontract.

The Contractor is solely responsible for the performance of any Subcontractor with whom the Contractor contracts. Contractor does not have authority to contract for or incur obligations on behalf of Commission.

5. Funds Available and Authorized

The Commission certifies at the time of the execution of the Agreement sufficient funds are available and authorized for expenditure to finance costs of this Agreement within the Commission's current appropriation or limitation to June 30, 2027. The Commission by written notice to the Contractor, may terminate the whole or any part of this Agreement under any of the following conditions:

- a. If funding from federal, state, or other sources is not obtained and continued at levels sufficient to allow for the payment for the Work or the purchase of the services or supplies in the indicated quantities or term.
- b. If federal or state laws or rules are modified or interpreted in a way that the services are no longer allowable or appropriate for purchase under this Agreement or are no longer eligible for the funding proposed for payments authorized by this Agreement.
- c. If any license, permit, or certificate required by law or rule, or by the terms of this Agreement, is for any reason denied, revoked, suspended, or not renewed.

Termination of this Agreement under this subsection is without prejudice to any obligations or liabilities of either party already accrued prior to termination.

6. Termination

This Agreement may be terminated by the Commission upon thirty (30) days' written notice to Contractor. This Agreement may be terminated by mutual written consent of both parties.

The Commission may unilaterally terminate this Agreement effective upon delivery of written notice to the Contractor, or any later date stated in this notice, if:

- a. The Contractor fails to provide services required by the Agreement and the Work described in Exhibit A within the time specified or any extension agreed to by the Commission; or

- b. The Contractor fails to perform any of the other provisions of this Agreement, or so fails to pursue the Work as to endanger performance of this Agreement in accordance with its terms.

The rights and remedies of the Commission provided in Section 6 are not exclusive but are in addition to any other rights and remedies provided by law or under this Agreement. Any such termination of this Agreement, other than those identified under Section 6(a) or (b), shall be without prejudice to any obligations or liabilities of either party already accrued prior to such termination. Further, in the event of termination under Section 6, it is understood that no further funding will be provided to the Contractor.

If the Commission terminates this Agreement for any reason including default of any term or obligation by the Contractor, the Contractor shall immediately reimburse the Commission the amount of all money paid by the Commission to the Contractor hereunder.

7. Agreement Management

Notwithstanding the Contractor's responsibility for total management of the Work, the administration of the Agreement will require coordination between the Commission and the Contractor.

Commission's Authorized Officer

The Commission's Authorized Officer will carry out all contractual administration of this Agreement. Communications pertaining to this Agreement must be addressed to:

North Dakota Industrial Commission
Attention: Grant Program Administrator
State Capitol 14th Floor
600 E Boulevard Ave Dept 405
Bismarck, North Dakota 58505-0840
ndicgrants@nd.gov

The Commission's Authorized Officer is the only person, other than the Commission, authorized to approve changes in any of the requirements under this Agreement.

8. Access to Records

The Commission, the State Auditor of the State of North Dakota, and the Office of the Attorney General of the State of North Dakota, and their duly authorized representatives, shall have access to the books, documents, papers and records of the Contractor which are directly pertinent to this Agreement as determined by the Commission in its sole discretion for the purpose of making audit, examination, excerpts and transcripts.

It is noted that if the documentation for the expenditures related to this Agreement including the in-kind contributions and match funding are not delivered to the Commission for the Commission's files, the Contractor hereby agrees that the documentation will be maintained in the Contractor's offices for four (4) years from the completion date of the Work and the Contractor will provide access to the documentation if so requested.

9. Confidentiality

Contractor shall not use or disclose any information it receives from Commission under this Agreement that Commission has previously identified as confidential or exempt from mandatory public disclosure except as necessary to carry out the purposes of this Agreement or as authorized in advance by Commission. Commission shall not disclose any information it receives from Contractor that Contractor has previously identified as confidential and that Commission determines in its sole discretion is protected from mandatory public disclosure under a specific exception to the North Dakota public records law, N.D.C.C. ch. 44-04. The duty of Commission and Contractor to maintain

confidentiality of information under this section continues beyond the completion of this Agreement.

10. Indemnity and Insurance

The Contractor agrees to defend, indemnify, and hold harmless the state of North Dakota, its agencies, officers and employees (State), from and against claims based on the vicarious liability of the State or its agents, but not against claims based on the State's contributory negligence, comparative and/or contributory negligence or fault, sole negligence, or intentional misconduct. This obligation to defend, indemnify, and hold harmless does not extend to professional liability claims arising from professional errors and omissions. The legal defense provided by the Contractor to the State under this provision must be free of any conflicts of interest, even if retention of separate legal counsel for the State is necessary. Any attorney appointed to represent the State must first qualify as and be appointed by the North Dakota Attorney General as a Special Assistant Attorney General as required under N.D.C.C. § 54-12-08. The Contractor also agrees to reimburse the State for all costs, expenses and attorneys' fees incurred if the State prevails in an action against the Contractor in establishing and litigating the indemnification coverage provided herein. This obligation shall continue after the termination of this agreement.

The Contractor shall secure and keep in force during the term of this agreement and shall require all subcontractors, prior to commencement of an agreement between the Contractor and the subcontractor, to secure and keep in force during the term of this agreement, from insurance companies, government self-insurance pools or government self-retention funds, authorized to do business in North Dakota, the following insurance coverages:

- a. Commercial general liability, including premises or operations, contractual, and products or completed operations coverages (if applicable), with minimum liability limits of \$2,000,000 per occurrence.
- b. Automobile liability, including Owned (if any), Hired, and Non-Owned automobiles, with minimum liability limits of \$500,000 per person and \$2,000,000 per occurrence.
- c. Workers compensation coverage meeting all statutory requirements. The policy shall provide coverage for all states of operation that apply to the performance of this contract.
- d. Employer's liability or "stop gap" insurance of not less than \$2,000,000 as an endorsement on the workers compensation or commercial general liability insurance.
- e. Professional errors and omissions with minimum limits of \$2,000,000 per claim and in the aggregate, the Contractor shall continuously maintain such coverage during the contact period and for three years thereafter. In the event of a change or cancellation of coverage, the Contractor shall purchase an extended reporting period to meet the time periods required in this section.

The insurance coverages listed above must meet the following additional requirements:

- a. Any deductible or self-insured retention amount or other similar obligation under the policies shall be the sole responsibility of the Contractor. The amount of any deductible or self-retention is subject to approval by the State.
- b. This insurance may be in policy or policies of insurance, primary and excess, including the so-called umbrella or catastrophe form and must be placed with insurers rated "A-" or better by A.M. Best Company, Inc., provided any excess policy follows form for coverage. Less than an "A-" rating must be approved by the State. The policies shall be in form and terms approved by the State.
- c. The duty to defend, indemnify, and hold harmless the State under this agreement shall not be limited by the insurance required in this agreement.
- d. The state of North Dakota and its agencies, officers, and employees (State) shall be endorsed on the commercial general liability policy on a primary and noncontributory basis, including any excess policies (to the extent applicable), as additional insured.

The State shall have all the benefits, rights and coverages of an additional insured under these policies that shall not be limited to the minimum limits of insurance required by this agreement or by the contractual indemnity obligations of the Contractor.

- e. A "Waiver of Subrogation" waiving any right to recovery the insurance company may have against the State.
- f. The Contractor shall furnish a certificate of insurance to the undersigned State representative prior to commencement of this agreement. All endorsements shall be provided as soon as practicable.
- g. Failure to provide insurance as required in this agreement is a material breach of contract entitling the State to terminate this agreement immediately.
- h. Contractor shall provide at least 30-day notice of any cancellation or material change to the policies or endorsements. Contractor shall provide on an ongoing basis, current certificates of insurance during the term of the contract. A renewal certificate will be provided 10 days prior to coverage expiration. An updated, current certificate of insurance shall be provided in the event of any change to a policy.

11. Nondiscrimination – Compliance with Laws

The Contractor shall comply with all federal, state and local laws and ordinances applicable to the work to be done under this Agreement. Further, Contractor agrees to comply with all laws, rules and policies, including those relating to nondiscrimination, accessibility and civil rights. The Contractor agrees to timely file all required reports, make required payroll deductions, and timely pay all taxes and premiums owed, including sales and use taxes, unemployment compensation and workers' compensation premiums. The Contractor shall have and keep current at all times during the term of this Agreement all licenses and permits required by law. The Contractor's failure to comply with this section may be deemed a material breach by the Contractor entitling the Commission to terminate in accordance with the Termination section of this Agreement.

12. Applicable Law and Venue

This Agreement shall be governed by and construed in accordance with the laws of the State of North Dakota. Any action to enforce this Agreement must be adjudicated exclusively in the state District Court of Burleigh County, North Dakota. Each party consents to the exclusive jurisdiction of such court and waives any claim for lack of jurisdiction or *forum non conveniens*.

13. Notices

All notices or other communications required under this Agreement must be given by registered or certified mail and are complete on the date postmarked when addressed to the parties at the following addresses:

Industrial Commission of North Dakota
State Capitol 14th Floor
600 E Boulevard Ave Dept 405
Bismarck, ND 58505-0840

Valley City Public Works
254 2nd Ave NE
Valley City, ND 58072

Notice provided under this provision does not meet the notice requirements for monetary claims against the State found at N.D.C.C. § 32-12.2-04.

14. Assignment; Successors in Interest

The Contractor may not assign or otherwise transfer or delegate any right or duty without Commission's express written consent, provided, however, that the Contractor may assign its rights and obligations hereunder in the event of a change of control or sale of all or substantially all of its assets related to this Agreement, whether by merger, reorganization, operation of law, or otherwise.

Should assignee be a business or entity with whom the Commission is prohibited from conducting business, the Commission shall have the right to terminate without cause.

The provisions of this Agreement shall be binding upon and shall inure to the benefit of the parties hereto, and their respective successors and assigns.

15. Attorney Fees

In the event a lawsuit is initiated by the Commission to obtain performance due under this Agreement, and the Commission is the prevailing party, the Contractor shall, except when prohibited by N.D.C.C. § 28-26-04, pay Commission's reasonable attorney fees and costs in connection with the lawsuit.

16. Severability

The parties agree that if any term or provision of this Agreement is declared by a court of competent jurisdiction to be illegal or unenforceable, the validity of the remaining terms and provisions is unaffected, and, if possible, the rights and obligations of the parties shall be construed and enforced as if the Agreement did not contain the particular term or provision held to be invalid.

17. Waiver; Amendments

The failure of the Commission to enforce any provisions of this Agreement shall not constitute a waiver by the Commission of that or any other provision. The terms of this Agreement shall not be waived, altered, modified, supplemented, or amended, in any manner whatsoever, except by written instrument signed by the parties.

18. Merger Clause

This Agreement, including any incorporated attachments, constitutes the entire agreement between the parties. No waiver, consent, modification or change of terms of this Agreement shall bind either party unless in writing and signed by both parties. Such waiver, consent, modification or change, if made, shall be effective only in the specific instance and for the specific purpose given. There are no understandings, agreements, or representations, oral or written, not specified herein regarding this Agreement. The Contractor, by the signature below of its authorized representative, hereby acknowledges that the Contractor has read this Agreement, understands it, and agrees to be bound by its terms and conditions.

19. Captions

The captions or headings in this Agreement are for convenience only and in no way define, limit, or describe the scope or intent of any provisions of this Agreement.

20. Legal Notice/Disclaimer

The following notice shall be contained in all reports intended to be released to the public:

This report was prepared by City of Valley City/Valley City Public Works pursuant to an agreement with the Industrial Commission of North Dakota, which was partially funded through the IIJA Grid Resilience Program.

City of Valley City/Valley City Public Works, or any of its subcontractors, and the Industrial Commission of North Dakota, or any person acting on its behalf, do not:

(A) Make any warranty or representation, express or implied, with respect to the accuracy, completeness, or usefulness of the information contained in this report, or that the use of any information, apparatus, method, or process disclosed in this report may not infringe privately-owned rights; or

(B) Assume any liabilities with respect to the use of, or for damages resulting from the use of, any information, apparatus, method or process disclosed in this report.

Reference herein to any specific commercial product, process, or service by trade name, trademark, manufacturer, or otherwise, does not necessarily constitute or imply its endorsement, recommendation, or favoring by the Industrial Commission of North Dakota. The views and opinions of authors expressed herein do not necessarily state or reflect those of the Industrial Commission of North Dakota.

22. Compliance with Public Records Law

Under the North Dakota public records law and subject to the Confidentiality clause of this Contract, certain records may be open to the public upon request.

Public records may include: (a) records Commission receives from CONTRACTOR under this Contract, (b) records obtained by either Party under this Contract, and (c) records generated by either Party under this Contract.

Contractor agrees to contact Commission immediately upon receiving a request for information under the public records law and to comply with Commission's instructions on how to respond to such request.

23. Execution and Counterparts

This Agreement may be executed in several counterparts, each of which shall be an original, all of which shall constitute but one and the same instrument.

24. U.S. Department of Energy Special Terms and Conditions

Contractor agrees to the U.S. Department of Energy Special Terms and Conditions in Exhibit B, which is attached to this agreement and made a part of it.

25. Time is of the Essence

CONTRACTOR hereby acknowledges that time is of the essence for performance under this Contract unless otherwise agreed to in writing by the Parties.

26. Force Majeure

Neither Party shall be held responsible for delay or default caused by fire, riot, terrorism, pandemic (excluding COVID-19), acts of God, or war if the event was not foreseeable through the exercise of reasonable diligence by the affected Party, the event is beyond the Party's reasonable control, and the affected Party gives notice to the other Party promptly upon occurrence of the event causing the delay or default or that is reasonably expected to cause a delay or default. If CONTRACTOR is the affected Party and does not resume performance within fifteen (15) days or another period agreed between the Parties, then COMMISSION may seek all available remedies, up to and including termination of this Contract pursuant to its Termination Section, and COMMISSION shall be entitled to a pro-rata refund of any amounts paid for which the full value has not been realized, including amounts paid toward software subscriptions, maintenance, or licenses.

27. Works for Hire

CONTRACTOR acknowledges that all work(s) under this Contract is "work(s) for hire" within the meaning of the United States Copyright Act (Title 17 United States Code) and hereby assigns to STATE all rights and interests CONTRACTOR may have in the work(s) it prepares under this Contract, including any right to derivative use of the work(s). All software and related materials developed by CONTRACTOR in performance of this Contract for STATE shall be the sole property of STATE, and CONTRACTOR hereby assigns and transfers all its right, title, and interest therein to STATE. CONTRACTOR shall execute all necessary documents to enable STATE to protect STATE's intellectual property rights under this section.

Work Product

All work product, equipment or materials created for STATE or purchased by STATE under this Contract belong to STATE and must be immediately delivered to STATE at STATE's request upon termination of this Contract.

28. Spoliation (Notice Of Potential Claims)

CONTRACTOR shall promptly notify Commission of all potential claims that arise or result from this Contract. CONTRACTOR shall also take all reasonable steps to preserve all physical evidence and information that may be relevant to the circumstances surrounding a potential claim, while maintaining public safety, and grants to STATE the opportunity to review and inspect such evidence, including the scene of the accident.

29. Alternative Dispute Resolution – Jury Trial

By entering this Contract, Commission does not agree to binding arbitration, mediation, or any other form of mandatory Alternative Dispute Resolution. The Parties may enforce the rights and remedies in judicial proceedings. Commission does not waive any right to a jury trial.

30. State Audit

Pursuant to N.D.C.C. § 54-10-19, all records, regardless of physical form, and the accounting practices and procedures of CONTRACTOR relevant to this Contract are subject to examination by the North Dakota State Auditor, the Auditor's designee, or Federal auditors, if required. CONTRACTOR shall maintain these records for at least three (3) years following completion of this Contract and be able to provide them upon reasonable notice. State, State Auditor, or Auditor's designee shall provide reasonable notice to CONTRACTOR prior to conducting examination.

CITY OF VALLEY CITY/VALLEY CITY PUBLIC WORKS

NORTH DAKOTA INDUSTRIAL COMMISSION

By: _____
Name

By: _____
Jordan Kannianen
Deputy Executive Director

Title

Date: _____

Date: _____